

G2C Series

*Vertical, Cantilevered Pump
For Flows to 2,500 GPM*



 **Carver[®]**

Creating Value.

The G2C Series

The G2C Series is Carver's newest version of vertical pumps for handling fluids at moderate to high flow rates. This design is a cantilever style unit that features non-wetted radial and thrust bearings located above the support plate, with a throttle bushing located immediately above the impeller.

The G2C is based on the same product platform as our vertical sump and horizontal end suction pumps. Hydraulic performance extends to 2,500 GPM at 1,750 RPM and is covered by 23 sizes in cast iron, 316 SS fitted, and all 316 SS construction as standard. Other materials, including Alloy 20 and Hastelloy B & C, are available for more corrosive applications as well. For simplicity, there are only two sizes of bearing frame/motor mounting brackets between the 23 sizes of units. The bearing frame/motor mounting brackets are a one-piece design to insure rigidity and alignment integrity.

As a standard, these units are typically offered in two column depths. The standard column setting has a 12 inch distance between the bottom of the mounting plate and back of the pump casing.

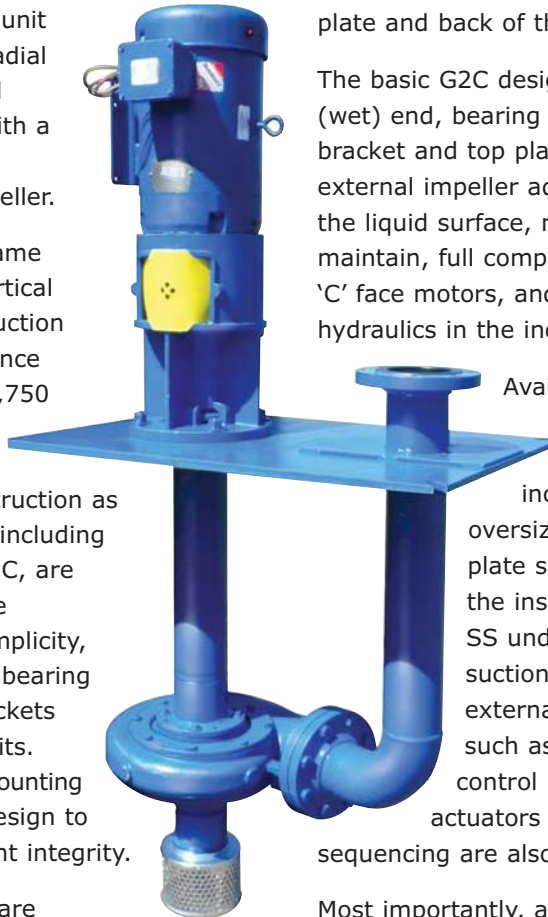

The extended column setting, on the other hand, is twice this length, giving a 24 inch distance between the bottom of the mounting plate and back of the pump casing.

The basic G2C design consists of a pumping (wet) end, bearing frame/motor mounting bracket and top plate. All models feature external impeller adjustment, bearings above the liquid surface, no mechanical seals to maintain, full compatibility with standard NEMA 'C' face motors, and some of the most efficient hydraulics in the industry.

Available as an option, discharge piping with Class 150 lb. flange dimensions can be included (either standard or oversized) on an enlarged support plate should it be a requirement of the installation. Additionally, 316 SS underliners for support plates, suction strainers, inlet tail pipes, external flush lines, and accessories such as automatic greasers and control panels with float switch actuators for automatic start/stop sequencing are also available.

Most importantly, as with all our other pumps, the G2C offers the reliability, low total life cost, and lasting value that has made Carver one of the most trusted names in pumps.

Hydraulics

- Flows to 2,500 US GPM (570 m³/hr)
- Efficiencies to 85%
- Solids to 1.625" diameter (41 mm)
- Power to 75 HP (56 KW)
- Speeds to 3,500 RPM

Applications

- Acids and solvents transfer
- E-coat systems
- Fluid filtering
- Drain sump transfer
- Lubrication for rotating equipment
- Machine coolant recovery
- Spray paint systems
- Parts washer circulation
- Ultra high purity water wash systems
- Various other proprietary systems



Features & Benefits



Available less discharge pipe.

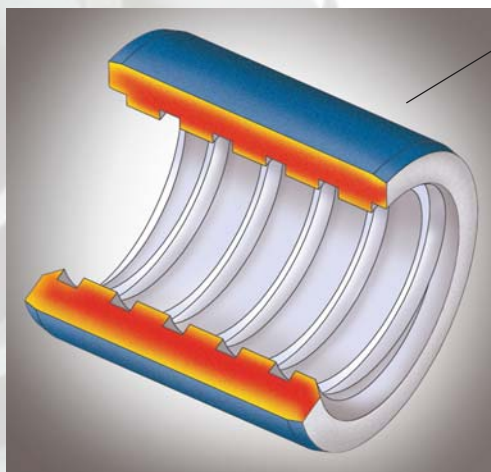

Motors

Operation with standard, easily available NEMA 'C' face motors

Ball Bearings

Oversized, grease lubricated ball bearings located above tank top for easy maintenance

Shafts

Solid, one piece shafts are designed with optimum diameter and bearing span for minimal deflection

Throttle Bushing

Spiral grooved Teflon or hardened 17-4 PH stainless steel with optional shaft sleeves for longer life when pumping dirty or abrasive fluids

Impellers

High efficiency design – individually balanced to stringent ISO G2.5 standards for low vibration resulting in smoother operation, maximizing overall pump life

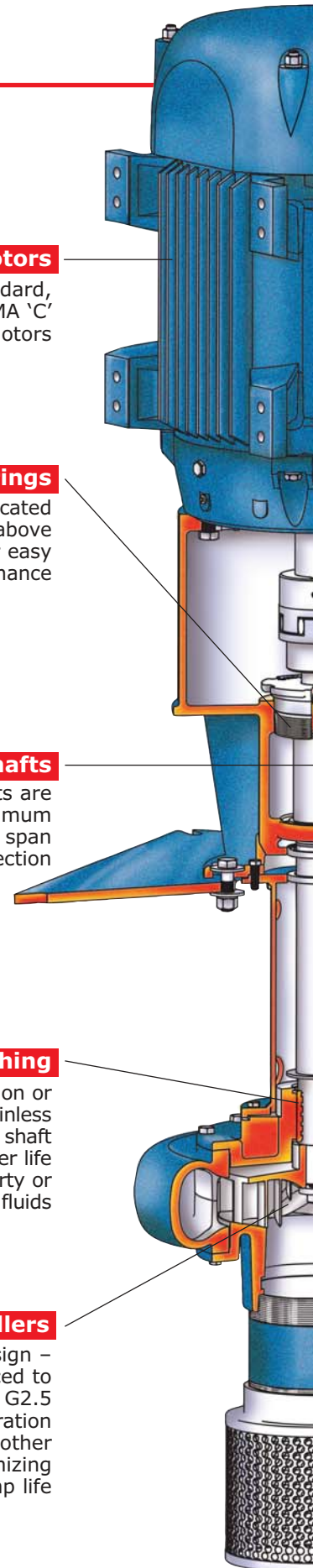

Bearing Frame/Motor Mounting Bracket

Heavy duty, one piece, thick-walled cast iron frame/bracket supports bearings above the tank surface, protecting them from fluid and vapors, while providing accurate alignment between pump and motor shaft which results in increased bearing life

Impeller Adjustment

External adjusting wheel allows precise in-place adjustment of impeller-to-casing clearance, optimizing hydraulic performance over the life of the pump

Discharge Connections

Raised face flanges featuring Class 150 lb. flange dimensions provide positive connections and ease of installation

Suction Connections

FNPT connections allow easy addition of tailpipe extensions and/or suction strainers

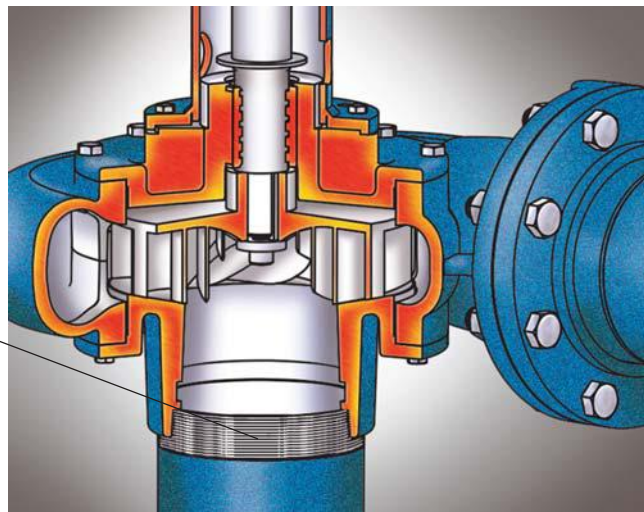
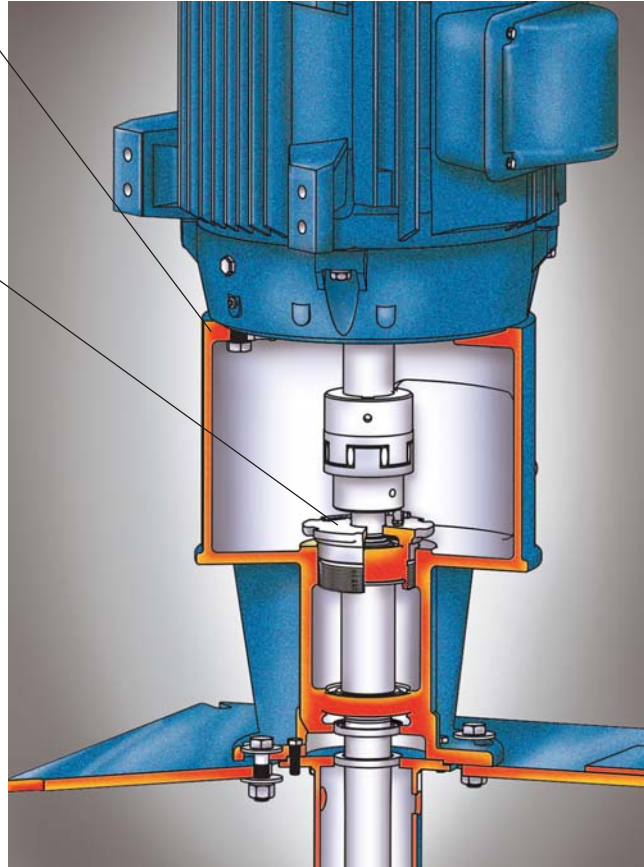

Hydraulic Coverage @ 1750 RPM

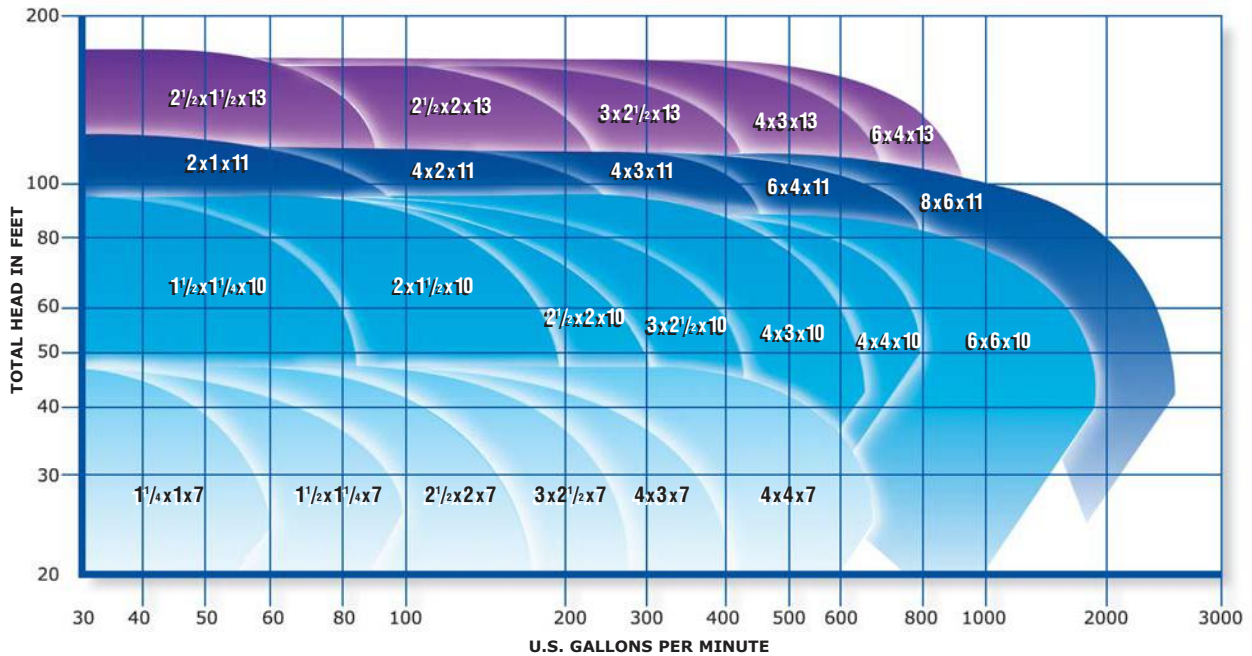

Why A G2C?

Along with all of its technical advantages, the G2C also offers the indirect benefits of:

- robust designs with the same reliability and quality that we have been providing the United States military for the past 75 years
- extensive standard and optional features that assure total flexibility in meeting system installation and hydraulic performance requirements
- backing by over 70 stocking distributors, sales agents, and certified service centers – the largest aftermarket support group for pumps of this type in the world.

There are many things to consider when selecting a vertical pump. However, in the end it all comes down to value, and the G2C delivers more of it than any other pump.

To see for yourself, contact us or any of our stocking distributors.

Standard Materials

Casing	Cast iron or 316 SS
Impeller	Cast iron or 316 SS
Piping	Carbon steel or 316 SS
Throttle Bushing	Teflon or 17-4 PH SS
Top Plate	Carbon steel or 316 SS
Shaft	Carbon steel or 316 SS
Shaft Sleeve	416 SS

Mechanical Data

Rotation	CW as standard
Input Power	Up to 75 HP
Discharge Connection	Class 150 lb. flange
Bearing Lubricant	Grease as standard
Radial Bearing L ₁₀ Life	50,000 hours
Thrust Bearing L ₁₀ Life	25,000 hours



Approval Certification Number 95-370H



Since we built our first pumps in 1938, the Carver name has become synonymous with value. Today we are recognized as one of the world's leading centrifugal pump companies, building pumps to the most demanding engineering specifications and military standards in the world.

Our company is located in Muscatine, Iowa, 25 miles southwest of the Quad Cities area. Our operations there include some of the most modern manufacturing equipment and pump development software available, and we are committed to the highest quality possible in our products and our people. Along these lines, Carver was also one of the first American pump companies to attain ISO 9001 certification—the most recognized standard for quality in the world.

From an applications standpoint Carver has traditionally built pumps for water, oil, and chemicals for both the public and private sectors. Our product line includes both horizontal and vertical end suction, multi-stage, axial split case, self-priming, API, and solids-handling pumps that all carry the same Carver trademark: lasting value from solid, straightforward designs engineered to provide many years of service.

These pumps are also backed by unparalleled aftermarket support. Our network of stocking distributors, manufacturer's representatives and certified service centers throughout the world means that no matter where your pump may be installed, there are local sales and service people ready to support your aftermarket needs.



Carver Pump Company

2415 Park Avenue • Muscatine, IA 52761
563.263.3410 • Fax: 563.262.0510

www.carverpump.com

