



# Delta P Carver

We Put the PSI in Water Systems

- Low Operating Cost
- High Flow Rates  
Low Head
- Any Replacement  
or Retrofit
- 304 SS Frames  
& Manifolds
- Variable Speed  
Drives
- 3 Year Warranty
- 4 - 10 inch Choice  
for LCD Color  
Touch Screens



## Delta Pak – ES

**Domestic Water Booster Systems**

**Custom Engineered for Reliability & Efficiency**

[www.deltapcarver.com](http://www.deltapcarver.com)

[sales@deltapcarver.com](mailto:sales@deltapcarver.com)

Among its many advantages, the Delta Pak - ES offers the technical design features of:

- ▲ Single Point Power Main Disconnect
- ▲ Manual Motor Protector (MMP) 65KAIC
- ▲ VFD Controls with Programmable Set Points
- ▲ NSF 61/372 System Certification
- ▲ All Valves are NSF Certified
- ▲ Control Panel is UL 508A
- ▲ Individual VFD for Each Pump
- ▲ Low Voltage – 24V DC Touch Safe Controls
- ▲ PLC with Ethernet Capability, Building Communication (BACnet, LONWORKS and More)
- ▲ Simplex, Duplex, Triplex, and Quadraplex
- ▲ Thermo Relief Valve for Each Pump
- ▲ Max System Temperature 212° F
- ▲ Inlet and Outlet Connection Rolled Groove Flange (Welded Flange Optional, ANSI Class 150 or 300)
- ▲ 3 Year System Warranty

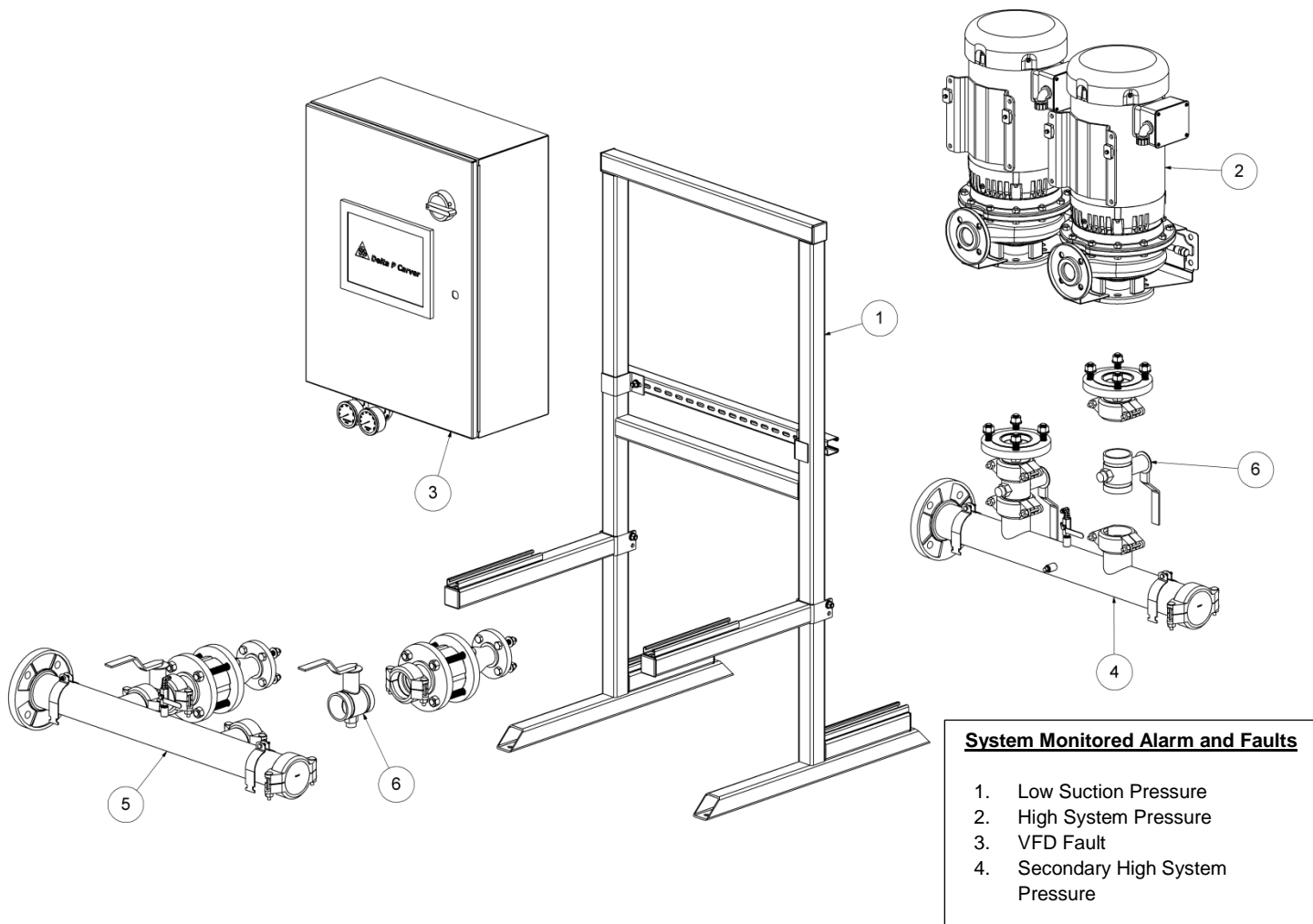

ITEM NO.	DESCRIPTION
1	Frame Assembly
2	Pump Assembly
3	Control Pak

ITEM NO.	DESCRIPTION
4	Manifold Assembly Suction (600 PSI)
5	Manifold Assembly Discharge (600 PSI)
6	Stainless Steel Internal Butterfly Isolation Valve (150/300 PSI)