

# Submersible Wastewater, Sewage Pump



Model DLFU  
Model DLFMU  
Model DLKFU  
Model DLKFMU

Operating Instructions, Installation & Maintenance Manual

---



**EBARA**

EBARA International Corporation, Fluid Handling Division



**Operating, Installation, and Maintenance**

**Contents**

<b>Section</b>	<b>Page</b>
Safety Information and Introduction.....	2
Specifications .....	2
Pump Checks .....	3
Installation .....	3
Operation .....	9
Maintenance and Service .....	10
Thermal Protector .....	17
Leakage Detector .....	18
Warranty .....	19

**Safety Information and Introduction**

**⚠ WARNING**

Before handling this pump, always disconnect the power first. Do not use sparkable electrical devices or flames in a septic (gaseous) or possible septic sump.

Do not work under heavy suspended object unless there is a positive support under it to stop its fall in event of sling or hoist failure. Disregard of this warning could result in personal injury.

This pump should only be serviced by qualified or factory trained personnel.

**⚠ CAUTION**

This instruction manual includes necessary items for installation, operation and maintenance. Read this manual carefully to ensure correct installation, operation and maintenance.

Be sure to keep this instruction manual on hand for future reference.

Design of this EBARA pump is based on superior engineering and long experience. To prevent trouble and provide satisfactory operation and long life, it is important to understand the EBARA pump thoroughly by careful study of this manual. If any questions arise regarding this manual, please direct them to EBARA INTERNATIONAL CORPORATION.

**Specifications**

**⚠ CAUTION**

Be careful not to exceed the given specifications in the use of your products.

Check the nameplate for your pump's head (HEAD), discharge volume (CAPACITY), speed (SPEED), motor voltage and current. Other specifications are noted in the chart below.

Item		Specifications
Liquid handled	Type	Sewage, waste water, miscellaneous drain water
	Temperature	32 - 104° F
Materials	Casing	Cast iron
	Impeller	Cast iron
	Shaft	Stainless Steel
Motor type		Air filled submersible motor
Shaft seal lubrication oil		Turbine No. 32 ISO VG - 32
Maximum water depth		65 ft
Installation		with Quick Discharge Connector or floor mounted



**Operating, Installation, and Maintenance****Pump Checks****1. Check the following points upon receipt of your pump:**

- (1) Check the name plate to confirm that it is the pump ordered.
- (2) Ensure that the pump voltage is the same as the power at your location.
- (3) Check oil level at oil plug.
- (4) Check that all plugs and fastening bolts are properly tightened.
- (5) Check that the pump has not been damaged and the cable glands and cables are in a satisfactory condition.
- (6) Check accessories and spare parts against the packing list.
- (7) Check that the impeller turns smoothly by hand.

**2. Precautions when operation is suspended:**

- (1) If operation is to be suspended for 30 days with the pump immersed in water, measure the insulation resistance of the motor.  
If resistance is over 1 mega ohm, operate pump to prevent rust from developing on moving parts. Follow the instructions under OPERATION when pump operation is to be resumed.
- (2) For dry storage, clean out pump and store in a dry place.  
Follow the instructions under INSTALLATION and OPERATION when pump operation is to be resumed.

**Installation****1. Check the following before beginning installation:****⚠ WARNING**

Before insulation resistance measurement, always disconnect the power first.

All electrical work should be performed by a qualified electrician and all national and local electrical codes must be observed.

**⚠ CAUTION**

When measuring the insulation resistance with meggar for motor windings do not test overload protection.

MINIATURE THERMAL PROTECTION (MTP) AND LEAKAGE DETECTOR (LD) ARE USED FOR MOTOR PROTECTION. MTP AND LD CABLES MUST BE INSTALLED IN CONTROL CIRCUIT.

Insulation resistance measurement:

**(1) For three phase motor:**

With the motor and cable (excluding the power supply connections) immersed in water, use a meggar to measure the insulation resistance between, the ground wire and each phase of the motor.

**⚠ CAUTION**

Measure the insulation resistance. The value should be more than 1 mega ohm. While making the measurement, keep the power supply cable off the ground.

**Installation**

**2. Pump Installation**

**WARNING**

When lifting the pump, use appropriate crane (or hoist) and lift system, check position and tightness of lift system so that weight of the pump is not UNBALANCED.

Failure to observe this precaution can result in serious accidents.

Handle the cables very carefully. If they are bent or pulled excessively, the cable and the cable entry may be damaged, resulting in insulation failure. Also, care is needed to protect cable ends against water intrusion.

**CAUTION**

Before installation check rotation. Correct rotation is clockwise when viewed from top of motor. Read ELECTRICAL WIRING.

1. Clean the installation area.
2. Under no circumstances should the cable be pulled while the pump is being transported or installed. Attach a chain or rope to the grip and install the pump.
3. This pump must not be installed on its side. Ensure that it is installed upright on a secure base.
4. Install the pump at a location in the tank where there is the least turbulence.
5. If there is a flow of liquid inside the tank, support the cable where appropriate (See Fig. 1).
6. Install piping so that air will not be entrapped. If piping must be installed in such a way that air pockets are unavoidable, install an air release valve wherever such air pockets are most likely to develop.
7. Do not permit end of discharge piping to be submerged, as backflow will result when the pump is shut down.
8. Non-automatic pumps (model DLFU, DLFMU) do not have an automatic operating system based on built-in floats. Do not operate the pump for a long time with the water level near the minimum operating level as the automatic cut-off switch incorporated inside the motor will be activated.

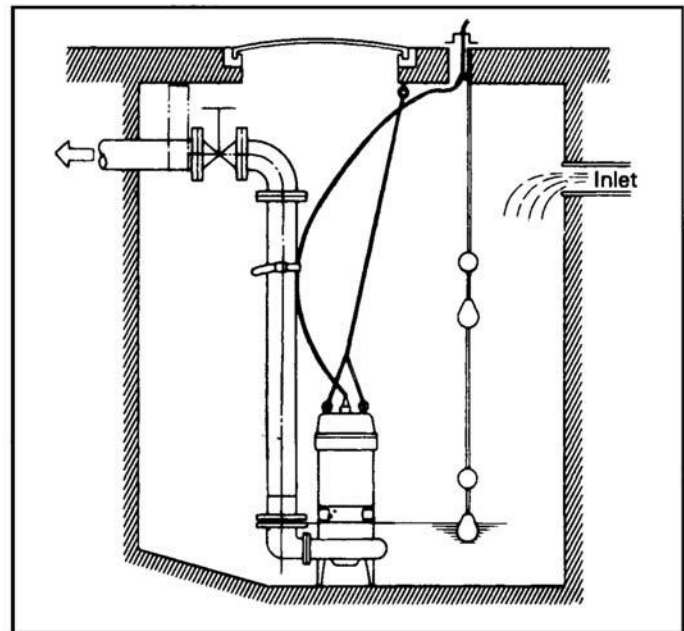

**Fig. 1**

To avoid dry operation, install an automatic operating system, as shown in Fig. 2 and maintain a safe operating water level.

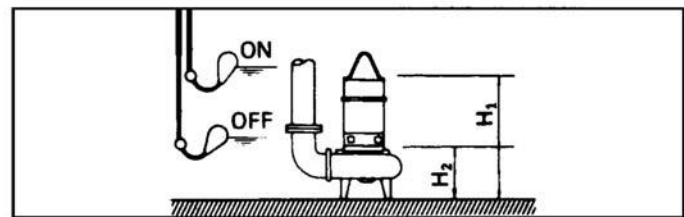

**Fig. 2**

H<sub>1</sub>: Operating water level  
 This must be above the top of the motor.  
 H<sub>2</sub>: Lowest water level (motor flange)

Operating, Installation, and Maintenance

Installation

3. Electrical Wiring:



**WARNING**

Check that the power is locked off and disconnected before working on pump. All electrical work should be performed by a qualified electrician and all national and local electrical codes must be observed.

(1) Wiring

- a) Wire as indicated for the appropriate start system as shown in Fig. 3.
- b) Loose connections will stop the pump. Make sure all electrical connections are secure.

Output 2 to 5HP

208/230V

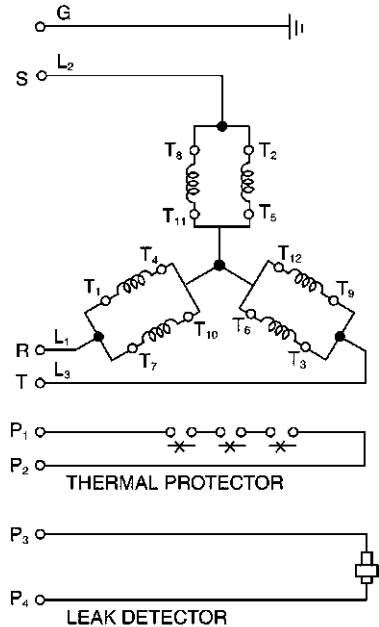

- G – GRN
- L<sub>1</sub> – RED – T<sub>1</sub> – T<sub>7</sub>
- L<sub>2</sub> – WHT – T<sub>2</sub> – T<sub>8</sub>
- L<sub>3</sub> – BLK – T<sub>3</sub> – T<sub>9</sub>
- T<sub>4</sub> – T<sub>5</sub> – T<sub>6</sub> – T<sub>10</sub> – T<sub>11</sub> – T<sub>12</sub>
- P<sub>1</sub> – RED
- P<sub>2</sub> – WHT
- P<sub>3</sub> – BLK
- P<sub>4</sub> – OR
- G – GRN

460V

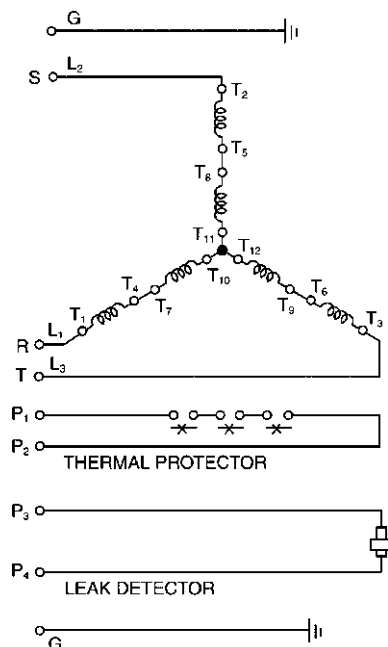

- G – GRN
- L<sub>1</sub> – RED – T<sub>1</sub>
- L<sub>2</sub> – WHT – T<sub>2</sub>
- L<sub>3</sub> – BLK – T<sub>3</sub>
- T<sub>4</sub> – T<sub>7</sub>
- T<sub>5</sub> – T<sub>8</sub>
- T<sub>6</sub> – T<sub>9</sub>
- T<sub>10</sub> – T<sub>11</sub> – T<sub>12</sub>
- P<sub>1</sub> – RED
- P<sub>2</sub> – WHT
- P<sub>3</sub> – BLK
- P<sub>4</sub> – ORG
- G – GRN



Operating, Installation, and Maintenance

Installation – Electrical Wiring

Output 7.5 to 10HP

208/230V

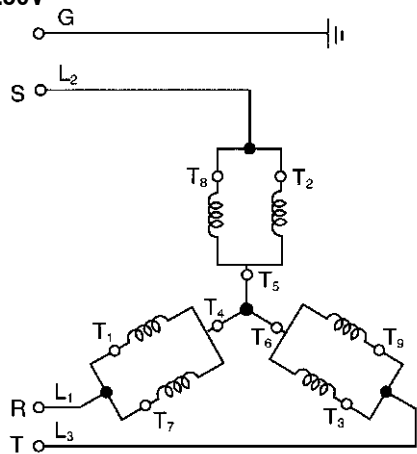

- G – GRN
- L<sub>1</sub> – RED – T<sub>1</sub> – T<sub>7</sub>
- L<sub>2</sub> – WHT – T<sub>2</sub> – T<sub>8</sub>
- L<sub>3</sub> – BLK – T<sub>3</sub> – T<sub>9</sub>
- T<sub>4</sub> – T<sub>5</sub> – T<sub>6</sub>
- P<sub>1</sub> – RED
- P<sub>2</sub> – WHT
- P<sub>3</sub> – BLK
- P<sub>4</sub> – ORG
- G – GRN

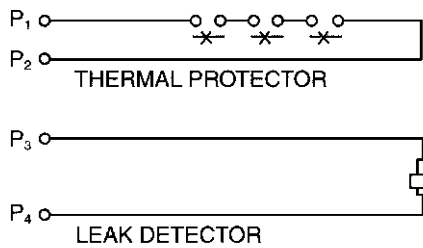

THERMAL PROTECTOR

LEAK DETECTOR

460V

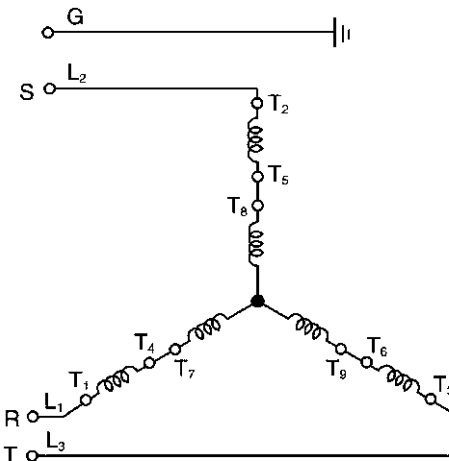

- G – GRN
- L<sub>1</sub> – RED – T<sub>1</sub>
- L<sub>2</sub> – WHT – T<sub>2</sub>
- L<sub>3</sub> – BLK – T<sub>3</sub>
- T<sub>4</sub> – T<sub>7</sub>
- T<sub>5</sub> – T<sub>8</sub>
- T<sub>6</sub> – T<sub>9</sub>
- P<sub>1</sub> – RED
- P<sub>2</sub> – WHT
- P<sub>3</sub> – BLK
- P<sub>4</sub> – ORG
- G – GRN

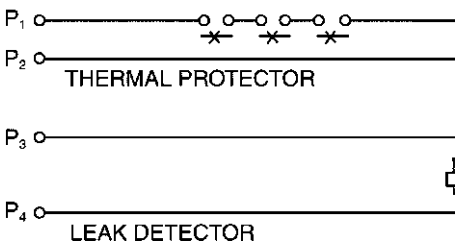

THERMAL PROTECTOR

LEAK DETECTOR

Operating, Installation, and Maintenance

Installation – Electrical Wiring

Output 15 to 30HP

208/230V

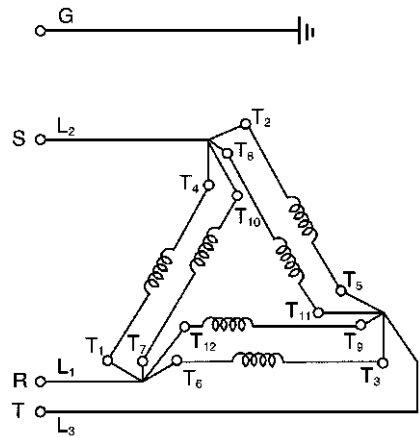

- G – GRN
- L<sub>1</sub> – RED – T<sub>1</sub> – T<sub>7</sub> – T<sub>6</sub> – T<sub>12</sub>
- L<sub>2</sub> – WHT – T<sub>4</sub> – T<sub>8</sub> – T<sub>2</sub> – T<sub>10</sub>
- L<sub>3</sub> – BLK – T<sub>3</sub> – T<sub>9</sub> – T<sub>5</sub> – T<sub>11</sub>
- P<sub>1</sub> – RED
- P<sub>2</sub> – WHT
- P<sub>3</sub> – BLK
- P<sub>4</sub> – ORG
- G – GRN

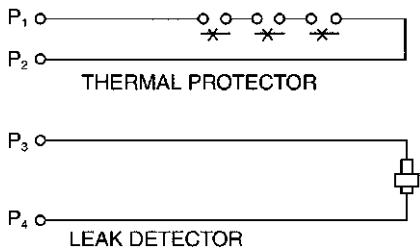

460V

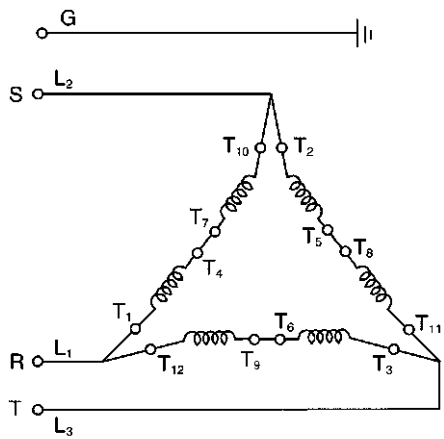

- G – GRN
- L<sub>1</sub> – RED – T<sub>1</sub> – T<sub>12</sub>
- L<sub>2</sub> – WHT – T<sub>2</sub> – T<sub>10</sub>
- L<sub>3</sub> – BLK – T<sub>3</sub> – T<sub>11</sub>
- T<sub>4</sub> – T<sub>7</sub>
- T<sub>5</sub> – T<sub>8</sub>
- T<sub>6</sub> – T<sub>9</sub>
- P<sub>1</sub> – RED
- P<sub>2</sub> – WHT
- P<sub>3</sub> – BLK
- P<sub>4</sub> – ORG
- G – GRN

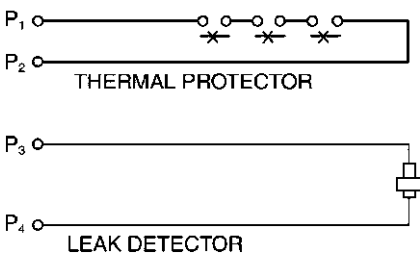

Operating, Installation, and Maintenance

Installation – Electrical Wiring

Output 40 to 60HP

208/230V

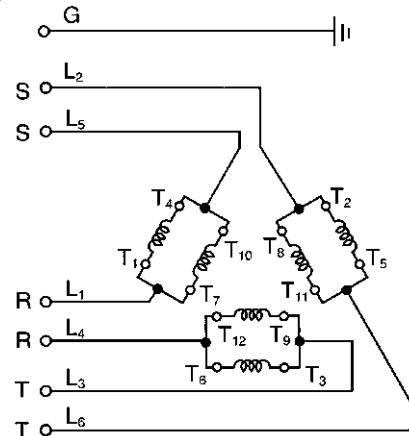

- G – GRN
- L<sub>1</sub> – RED – T<sub>1</sub> – T<sub>7</sub>
- L<sub>2</sub> – WHT – T<sub>2</sub> – T<sub>8</sub>
- L<sub>3</sub> – BLK – T<sub>3</sub> – T<sub>9</sub>
- L<sub>5</sub> – WHT – T<sub>4</sub> – T<sub>10</sub>
- L<sub>6</sub> – BLK – T<sub>5</sub> – T<sub>11</sub>
- L<sub>4</sub> – RED – T<sub>6</sub> – T<sub>12</sub>
- P<sub>1</sub> – RED
- P<sub>2</sub> – WHT
- P<sub>3</sub> – BLK
- P<sub>4</sub> – ORG
- G – GRN

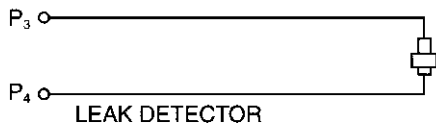
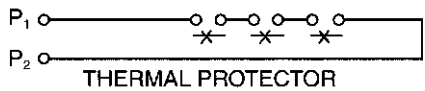

460V

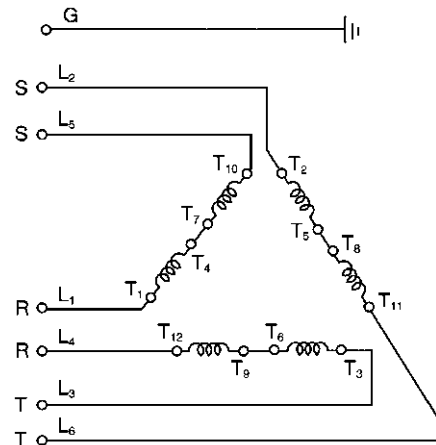

- G – GRN
- L<sub>1</sub> – RED – T<sub>1</sub>
- L<sub>2</sub> – WHT – T<sub>2</sub>
- L<sub>3</sub> – BLK – T<sub>3</sub>
- L<sub>5</sub> – WHT – T<sub>10</sub>
- L<sub>6</sub> – BLK – T<sub>11</sub>
- L<sub>4</sub> – RED – T<sub>12</sub>
- T<sub>4</sub> – T<sub>7</sub>
- T<sub>5</sub> – T<sub>8</sub>
- T<sub>6</sub> – T<sub>9</sub>
- P<sub>1</sub> – RED
- P<sub>2</sub> – WHT
- P<sub>3</sub> – BLK
- P<sub>4</sub> – OR
- G – GRN

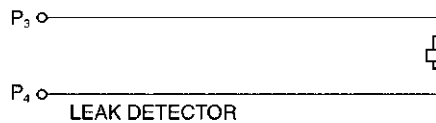
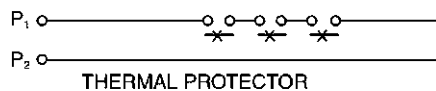



**Operating, Installation, and Maintenance**

**Installation**

(2) Cable

- a) Never let the end of the cable contact water
- b) If the cable is extended, do not immerse the splice in water.
- c) Fasten the cable to the discharge piping with tape or vinyl strips.
- d) Install the cable so that it will not overheat.  
Overheating is caused by coiling the cable and exposing it to direct sunlight.

(3) Grounding

As shown in Fig. 4 ground the green wire (label E). Under no circumstances should the green wire be connected to the power supply.

- (4) Use short circuit breakers to prevent danger of electrical shock.

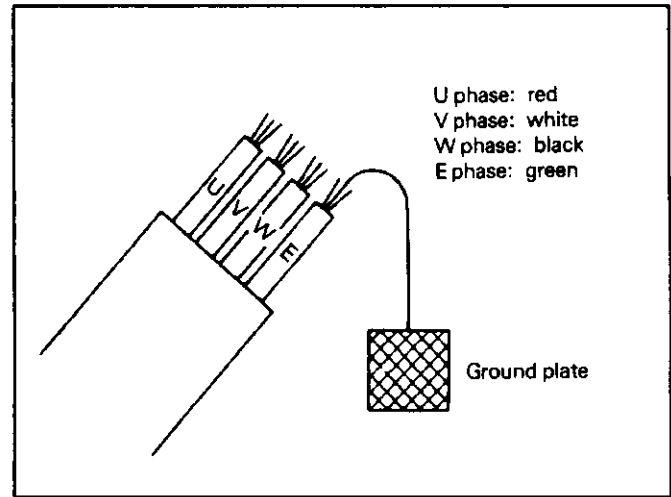

**Fig. 4**

**Operation**

**1. Before starting the pump:**

- (1) After completing installation, measure the insulation resistance again as described in INSTALLATION.
- (2) Check water level.

If the pump is operated continuously for an extended period of time in a dry condition or at the lowest water level, the thermal protector will be activated.

Constant repetition of this action will shorten pump service life. Do not start the pump again in such a situation until after the motor has completely cooled.

**2. Test Operation:**

**⚠ CAUTION**

Check rotation. Correct rotation is clockwise when viewed from top of motor. Pump should be started with gate valve closed, and then the operator should open the valve gradually.

(1) Model DL(K)FU, DL(K)MFU

- a) Turn the operating switch on and off a couple of times to check for normal pump start.
- b) Check the direction of rotation. If discharge volume is low or unusual sounds are heard when the pump is operating, rotation has been reversed. When this happens, reverse two of the three wires.
- c) Check amperage, voltage, and head pressure.

**Maintenance and Service**



**⚠ WARNING**

Disconnect power cable from power source before servicing unit.  
Normal maintenance should be done by qualified personnel.

Check pressure, output, voltage, current, vibration, and other specifications. Unusual readings may indicate a problem requiring immediate service. Contact your local EBARA INTERNATIONAL CORPORATION representative as soon as possible.

**Operating, Installation, and Maintenance**

**Maintenance and Service**

**1. Daily inspections:**

(1) Check current and ammeter fluctuation daily. If ammeter fluctuation is great, even though within the limits of pump rating, foreign matter may be clogging the pump. If the quantity of liquid discharged falls suddenly, foreign matter may be blocking the suction inlet.

**2. Regular inspections:**

(1) Monthly inspections

Measure the insulation resistance. The value should be more than 1 mega ohm. If resistance starts to fall rapidly even with an initial indication of over 1 mega ohm, this may be an indication of trouble and repair work is required.

(2) Every 6 months

Check the mechanical seal every six months. If you notice water mixed with the oil or cloudy texture of the oil, these may be indications of a defective mechanical seal requiring replacement. The service life of the mechanical seal can be prolonged by replacing the oil in the mechanical seal chamber once a year. When replacing the oil, lay the pump on its side, with filler plug on top as shown in Fig. 5.

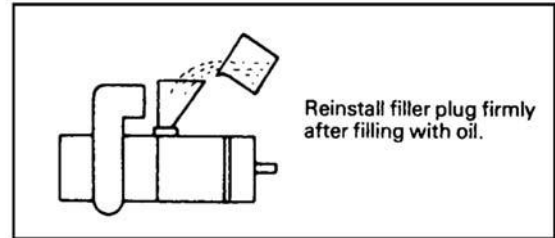

**Fig. 5**

**Oil Capacities for DLF/DLFMU pumps**

HP	Oil	HP	Oil
2	31 ozs	20	120 ozs
3	42 ozs	25	115 ozs
5	47 ozs	30	120 ozs
7½	75 ozs	40	220 ozs
10	75 ozs	50	240 ozs
15	75 ozs	60	240 ozs

**Table 1**

(3) Preventive maintenance yearly

Conduct an overhaul of the pump annually. These intervals will reduce the possibility of future trouble.

**3. Parts that will need to be replaced:**

Replace the appropriate part when the following conditions are apparent.

Replaceable Part	Mechanical Seal	Oil Filter plug gasket	Lubricating oil	O-ring
Replacement guide	Whenever oil in mechanical seal chamber is clouded	Whenever oil is replaced or inspected	Whenever clouded or dirty	Whenever pump is overhauled
Frequency	Annually	Annually	Annually	Annually

Above replacement schedule is based on normal operating conditions.

**Operating, Installation, and Maintenance**

**Troubleshooting**



All service should be done by factory trained or qualified personnel only.

Trouble	Cause	Remedy
Does not start. Starts, but immediately stops.	(1) Power failure (2) Large discrepancy between power source and voltage (3) Significant drop in voltage (4) Motor phase malfunction (5) Electric circuit connection faulty (6) Faulty connection of control circuit (7) Blown fuse (8) Faulty magnetic switch (9) Water is not at level indicated by float (10) Float is not in appropriate level (11) Float defective (12) Short circuit breaker is functioning (13) Foreign matter clogging pump (14) Motor burned out (15) Motor bearing broken	(1)-(3) Contact electric power company; devise counter-measures  (4) Inspect connections and magnetic switch (5) Inspect electric circuit (6) Correct wiring (7) Replace with correct type of fuse (8) Replace with correct type of magnetic switch (9) Raise water level (10) Move float to an appropriate starting level (11) Repair or replace (12) Repair location of short circuit (13) Remove foreign matter (14) Repair or replace (15) Repair or replace
Operates, but stops after a while.	(1) Prolonged dry operation has activated motor protector and caused pump to stop (2) High liquid temperature has activated motor protector and caused pump to stop	(1) Raise stop water level (2) Lower liquid temperature
Does not pump. Inadequate volume.	(1) Reverse rotation (2) Significant drop in voltage  (3) Operating a 60Hz pump on 50Hz (4) Discharge head is high (5) Large piping loss (6) Low operating water level causes air suction (7) Leaking from discharge piping (8) Clogging of discharge piping (9) Foreign Matter in suction inlet (10) Foreign matter clogging pump (11) Worn impeller	(1) Correct rotation (see Operation 2, (3)) (2) Contact electric power company and devise counter-measures (3) Check nameplate (4) Recalculate and adjust (5) Recalculate and adjust (6) Raise water level or lower pump (7) Inspect, repair (8) Remove foreign matter (9) Remove foreign matter (10) Disassemble and remove foreign matter (11) Replace impeller
Over current	(1) Unbalanced current and voltage (2) Significant voltage drop (3) Motor phase malfunction (4) Operating 50HZ pump on 60Hz (5) Reverse rotation (6) Low head; excessive volume of water (7) Foreign matter clogging pump (8) Motor bearing is worn or damaged	(1) Contact electric power company and devise counter-measure (2) Contact electric power company and devise counter-measure (3) Inspect connections and magnetic switch (4) Check nameplate (5) Correct rotation (see Operation 2. (3)) (6) Replace pump with low head pump (7) Disassemble and remove foreign matter (8) Replace bearing
Pump vibrates; excessive operating noise.	(1) Reverse rotation (2) Pump clogged with foreign matter (3) Piping resonates (4) Gate valve is closed too far	(1) Correct rotation (2) Disassemble and remove foreign matter (3) Improve piping (4) Open gate valve

**2 to 5HP**

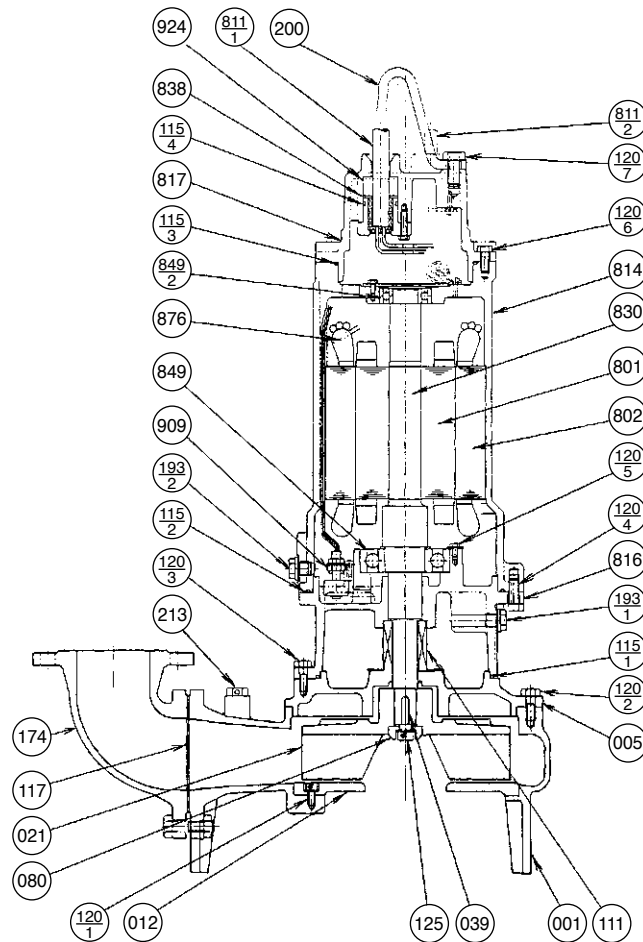

PART NO.	PART NAME	MATERIAL	ASTM, AISI CODE	NO. FOR 1 UNIT
001	CASING	CAST IRON	A48 Class 30	1
005	INTERMEDIATE CASING	CAST IRON	A48 Class 30	1
†012	SUCTION COVER	CAST IRON	A48 Class 30	1
†021	IMPELLER	CAST IRON	A48 Class 30	1
039	KEY	420 STAINLESS	AISI420	1
080	BUSHING	STEEL	A283 Grade D	1
†111	MECHANICAL SEAL	—		1 SET
†115-1	O-RING	RUBBER (NBR)		1
†115-2	O-RING	RUBBER (NBR)		1
†115-3	O-RING	RUBBER (NBR)		1
†115-4	O-RING	RUBBER (NBR)		2
†117	GASKET			1
120-1	BOLT	304 STAINLESS	AISI304	4
120-2	BOLT	304 STAINLESS	AISI304	8
120-3	BOLT	304 STAINLESS	AISI304	4
120-4	BOLT	304 STAINLESS	AISI304	4
120-5	BOLT	304 STAINLESS	AISI304	3
120-6	BOLT	304 STAINLESS	AISI304	4
120-7	BOLT	304 STAINLESS	AISI304	2
125	BOLT	304 STAINLESS	AISI304	1

PART NO.	PART NAME	MATERIAL	ASTM, AISI CODE	NO. FOR 1 UNIT
174	DISCHARGE ELBOW	CAST IRON	A48 Class 30	1
193-1	PLUG	304 STAINLESS	AISI304	1
193-2	PLUG	304 STAINLESS	AISI304	1
200	LIFTING HANGER	STEEL	A283 Grade D	1
213	AIR VENT VALVE	BRASS	B36 No. 272	1
801	ROTOR	—		1
802	STATOR	—		1
811-1	POWER CABLE	—		1
811-2	CONTROL CABLE	—		1
814	MOTOR COVER	CAST IRON	A48 Class 30	1
816	BRACKET	CAST IRON	A48 Class 30	1
817	BRACKET	CAST IRON	A48 Class 30	1
830	SHAFT	403 STAINLESS	AISI403	1
838	WASHER	304 STAINLESS	AISI304	2
†849-1	BALL BEARING	—		1
†849-2	BALL BEARING	—		1
876	MOTOR PROTECTOR	—		3
909	LEAKAGE DETECTOR	—		1
924	PACKING	RUBBER (NBR)		2

Motors are purchased as a complete unit  
 †: Recommended spare parts



7½ to 10HP

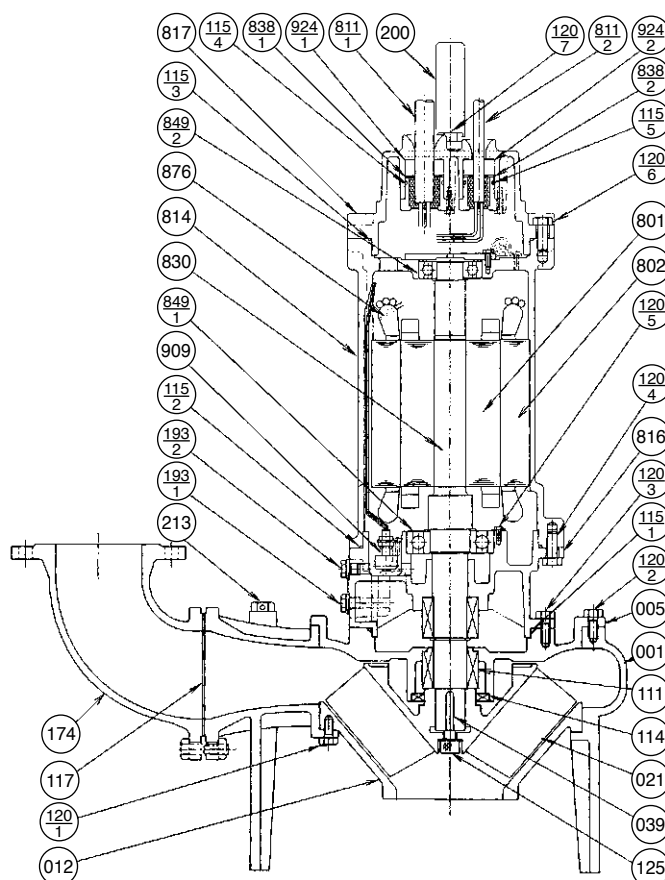

PART NO.	PART NAME	MATERIAL	ASTM, AISI CODE	NO. FOR 1 UNIT
001	CASING	CAST IRON	A48 Class 30	1
005	INTERMEDIATE CASING	CAST IRON	A48 Class 30	1
†012	SUCTION COVER	CAST IRON	A48 Class 30	1
†021	IMPELLER	CAST IRON	A48 Class 30	1
039	KEY	420 STAINLESS	AISI420	1
†111	MECHANICAL SEAL	—		1 SET
†114	OIL SEAL	RUBBER (NBR)		1
†115-1	O-RING	RUBBER (NBR)		1
†115-2	O-RING	RUBBER (NBR)		1
†115-3	O-RING	RUBBER (NBR)		1
†115-4	O-RING	RUBBER (NBR)		1
†115-5	O-RING	RUBBER (NBR)		1
†117	GASKET			1
120-1	BOLT	304 STAINLESS	AISI304	4
120-2	BOLT	304 STAINLESS	AISI304	8
120-3	BOLT	304 STAINLESS	AISI304	4
120-4	BOLT	304 STAINLESS	AISI304	6
120-5	BOLT	304 STAINLESS	AISI304	3
120-6	BOLT	304 STAINLESS	AISI304	4
120-7	BOLT	304 STAINLESS	AISI304	2
125	BOLT	304 STAINLESS	AISI304	1

PART NO.	PART NAME	MATERIAL	ASTM, AISI CODE	NO. FOR 1 UNIT
174	DISCHARGE ELBOW	CAST IRON	A48 Class 30	1
193-1	PLUG	304 STAINLESS	AISI304	1
193-2	PLUG	304 STAINLESS	AISI304	1
200	LIFTING HANGER	STEEL	A283 Grade D	1
213	AIR VENT VALVE	BRASS	B36 No. 272	1
801	ROTOR	—		1
802	STATOR	—		1
811-1	POWER CABLE	—		1
811-2	CONTROL CABLE	—		1
814	MOTOR COVER	CAST IRON	A48 Class 30	1
816	BRACKET	CAST IRON	A48 Class 30	1
817	BRACKET	CAST IRON	A48 Class 30	1
830	SHAFT	420J2 STAINLESS	AISI420	1
838-1	WASHER	304 STAINLESS	AISI304	1
838-2	WASHER	304 STAINLESS	AISI304	1
†849-1	BALL BEARING	—		1
†849-2	BALL BEARING	—		1
876	MOTOR PROTECTOR	—		3
909	LEAKAGE DETECTOR	—		1
924-1	PACKING	RUBBER (NBR)		1
924-2	PACKING	RUBBER (NBR)		1

Motors are purchased as a complete unit  
 †: Recommended spare parts



15 to 30HP

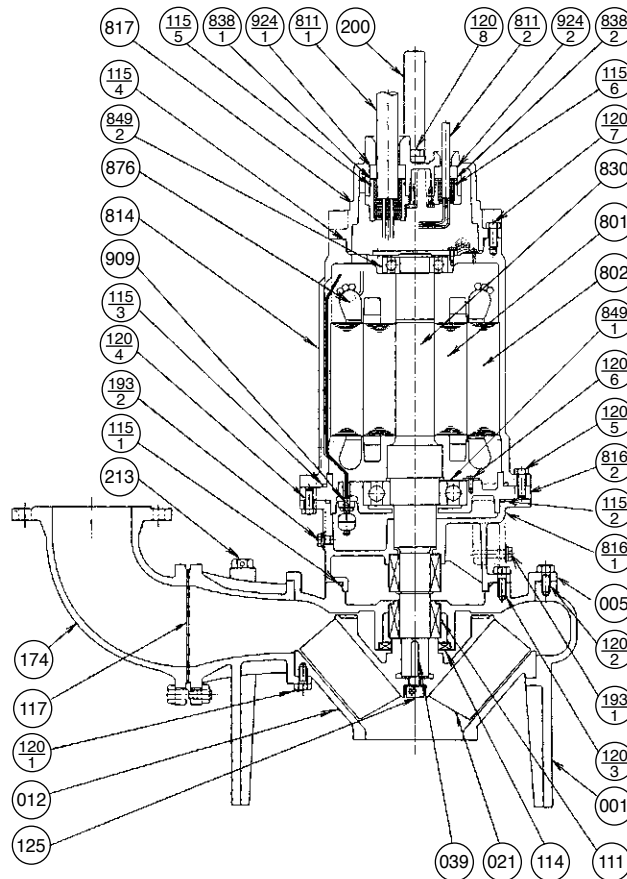

PART NO.	PART NAME	MATERIAL	ASTM, AISI CODE	NO. FOR 1 UNIT	PART NO.	PART NAME	MATERIAL	ASTM, AISI CODE	NO. FOR 1 UNIT
001	CASING	CAST IRON	A48 Class 30	1	174	DISCHARGE ELBOW	CAST IRON	A48 Class 30	1
005	INTERMEDIATE CASING	CAST IRON	A48 Class 30	1	193-1	PLUG	304 STAINLESS	AISI304	1
†012	SUCTION COVER	CAST IRON	A48 Class 30	1	193-2	PLUG	304 STAINLESS	AISI304	1
†021	IMPELLER	CAST IRON	A48 Class 30	1	200	LIFTING HANGER	STEEL	A283 Grade D	1
039	KEY	420 STAINLESS	AISI420	1	213	AIR VENT VALVE	BRASS	B36 No. 272	1
†111	MECHANICAL SEAL	—		1 SET	801	ROTOR	—		1
†114	OIL SEAL	RUBBER (NBR)		1	802	STATOR	—		1
†115-1	O-RING	RUBBER (NBR)		1	811-1	POWER CABLE	—		1
†115-2	O-RING	RUBBER (NBR)		1	811-2	CONTROL CABLE	—		1
†115-3	O-RING	RUBBER (NBR)		1	814	MOTOR COVER	CAST IRON	A48 Class 30	1
†115-4	O-RING	RUBBER (NBR)		1	816-1	BRACKET	CAST IRON	A48 Class 30	1
†115-5	O-RING	RUBBER (NBR)		1	816-2	BRACKET	CAST IRON	A48 Class 30	1
†115-6	O-RING	RUBBER (NBR)		1	817	BRACKET	CAST IRON	A48 Class 30	1
†117	GASKET			1	830	SHAFT	420J2 STAINLESS	AISI420	1
120-1	BOLT	304 STAINLESS	AISI304	4	838-1	WASHER	304 STAINLESS	AISI304	1
120-2	BOLT	304 STAINLESS	AISI304	8	838-2	WASHER	304 STAINLESS	AISI304	1
120-3	BOLT	304 STAINLESS	AISI304	4	†849-1	BALL BEARING	—		1
120-4	BOLT	304 STAINLESS	AISI304	6	†849-2	BALL BEARING	—		1
120-5	BOLT	304 STAINLESS	AISI304	6	876	MOTOR PROTECTOR	—		3
120-6	BOLT	304 STAINLESS	AISI304	3	909	LEAKAGE DETECTOR	—		1
120-7	BOLT	304 STAINLESS	AISI304	6	924-1	PACKING	RUBBER (NBR)		1
120-8	BOLT	304 STAINLESS	AISI304	2	924-2	PACKING	RUBBER (NBR)		1
125	BOLT	304 STAINLESS	AISI304	1					

Motors are purchased as a complete unit  
 †: Recommended spare parts



**40 to 60HP  
100DLFU**

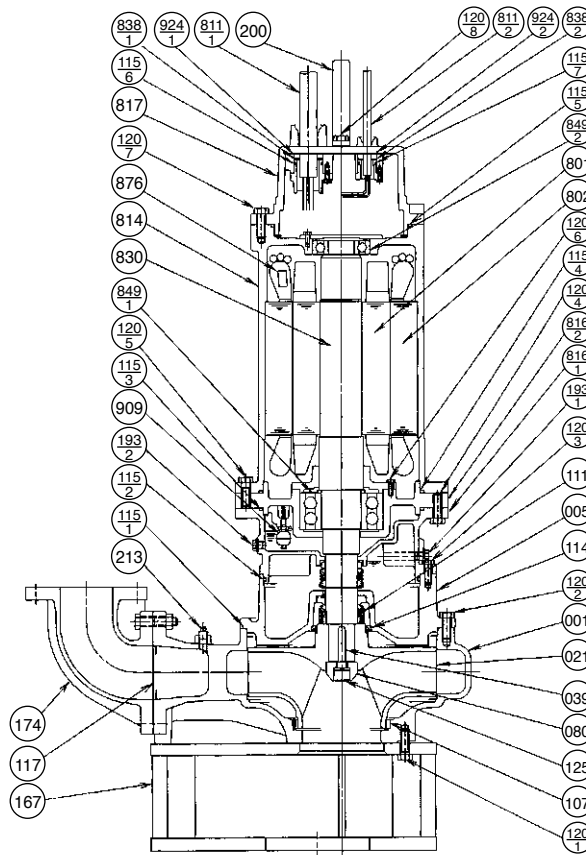

PART NO.	PART NAME	MATERIAL	ASTM, AISI CODE	NO. FOR 1 UNIT	PART NO.	PART NAME	MATERIAL	ASTM, AISI CODE	NO. FOR 1 UNIT
001	CASING	CAST IRON	A48 Class 30	1	125	BOLT	304 STAINLESS	AISI304	1
005	INTERMEDIATE CASING	CAST IRON	A48 Class 30	1	*167	BASE	STEEL	A283 Grade D	1
†021	IMPELLER	CAST IRON	A48 Class 30	1	174	DISCHARGE ELBOW	CAST IRON	A48 Class 30	1
039	KEY	420 STAINLESS	AISI420	1	193-1	PLUG	304 STAINLESS	AISI304	1
080	BUSHING	304 STAINLESS	AISI 304	1	193-2	PLUG	304 STAINLESS	AISI304	1
†107	WEARING RING	304 STAINLESS	AISI 304	1	200	LIFTING HANGER	STEEL	A283 Grade D	1
†111	MECHANICAL SEAL	—	—	1 SET	213	AIR VENT VALVE	BRASS	B36 No. 272	1
†114	OIL SEAL	RUBBER (NBR)	—	1	801	ROTOR	—	—	1
†115-1	O-RING	RUBBER (NBR)	—	1	802	STATOR	—	—	1
†115-2	O-RING	RUBBER (NBR)	—	1	811-1	POWER CABLE	—	—	2
†115-3	O-RING	RUBBER (NBR)	—	1	811-2	CONTROL CABLE	—	—	1
†115-4	O-RING	RUBBER (NBR)	—	1	814	MOTOR COVER	CAST IRON	A48 Class 30	1
†115-5	O-RING	RUBBER (NBR)	—	1	816-1	BRACKET	CAST IRON	A48 Class 30	1
†115-6	O-RING	RUBBER (NBR)	—	2	816-2	BRACKET	CAST IRON	A48 Class 30	1
†115-7	O-RING	RUBBER (NBR)	—	1	817	BRACKET	CAST IRON	A48 Class 30	1
†117	GASKET	—	—	1	830	SHAFT	420J2 STAINLESS	AISI420	1
120-1	BOLT	304 STAINLESS	AISI304	8	838-1	WASHER	304 STAINLESS	AISI304	2
120-2	BOLT	304 STAINLESS	AISI304	8	838-2	WASHER	304 STAINLESS	AISI304	1
120-3	BOLT	304 STAINLESS	AISI304	8	†849-1	BALL BEARING	—	—	1 SET
120-4	BOLT	304 STAINLESS	AISI304	8	†849-2	BALL BEARING	—	—	1
120-5	BOLT	304 STAINLESS	AISI304	6	876	MOTOR PROTECTOR	—	—	3
120-6	BOLT	304 STAINLESS	AISI304	4	909	LEAKAGE DETECTOR	—	—	1
120-7	BOLT	304 STAINLESS	AISI304	6	924-1	PACKING	RUBBER (NBR)	—	2
120-8	BOLT	304 STAINLESS	AISI304	2	924-2	PACKING	RUBBER (NBR)	—	1

Motors are purchased as a complete unit

†: Recommended spare parts

\*: Option for hard-piped installations



**Operating, Installation, and Maintenance**

**40 to 60HP  
150DLFU  
200DLFU  
250DLFU  
300DLFU**

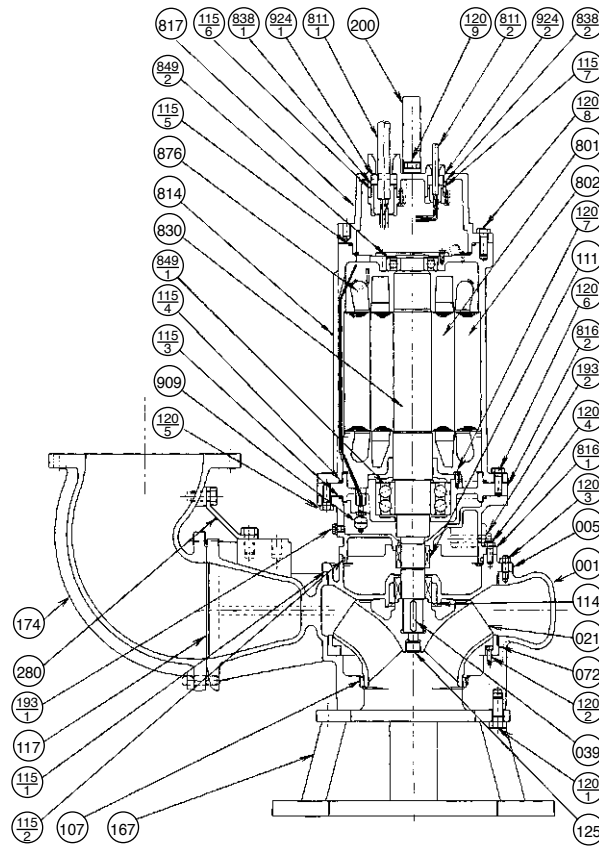

PART NO.	PART NAME	MATERIAL	ASTM, AISI CODE	NO. FOR 1 UNIT	PART NO.	PART NAME	MATERIAL	ASTM, AISI CODE	NO. FOR 1 UNIT
001	CASING	CAST IRON	A48 Class 30	1	125	BOLT	304 STAINLESS	AISI304	1
005	INTERMEDIATE CASING	CAST IRON	A48 Class 30	1	*167	BASE	STEEL	A283 Grade D	1
†021	IMPELLER	DUCTILE IRON	A536 60-40-18	1	174	DISCHARGE ELBOW	CAST IRON	A48 Class 30	1
039	KEY	420 STAINLESS	AISI420	1	193-1	PLUG	304 STAINLESS	AISI304	1
†072	SIDE RING	CAST IRON	A48 Class 30	1	193-2	PLUG	304 STAINLESS	AISI304	1
†107	WEARING RING	304 STAINLESS	AISI304	1	200	LIFTING HANGER	STEEL	A283 Grade D	1
†111	MECHANICAL SEAL	—		1 SET	280	ELBOW SUPPORT	STEEL	A283 Grade D	2
†114	OIL SEAL	RUBBER (NBR)		1	801	ROTOR	—		1
†115-1	O-RING	RUBBER (NBR)		1	802	STATOR	—		1
†115-2	O-RING	RUBBER (NBR)		1	811-1	POWER CABLE	—		2
†115-3	O-RING	RUBBER (NBR)		1	811-2	CONTROL CABLE	—		1
†115-4	O-RING	RUBBER (NBR)		1	814	MOTOR COVER	CAST IRON	A48 Class 30	1
†115-5	O-RING	RUBBER (NBR)		1	816-1	BRACKET	CAST IRON	A48 Class 30	1
†115-6	O-RING	RUBBER (NBR)		2	816-2	BRACKET	CAST IRON	A48 Class 30	1
†115-7	O-RING	RUBBER (NBR)		1	817	BRACKET	CAST IRON	A48 Class 30	1
†117	GASKET			1	830	SHAFT	420J2 STAINLESS	AISI420	1
120-1	BOLT	304 STAINLESS	AISI304	3/4	838-1	WASHER	304 STAINLESS	AISI304	2
120-2	BOLT	304 STAINLESS	AISI304	4	838-2	WASHER	304 STAINLESS	AISI304	1
120-3	BOLT	304 STAINLESS	AISI304	8	†849-1	BALL BEARING	—		1 SET
120-4	BOLT	304 STAINLESS	AISI304	4	†849-2	BALL BEARING	—		1
120-5	BOLT	304 STAINLESS	AISI304	8	876	MOTOR PROTECTOR	—		3
120-6	BOLT	304 STAINLESS	AISI304	8	909	LEAKAGE DETECTOR	—		1
120-7	BOLT	304 STAINLESS	AISI304	4	924-1	PACKING	RUBBER (NBR)		2
120-8	BOLT	304 STAINLESS	AISI304	6	924-2	PACKING	RUBBER (NBR)		1
120-9	BOLT	304 STAINLESS	AISI304	2					

Motors are purchased as a complete unit

†: Recommended spare parts

\*: Option for hard-piped installations





**Operating, Installation, and Maintenance**

**Maintenance and Service**

**6. Disassembly and Assembly:**

**⚠ CAUTION**

All service should be done by factory trained or qualified personnel only.  
Be sure to cut off power source before beginning disassembly.

Please contact the following for assistance:

Ebara International Corporation  
Customer Service Manager  
1651 Cedar Line Drive  
Rock Hill, South Carolina 29730

**Thermal Protection**

The motor shall be equipped with a protector such as automatic cut-off device and thermal protector. The motors described below shall incorporate Miniature Thermal Protectors (MTP) which are embedded in the windings.

When temperature of the winding raises and reaches the MTP acting point, the motor protection circuit is activated to protect motor from over heat.

**1. Applicable model**

Model: DGFU, DL(K)FU, DVFU, DDLFU

**2. MTP Specifications:**

Model	KLIXON 9700K-66-215
Type of Contact	b (Normally-Closed contact Acting-open)
Acting Temperature	140±5 C (284±9 F)
Re-setting Temperature	85±10 C (185±18 F)
Capacity of Contact	

Voltage (V)	DC 24	AC 115	AC 230	AC 460
Amperage (A)	18	18	13	5.5

**3. Installation:**

MTP shall be embedded in the stator windings as shown at right –

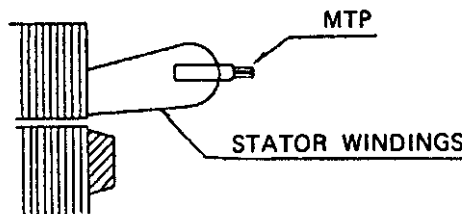

**4. Construction:**

Construction of the MTP is as shown below:

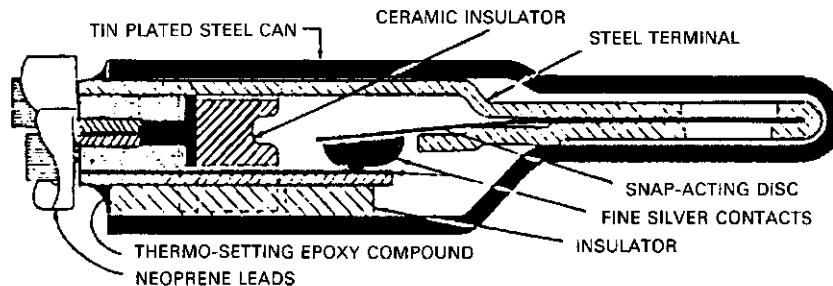

**Operating, Installation, and Maintenance**

**Leakage Detector**

**1. Construction:**

Each switch has a magnet-containing float which senses the liquid level and magnetically actuates a dry reed switch encapsulated within a stem. The switch opens on rise of liquid.

**2. Specifications**

- Apply to 2 to 30HP

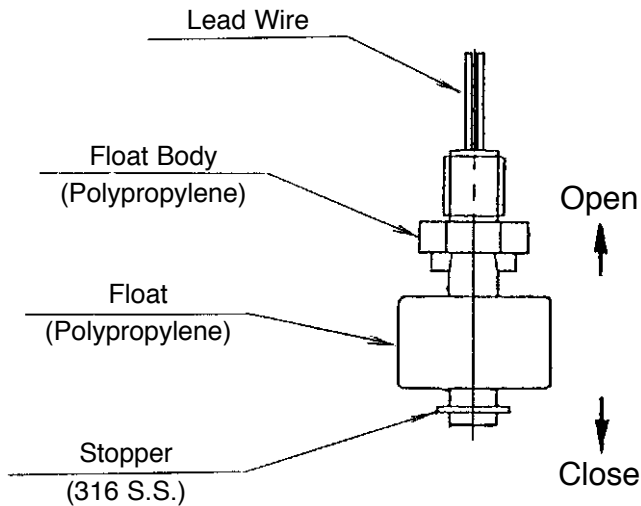

Breaking Capacity : AC50VA, DC50W

Max. Breaking Current : AC0.5A, DC0.5A

Max. Operating Voltage : AC300V, DC300V

- Apply to 40 to 60HP

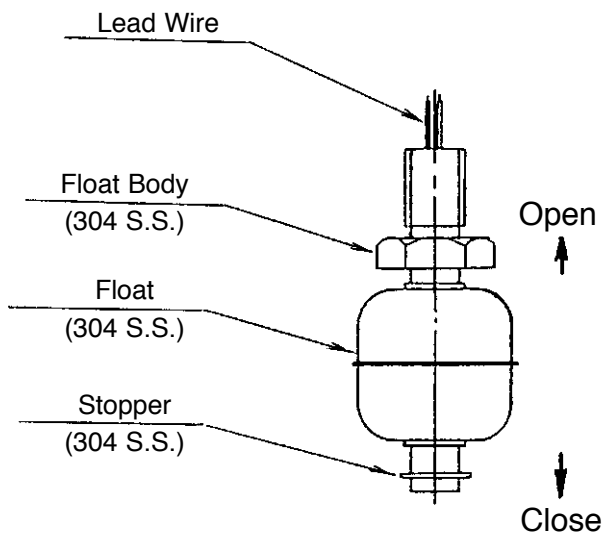

Breaking Capacity : AC12VA, DC10W

Max. Breaking Current : AC0.6A, DC0.5A

Max. Operating Voltage : AC200V, DC200V

---

**Operating, Installation, and Maintenance**

---

**Limited Warranty****1. All specifications subject to change without notice****2. Limited warranty:**

EIC warrants for a period of twelve months from the date of initial startup or eighteen months from the date of shipment, whichever shall first occur (the "Warranty Period") the EIC Products to be delivered hereunder against defects in material and workmanship, under normal use and service when installed, used and maintained in accordance with instructions supplied by EIC. This is EIC's sole and exclusive warranty. It applies only to EIC Products and specifically excludes Other Equipment, whether or not such Other Equipment is included in EIC's scope of supply hereunder. Such Other Equipment is warranted only by its manufacturer. If such a defect appears in EIC Products within the Warranty Period and Purchaser has given EIC immediate written notice of same, EIC will either repair the part, or at its option replace the part, by shipping a similar part F.O.B. EIC's shipping point, or at its option refund an equitable portion of the purchase price. EIC may require the return of the defective part, transportation prepaid, to establish the claim. All costs of removal, reinstallation, field labor and transportation shall be borne by the Purchaser. No allowance will be made for repairs without EIC's written consent or approval, and the Warranty Period shall not be suspended upon stopping operation for warranty repairs, nor recommence upon completion of the warranty repairs, but shall run continuously from commencement until normal expiration. Repair parts shall carry no greater warranty than the remaining balance of the underlying EIC Product into which they may be installed, expiring at the same time as said underlying warranty.

Any descriptions of the EIC Products or Other Equipment, any specifications, and any samples, models, bulletins, or similar material used in connection with this sale are for the sole purpose of identifying the said Equipment and are not to be construed as express or implied warranties. Unless during the warranty period all repairs or replacements or parts or components for EIC Products are with EIC-approved parts or components, and all warranty service is performed by EIC or its authorized distributor or representative, the warranty responsibility of EIC shall immediately terminate.

EIC MAKES NO OTHER WARRANTY OF ANY KIND WHATSOEVER, EXPRESS OR IMPLIED; AND ALL WARRANTIES OF MERCHANTABILITY AND FITNESS FOR A PARTICULAR PURPOSE ARE HEREBY DISCLAIMED BY EIC AND EXCLUDED FROM THESE CONDITIONS. The Purchaser's sole and exclusive remedy, whether upon warranty, contract or tort, including negligence, will be to proceed under this warranty. All liability of EIC shall terminate no later than the expiration of the Warranty Period.



*Contact your dealer or supplier  
for more information about other EBARA products:*



**EBARA International Corporation**

Fluid Handling Division

1651 Cedar Line Drive, Rock Hill, SC 29730

t (803) 327-5005 | f (803) 327-5097

[www.pumpsebara.com](http://www.pumpsebara.com)

© 2016 EBARA International Corporation

EFHD DL(K)FU 1216

Performance Curves

Project: \_\_\_\_\_ GPM: \_\_\_\_\_ TDH: \_\_\_\_\_ EFF: \_\_\_\_\_ HP: \_\_\_\_\_ Chk'd: \_\_\_\_\_ Date: \_\_\_\_\_

50DLKFU61.5 (2HP)

Synchronous Speed 1800 RPM

2, 3 inch discharge

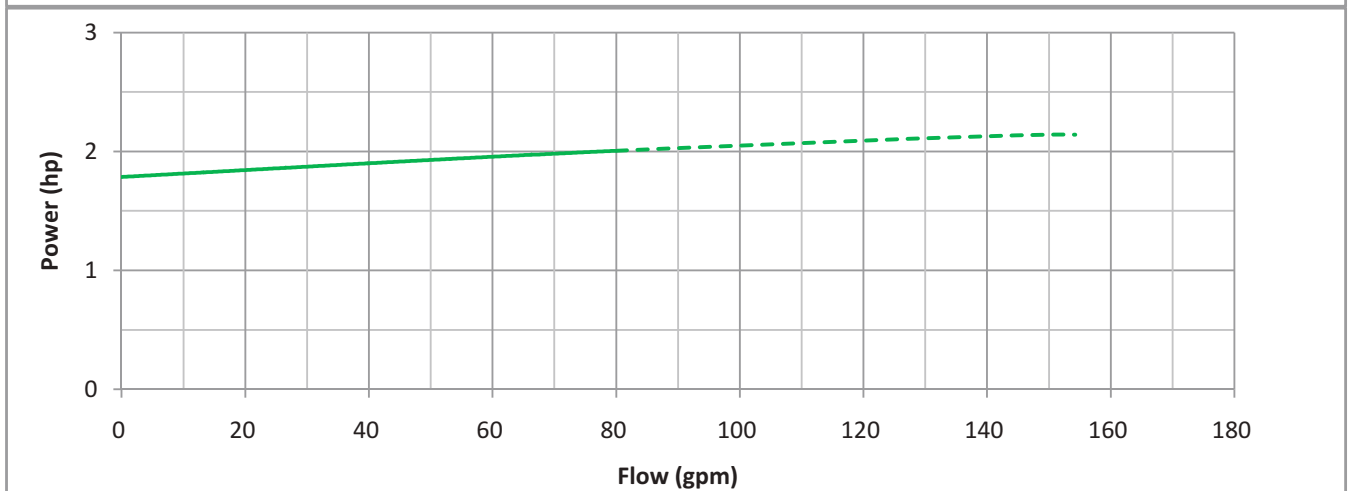
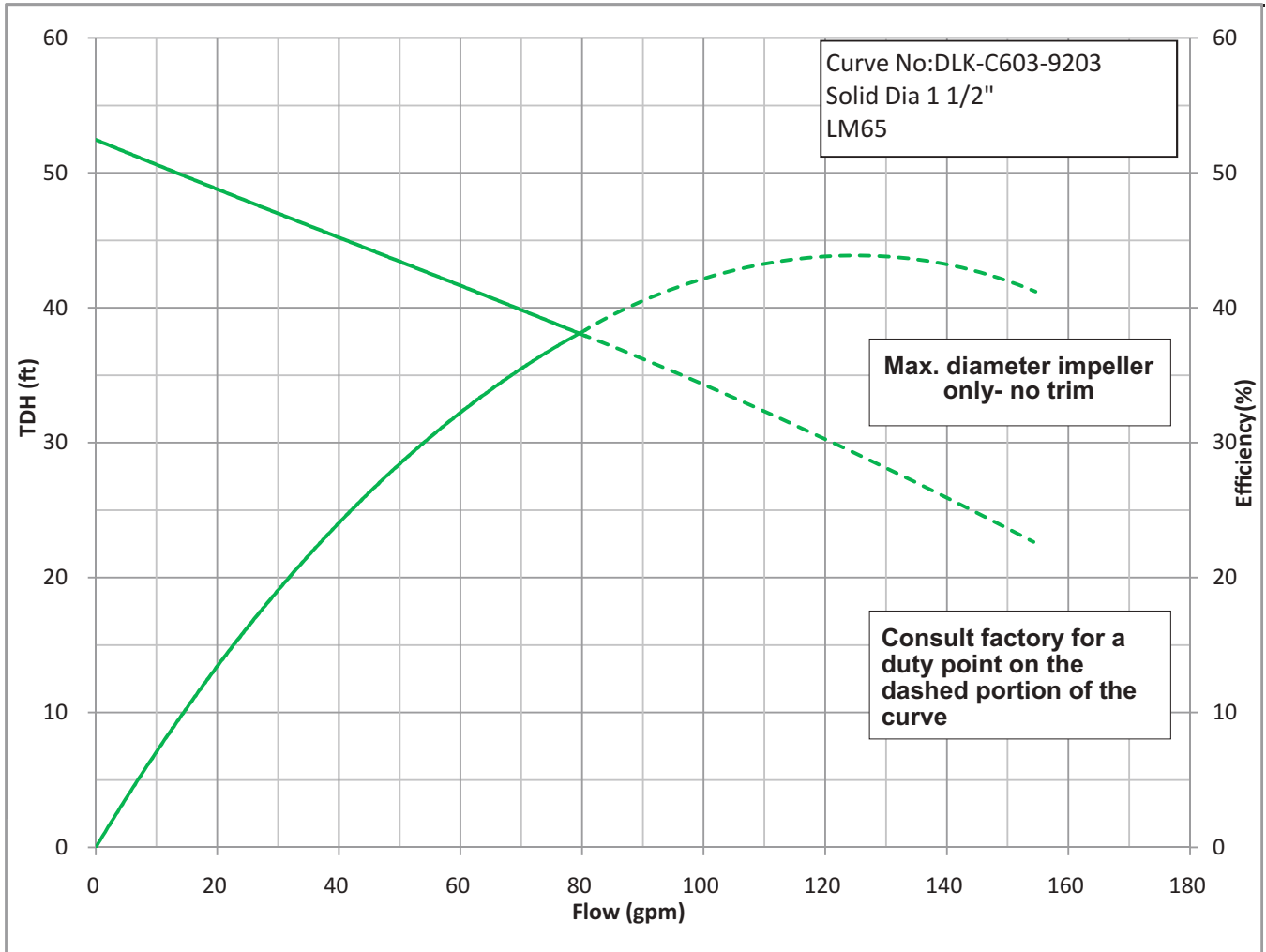

Performance Curves

Project: \_\_\_\_\_ GPM: \_\_\_\_\_ TDH: \_\_\_\_\_ EFF: \_\_\_\_\_ HP: \_\_\_\_\_ Chk'd: \_\_\_\_\_ Date: \_\_\_\_\_

80DLKFU61.5 (2HP)

Synchronous Speed 1800 RPM

2, 3 inch discharge

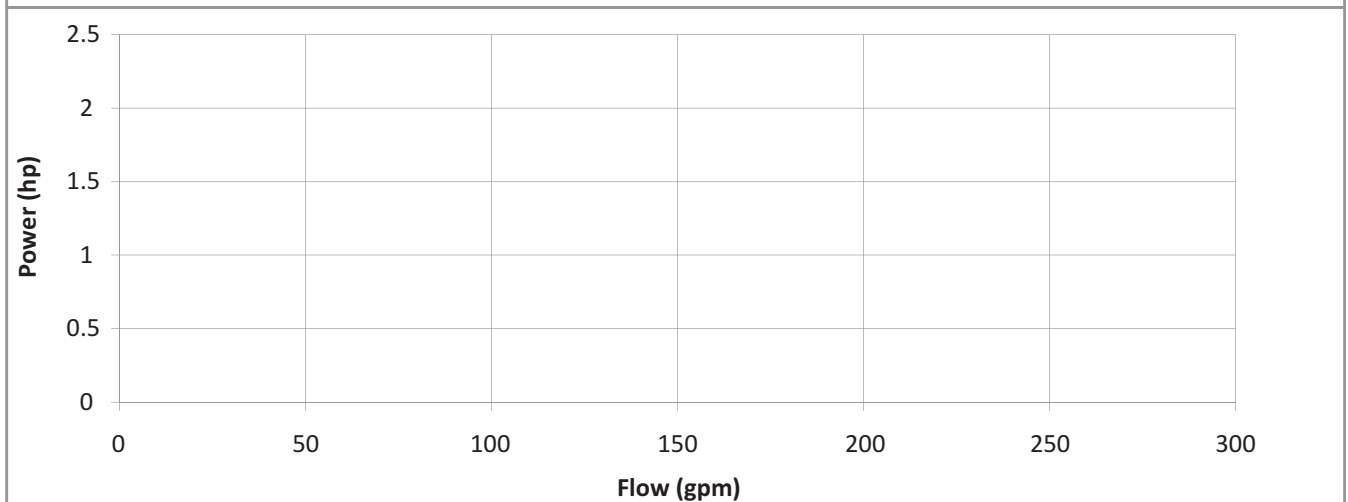
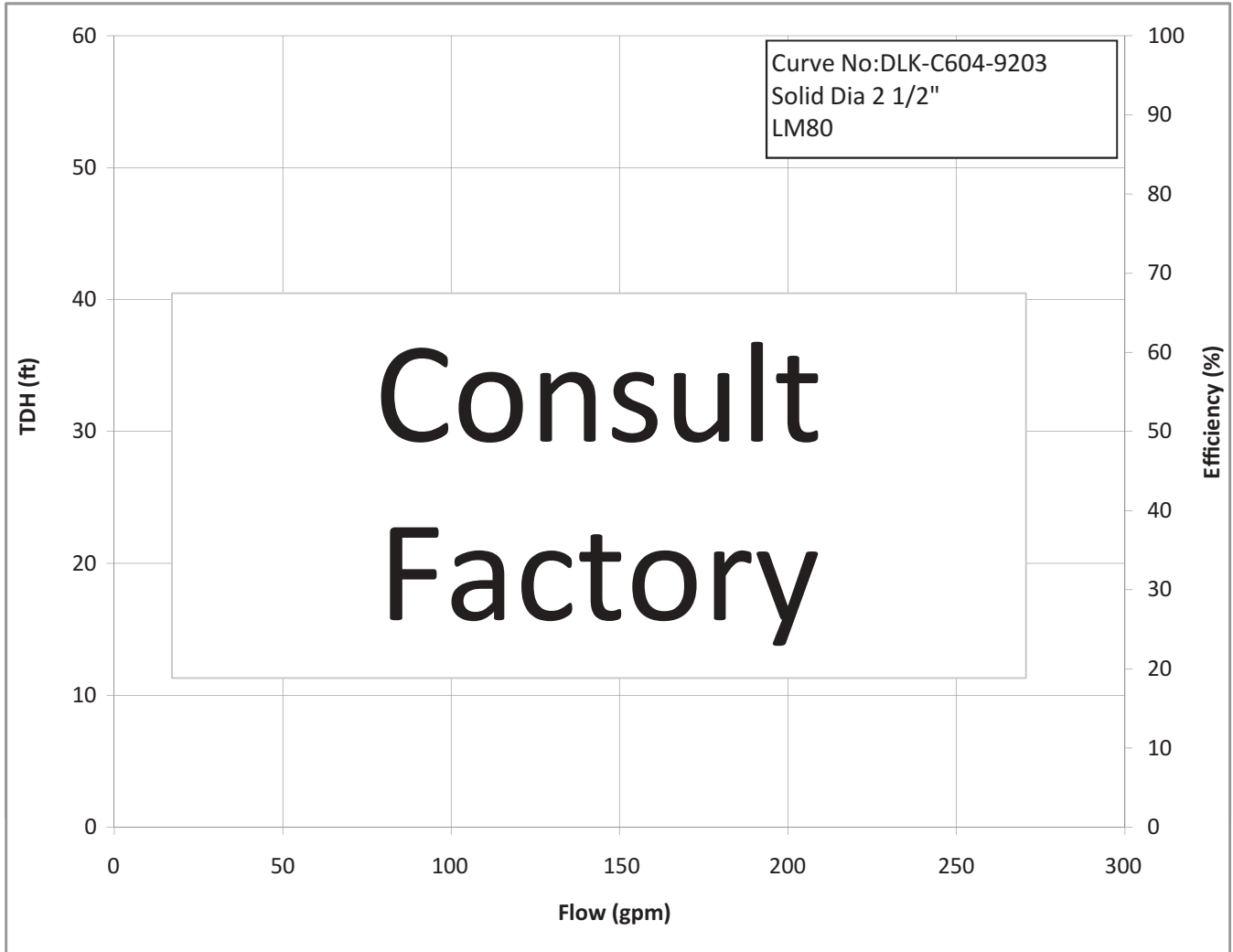

Performance Curves

Project: \_\_\_\_\_ GPM: \_\_\_\_\_ TDH: \_\_\_\_\_ EFF: \_\_\_\_\_ HP: \_\_\_\_\_ Chk'd: \_\_\_\_\_ Date: \_\_\_\_\_

80DLMKFU61.5 (2 HP)

Synchronous Speed 1800 RPM

2, 3 inch discharge

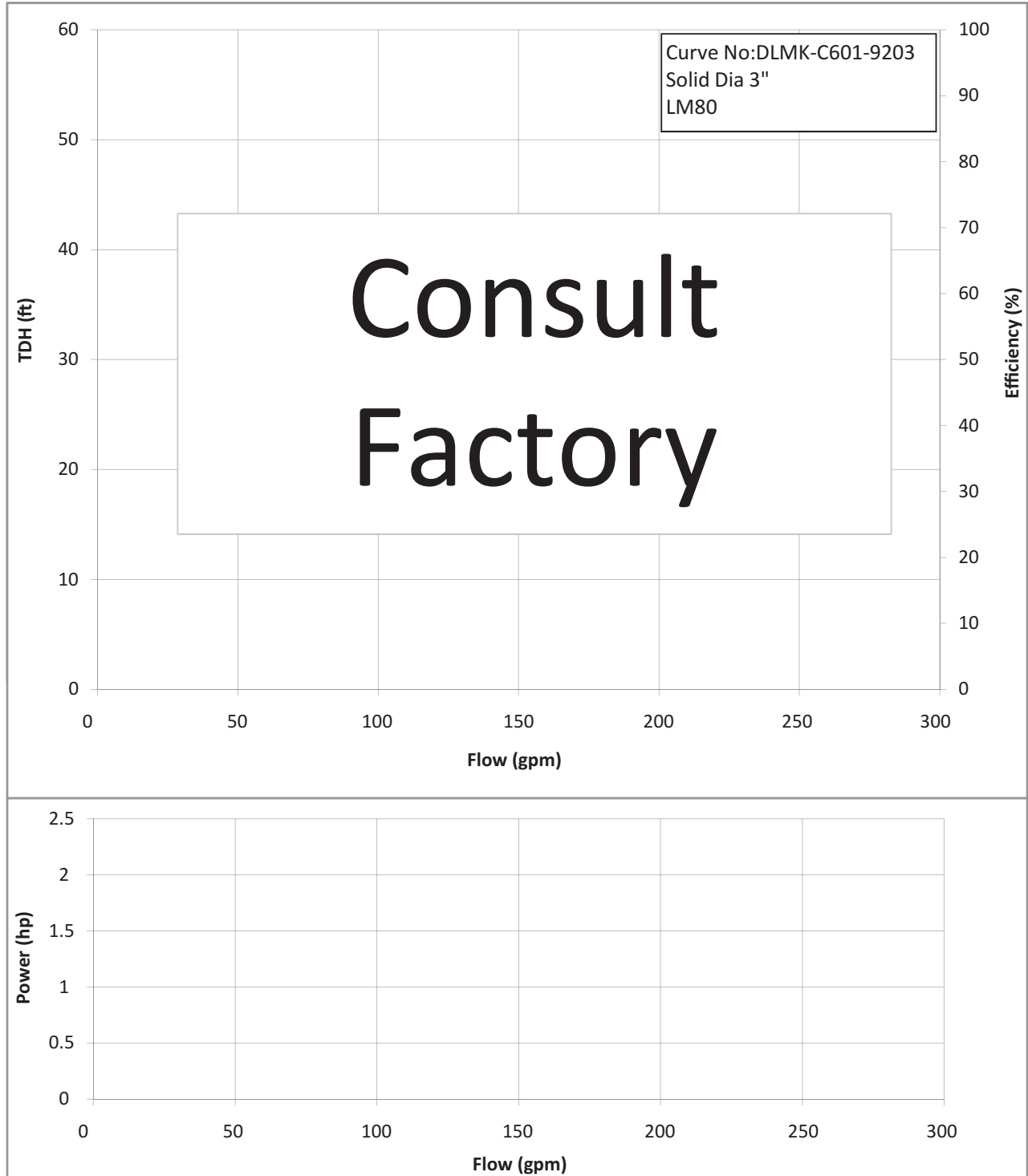

**Performance Curves**

Project: \_\_\_\_\_ GPM: \_\_\_\_\_ TDH: \_\_\_\_\_ EFF: \_\_\_\_\_ HP: \_\_\_\_\_ Chk'd: \_\_\_\_\_ Date: \_\_\_\_\_

**80DLKFU62.2 (3HP)**

**Synchronous Speed 1800 RPM**

**3, 4 inch Discharge**

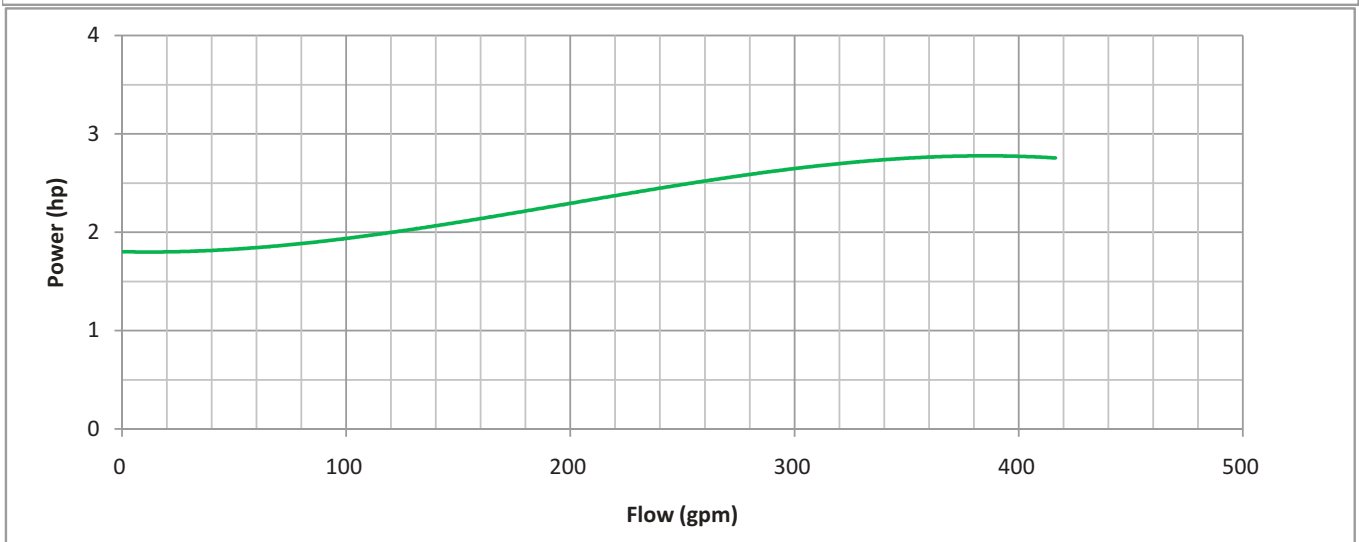
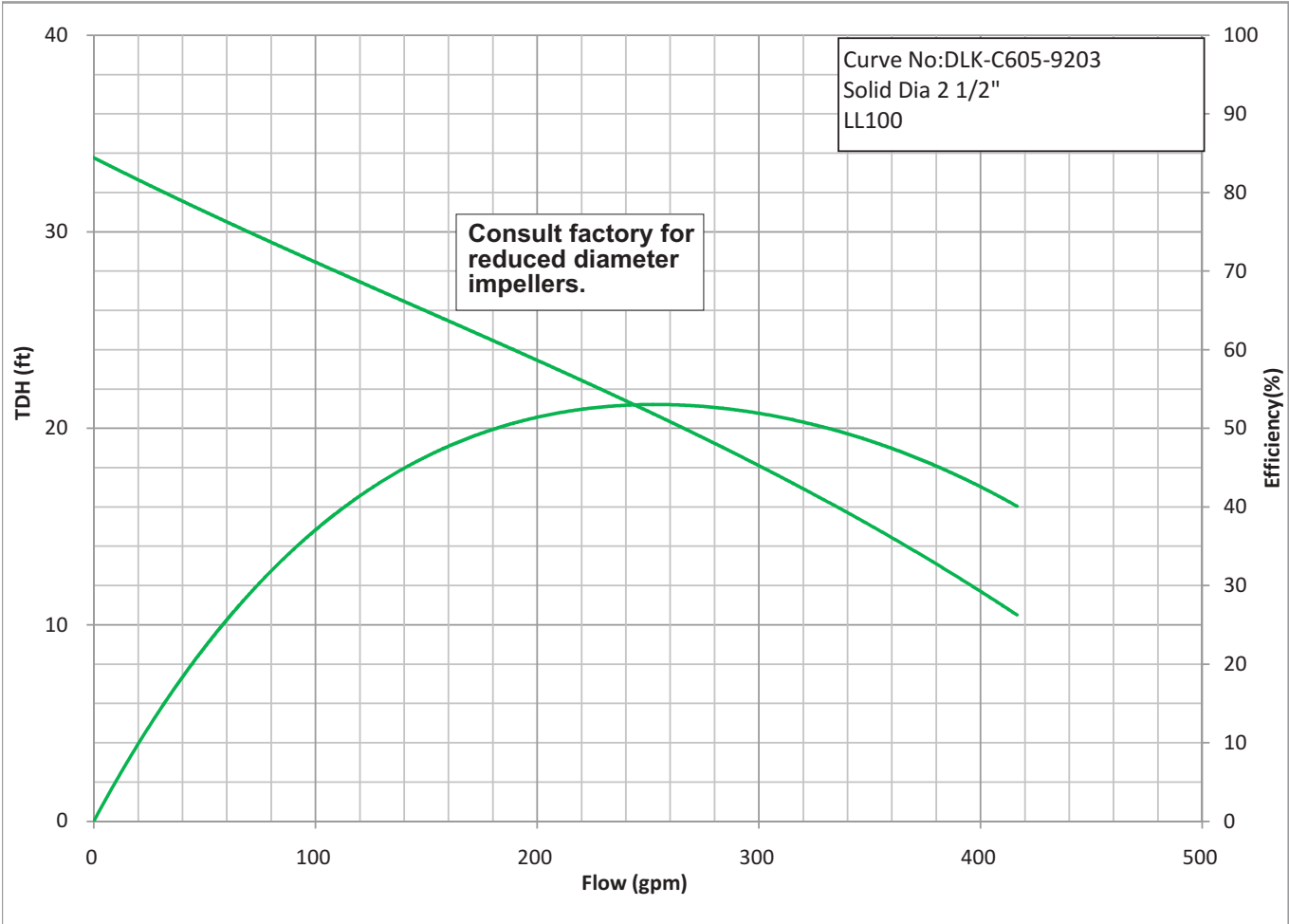



Performance Curves

Project: \_\_\_\_\_ GPM: \_\_\_\_\_ TDH: \_\_\_\_\_ EFF: \_\_\_\_\_ HP: \_\_\_\_\_ Chk'd: \_\_\_\_\_ Date: \_\_\_\_\_

80DLMKFU62.2 (3 HP)

Synchronous Speed 1800 RPM

3, 4 inch discharge

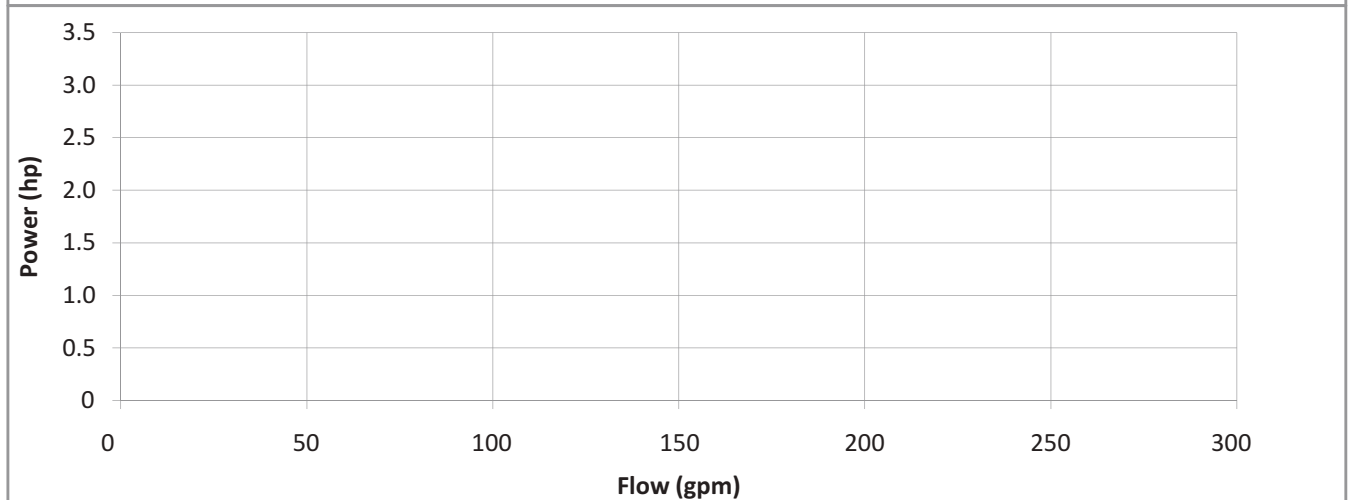
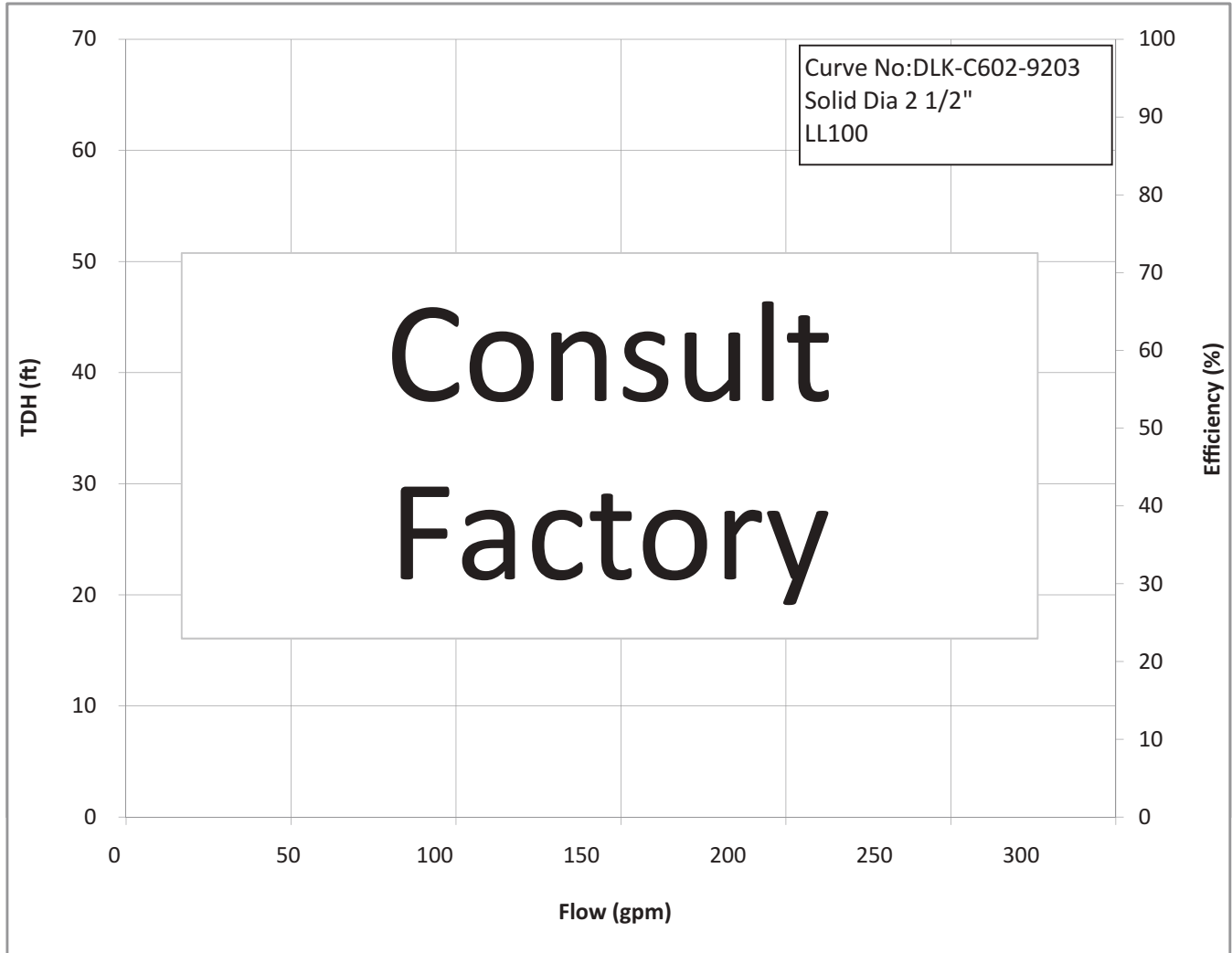

Performance Curves

Project: \_\_\_\_\_ GPM: \_\_\_\_\_ TDH: \_\_\_\_\_ EFF: \_\_\_\_\_ HP: \_\_\_\_\_ Chk'd: \_\_\_\_\_ Date: \_\_\_\_\_

80DLKFU63.7(5 HP)

Synchronous Speed 1800 RPM

3, 4 inch Discharge

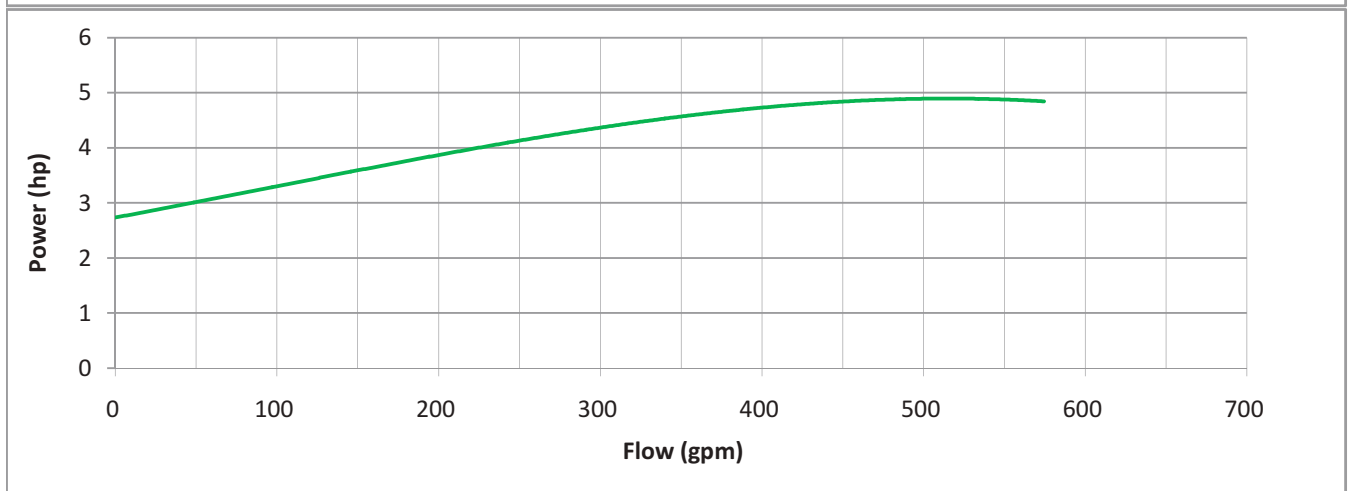
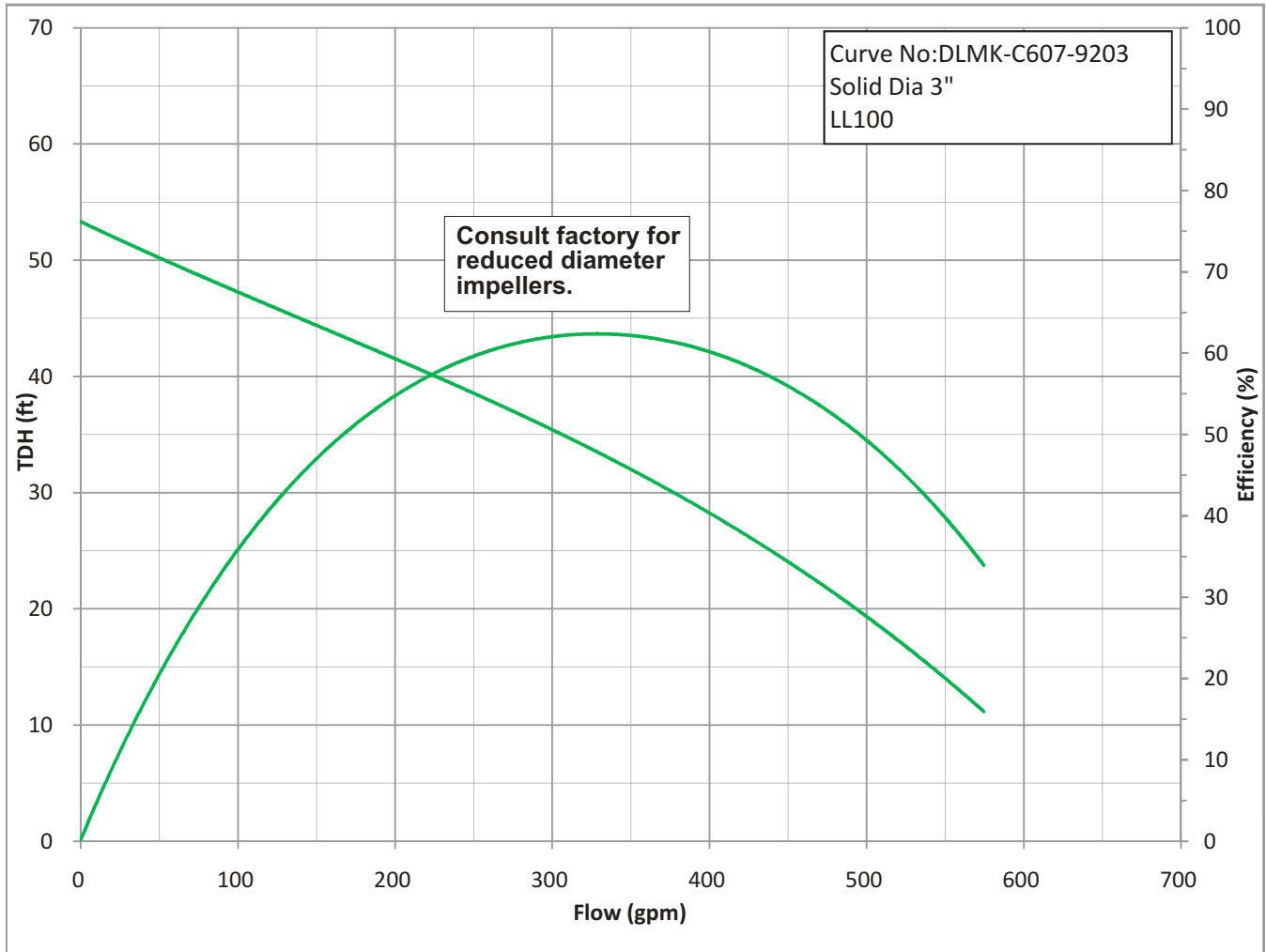

Performance Curves

Project: \_\_\_\_\_ GPM: \_\_\_\_\_ TDH: \_\_\_\_\_ EFF: \_\_\_\_\_ HP: \_\_\_\_\_ Chk'd: \_\_\_\_\_ Date: \_\_\_\_\_

80DLMKFU63.7 (5HP)

Synchronous Speed 1800 RPM

3,4 inch Discharge

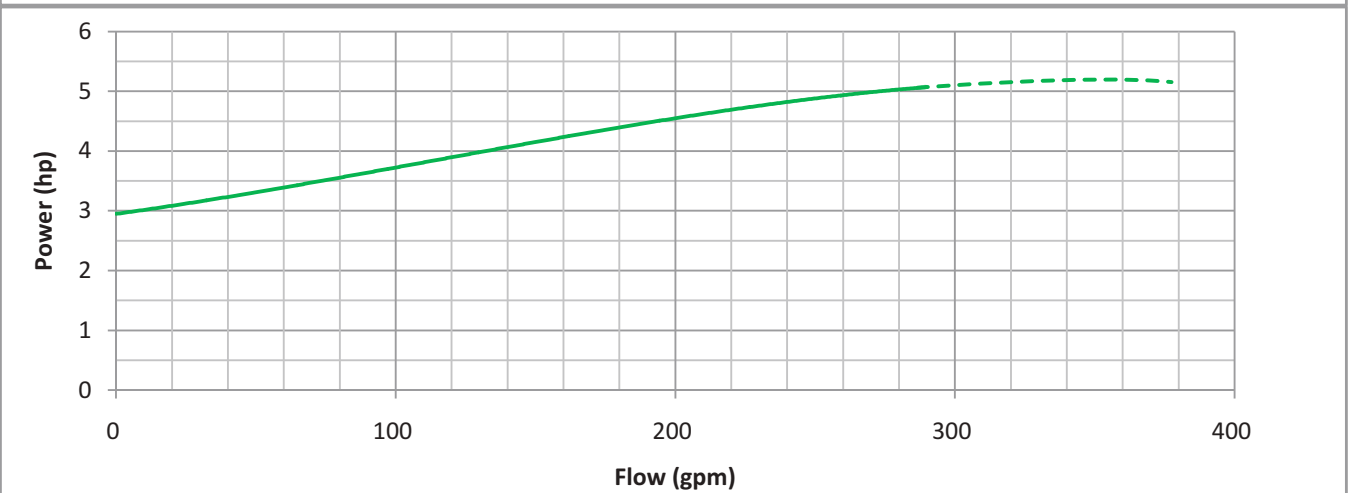
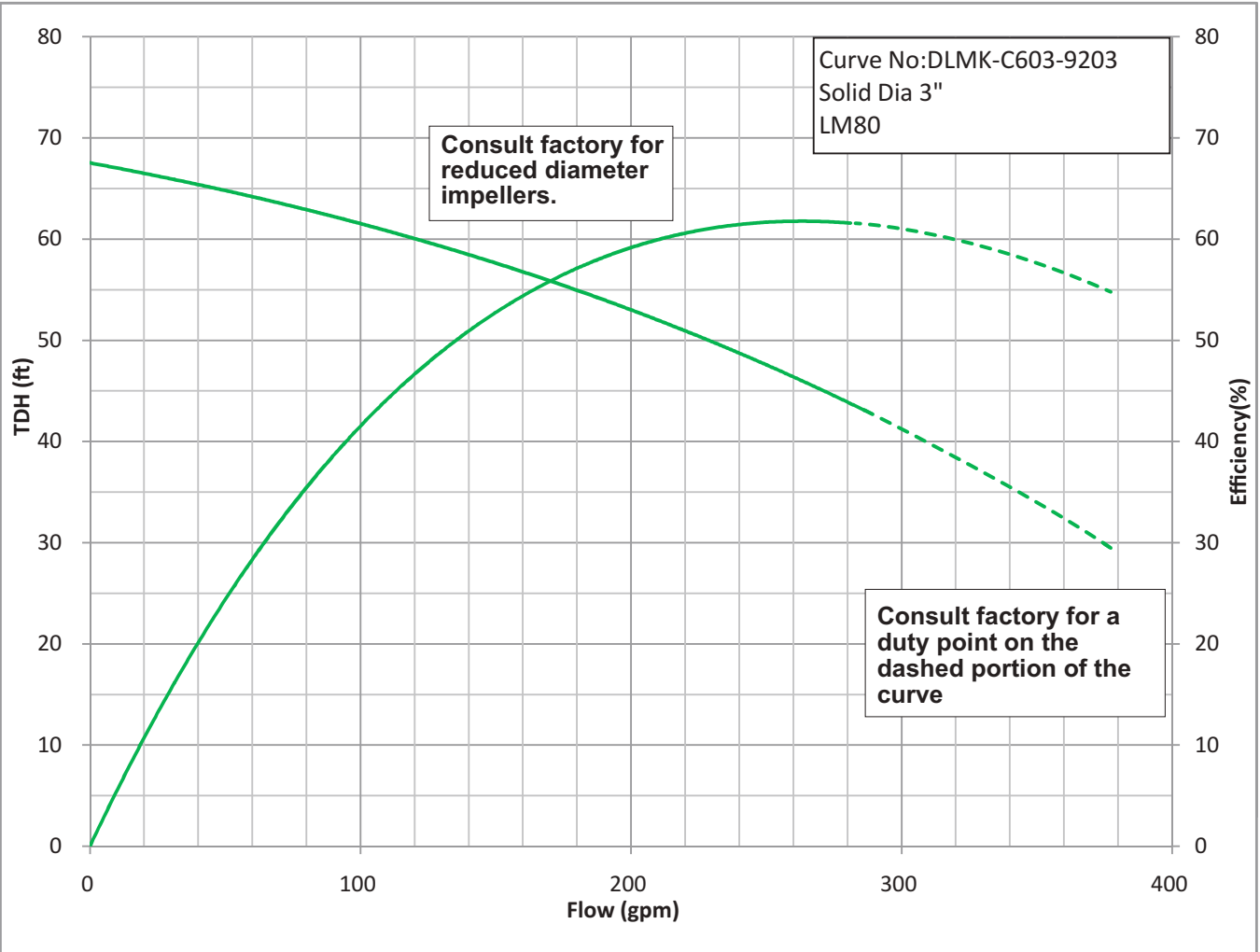

Performance Curves

Project: \_\_\_\_\_ GPM: \_\_\_\_\_ TDH: \_\_\_\_\_ EFF: \_\_\_\_\_ HP: \_\_\_\_\_ Chk'd: \_\_\_\_\_ Date: \_\_\_\_\_

80DLKFU65.5 (7.5 HP)

Synchronous Speed 1800 RPM

3,4 inch Discharge

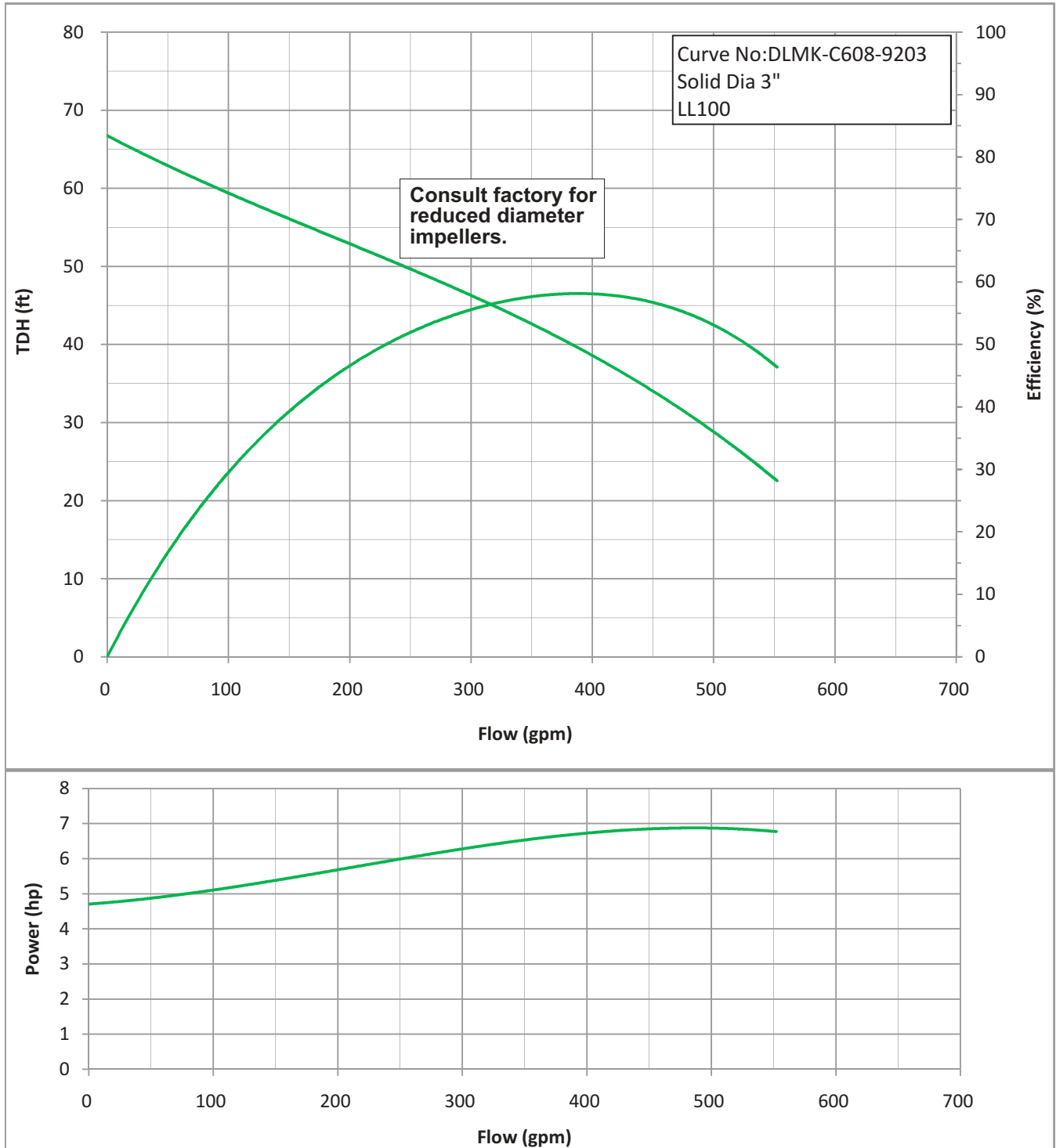

**Performance Curves**

Project: \_\_\_\_\_ GPM: \_\_\_\_\_ TDH: \_\_\_\_\_ EFF: \_\_\_\_\_ HP: \_\_\_\_\_ Chk'd: \_\_\_\_\_ Date: \_\_\_\_\_

**80DLMKFU65.5 (7.5 HP)**

**Synchronous Speed 1800 RPM**

**3,4 inch Discharge**

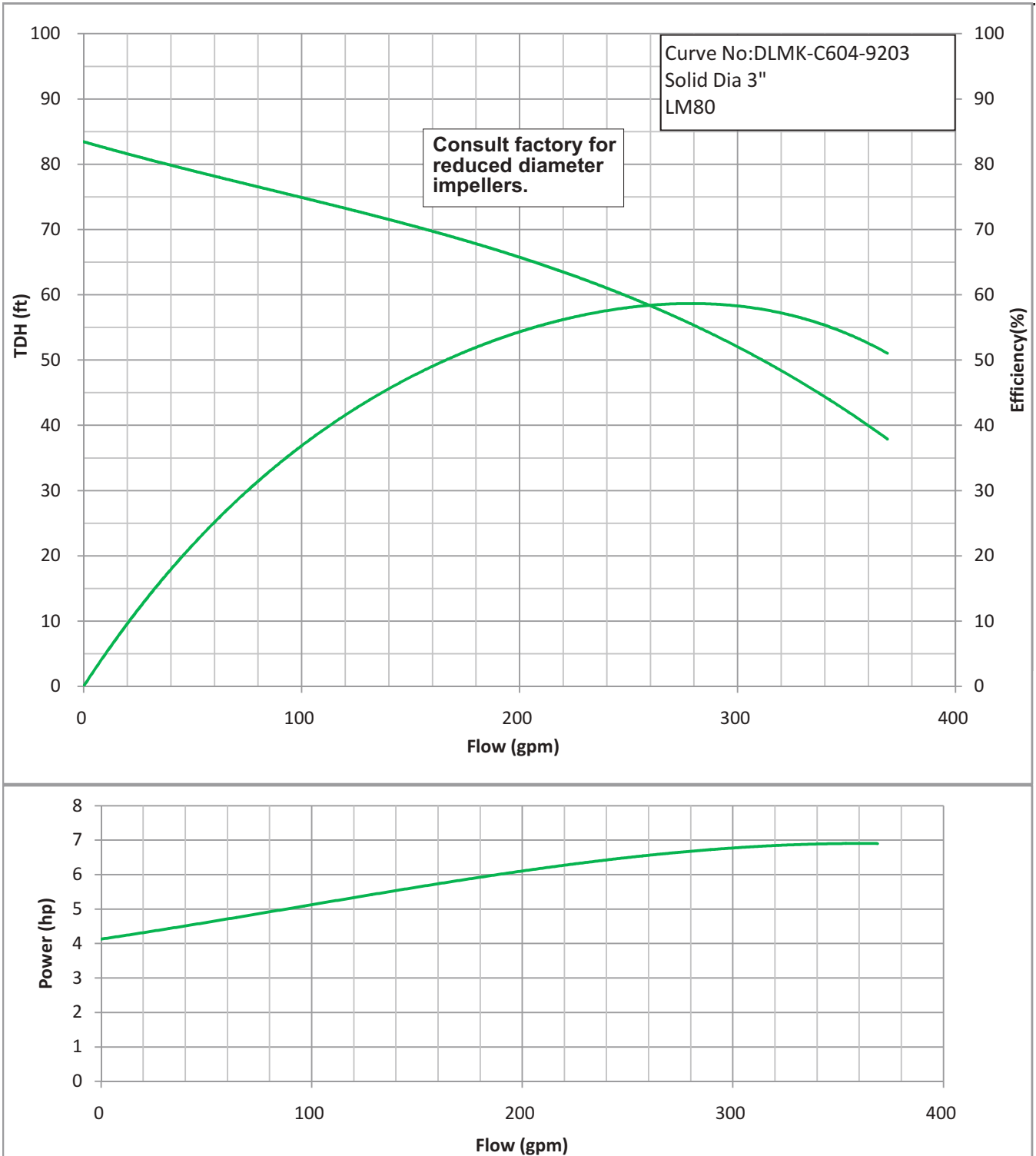

Performance Curves

Project: \_\_\_\_\_ GPM: \_\_\_\_\_ TDH: \_\_\_\_\_ EFF: \_\_\_\_\_ HP: \_\_\_\_\_ Chk'd: \_\_\_\_\_ Date: \_\_\_\_\_

80DLKFU67.5 (10 HP)

Synchronous Speed 1800 RPM

3,4 inch Discharge

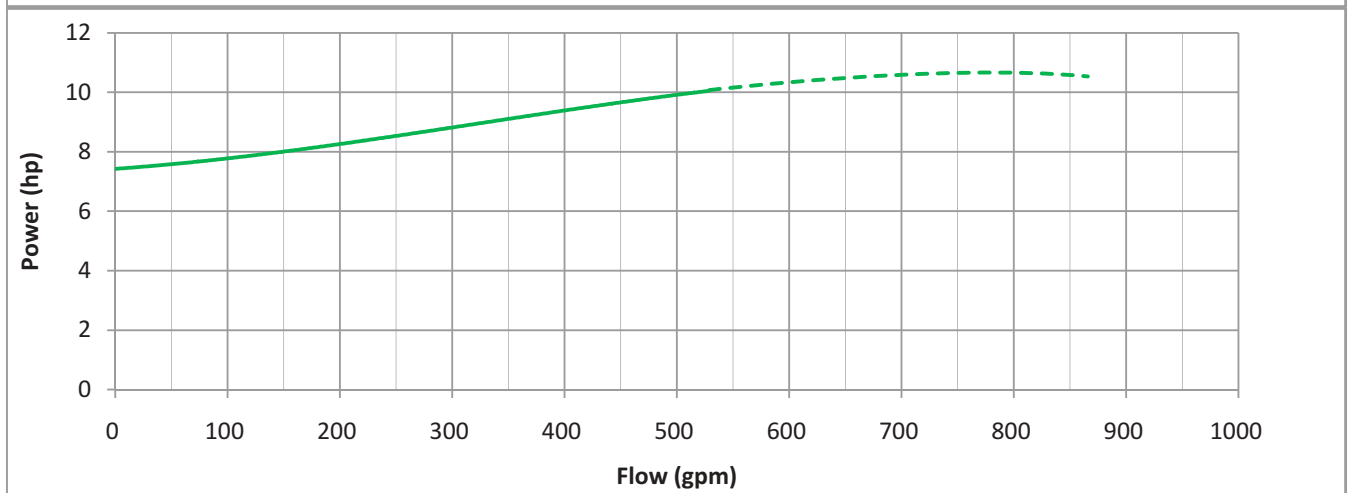
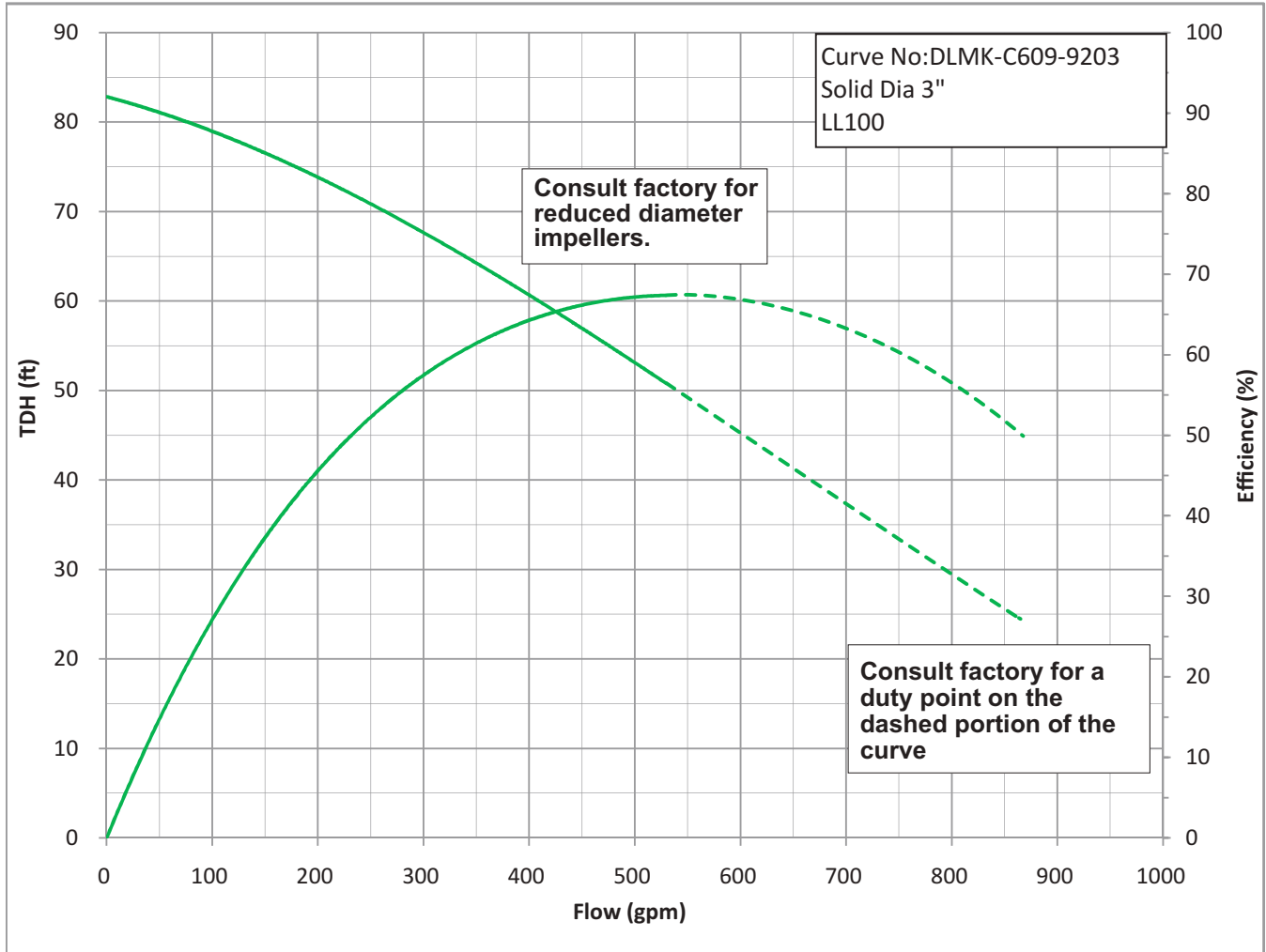

Performance Curves

Project: \_\_\_\_\_ GPM: \_\_\_\_\_ TDH: \_\_\_\_\_ EFF: \_\_\_\_\_ HP: \_\_\_\_\_ Chk'd: \_\_\_\_\_ Date: \_\_\_\_\_

80DLCMKFU67.5 (10 HP)

Synchronous Speed 1800 RPM

3, 4 inch discharge

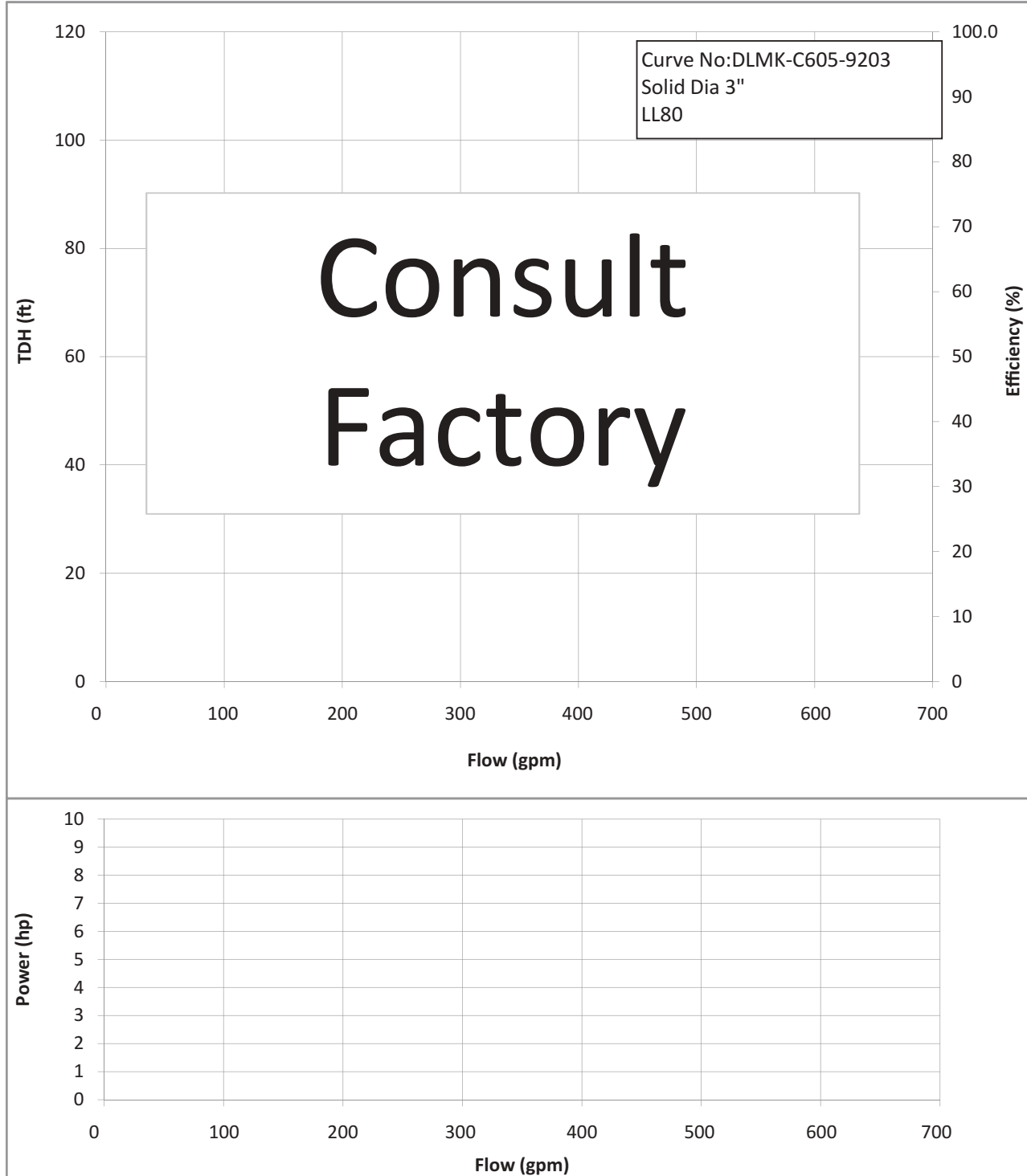

Performance Curves

Project: \_\_\_\_\_ GPM: \_\_\_\_\_ TDH: \_\_\_\_\_ EFF: \_\_\_\_\_ HP: \_\_\_\_\_ Chk'd: \_\_\_\_\_ Date: \_\_\_\_\_

80DLKFU611 (15 HP)

Synchronous Speed 1800 RPM

3,4 inch Discharge

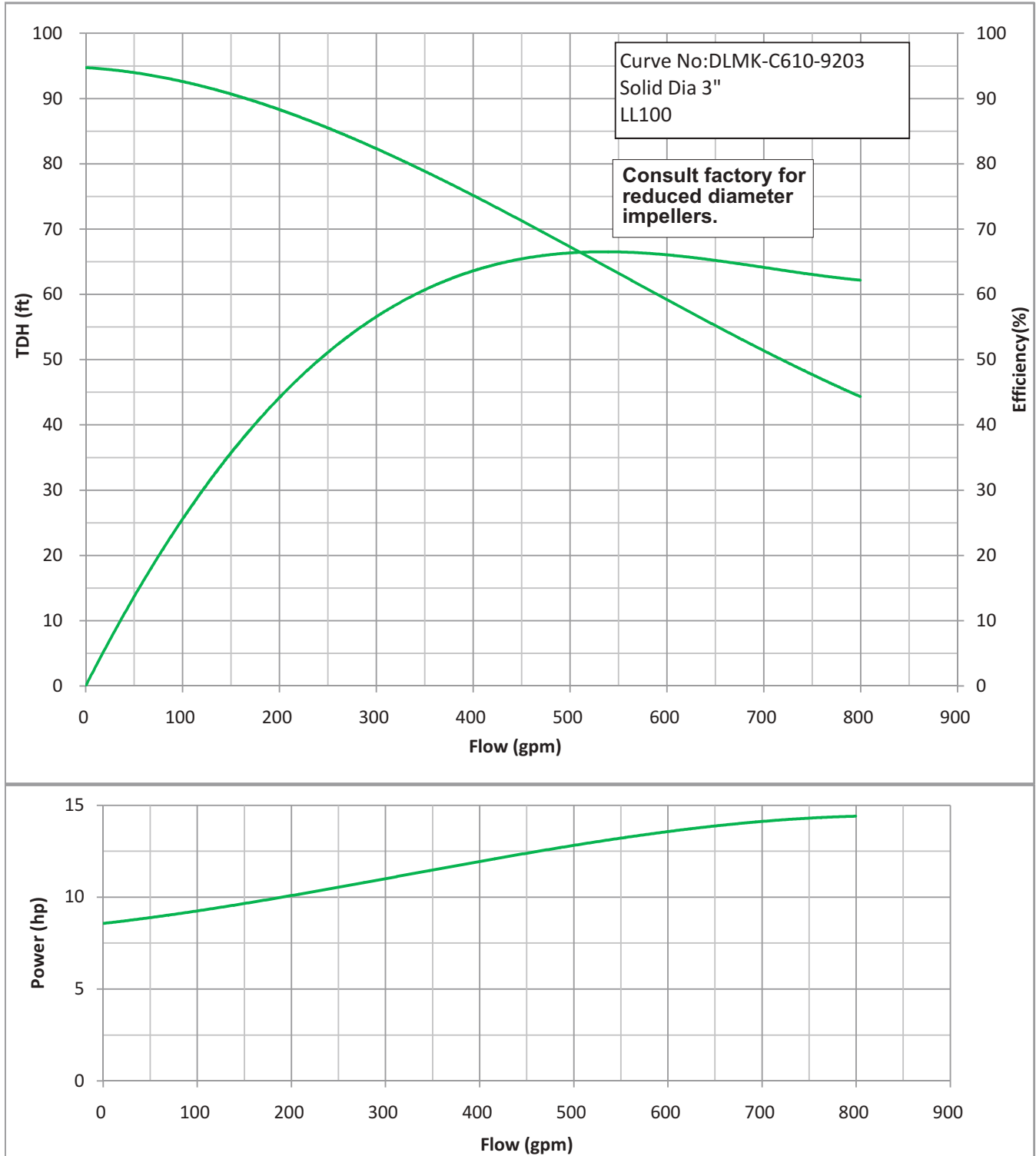



Performance Curves

Project: \_\_\_\_\_ GPM: \_\_\_\_\_ TDH: \_\_\_\_\_ EFF: \_\_\_\_\_ HP: \_\_\_\_\_ Chk'd: \_\_\_\_\_ Date: \_\_\_\_\_

80DLCMKFU611 (15 HP)

Synchronous Speed 1800 RPM

3,4 inch Discharge

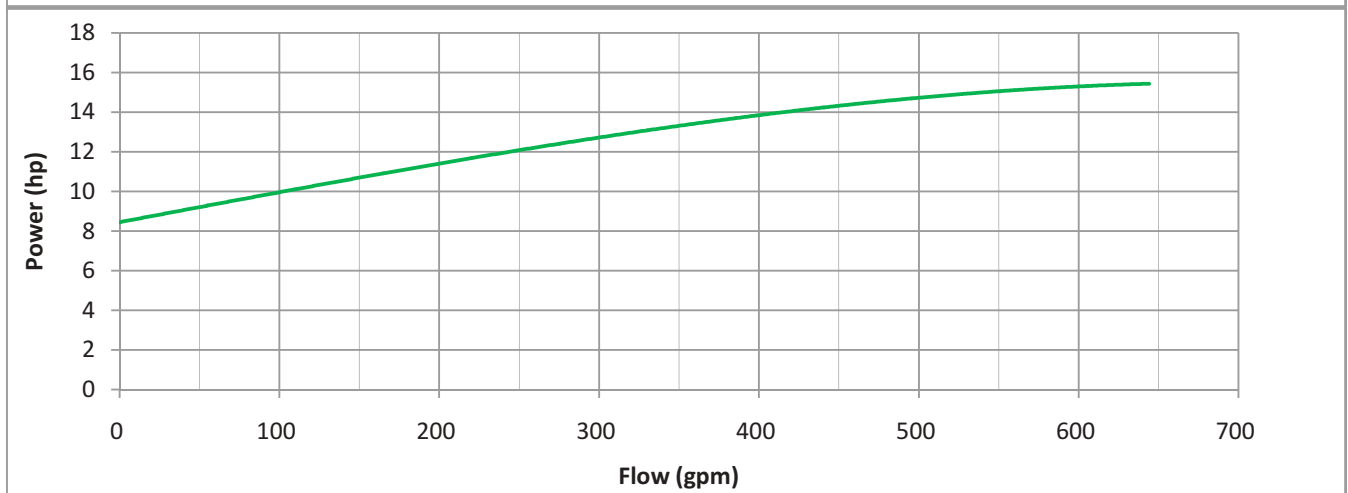
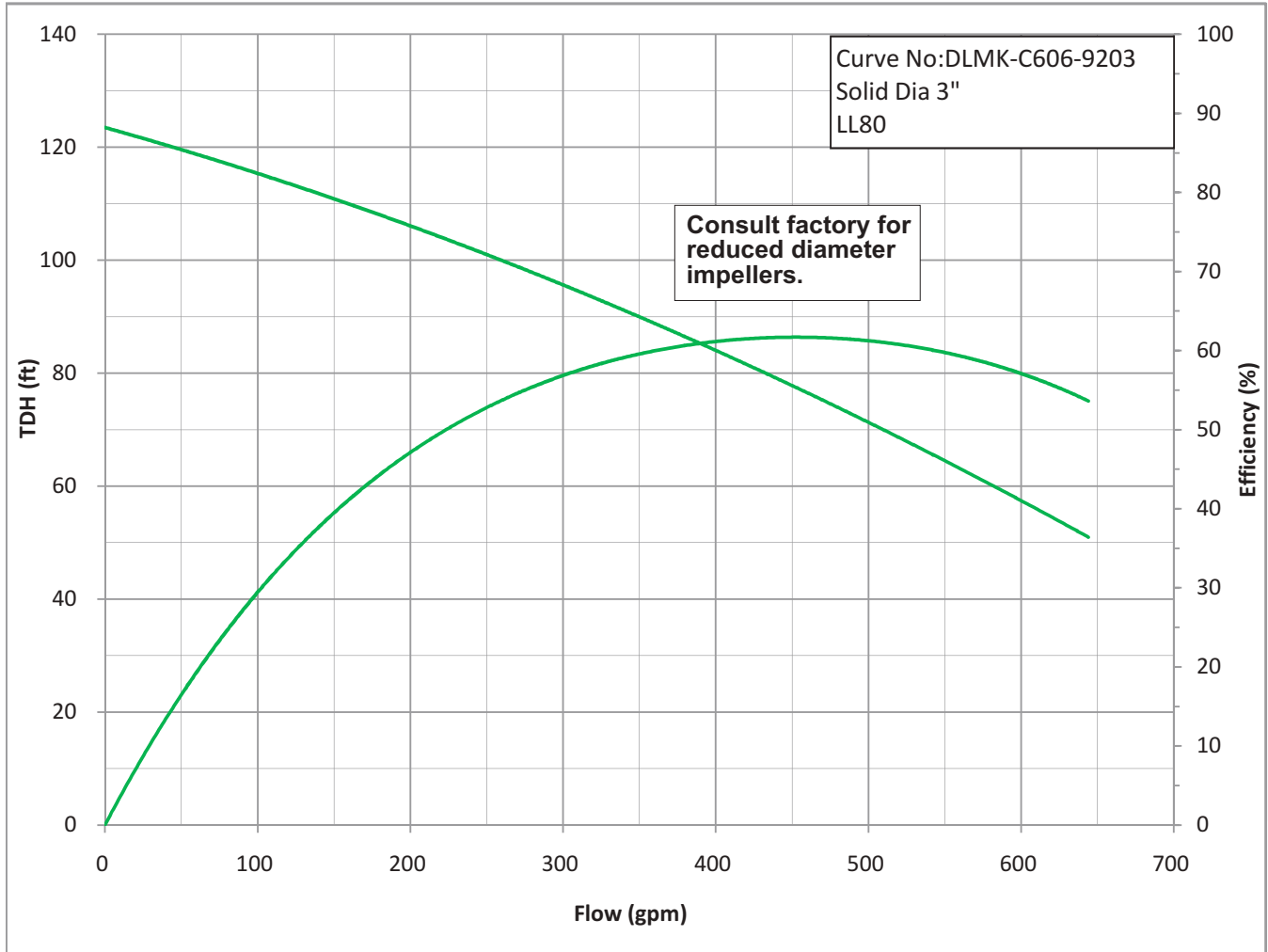

**Performance Curves**

Project: \_\_\_\_\_ GPM: \_\_\_\_\_ TDH: \_\_\_\_\_ EFF: \_\_\_\_\_ HP: \_\_\_\_\_ Chk'd: \_\_\_\_\_ Date: \_\_\_\_\_

**80DLKFU615 (20 HP)**

**Synchronous Speed 1800 RPM**

**3,4 inch Discharge**

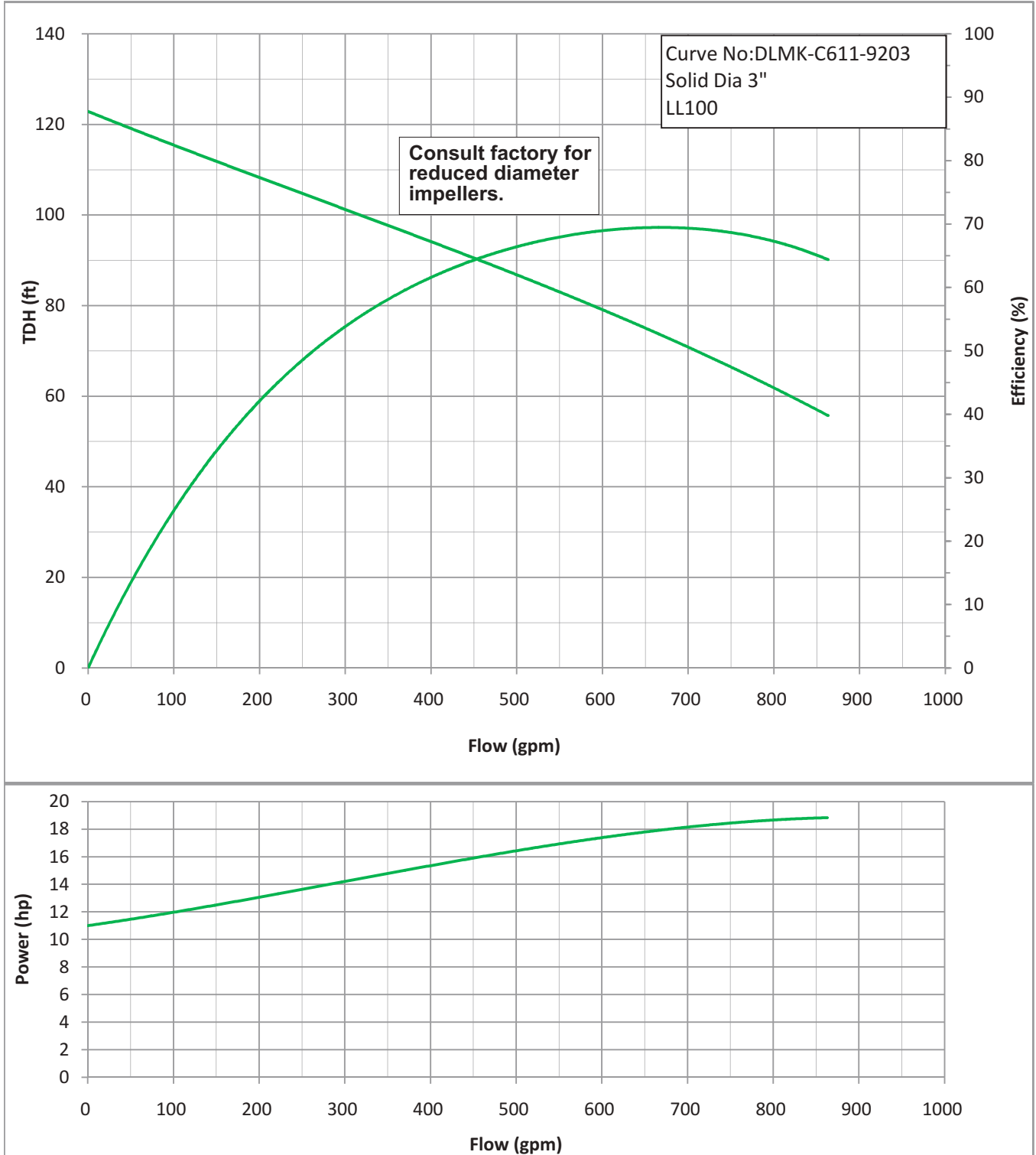

Performance Curves

Project: \_\_\_\_\_ GPM: \_\_\_\_\_ TDH: \_\_\_\_\_ EFF: \_\_\_\_\_ HP: \_\_\_\_\_ Chk'd: \_\_\_\_\_ Date: \_\_\_\_\_

80DLKFU618 (25 HP)

Synchronous Speed 1800 RPM

3,4 inch Discharge

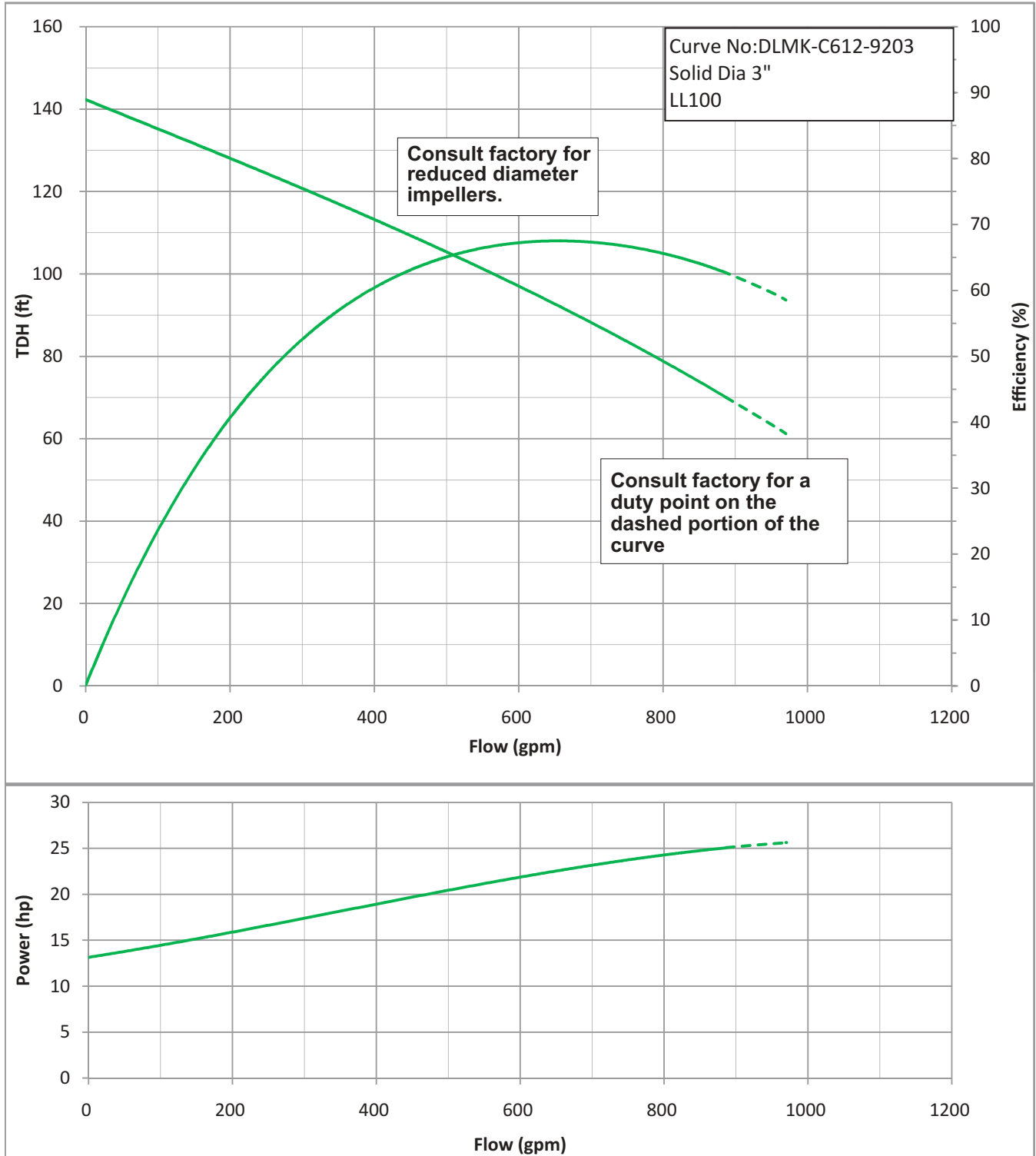

Performance Curves

Project: \_\_\_\_\_ GPM: \_\_\_\_\_ TDH: \_\_\_\_\_ EFF: \_\_\_\_\_ HP: \_\_\_\_\_ Chk'd: \_\_\_\_\_ Date: \_\_\_\_\_

80DLKFU622 (30 HP)

Synchronous Speed 1800 RPM

3,4 inch Discharge

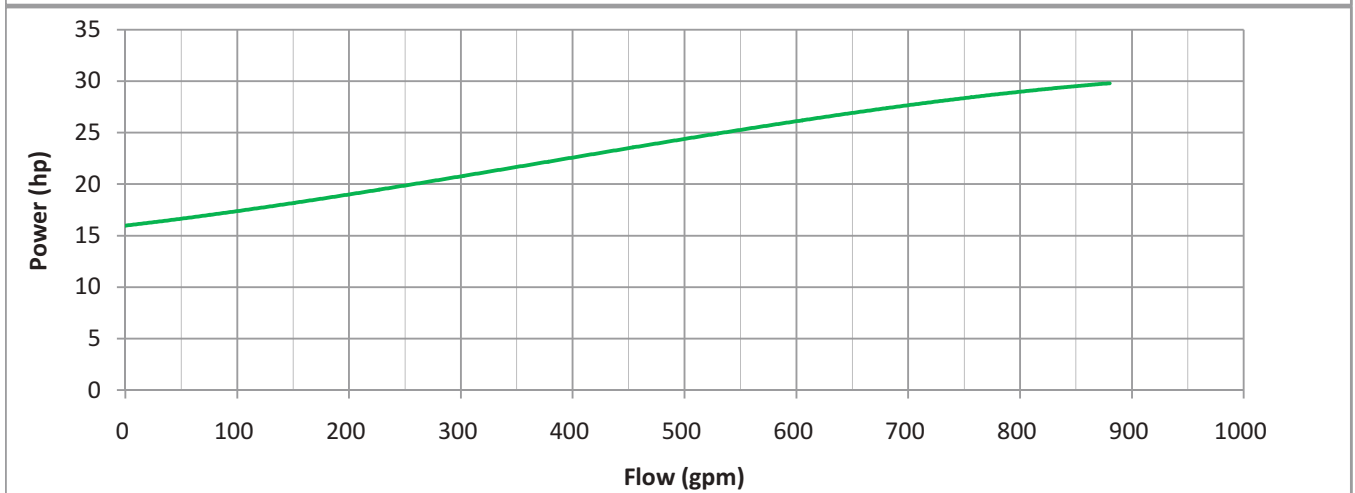
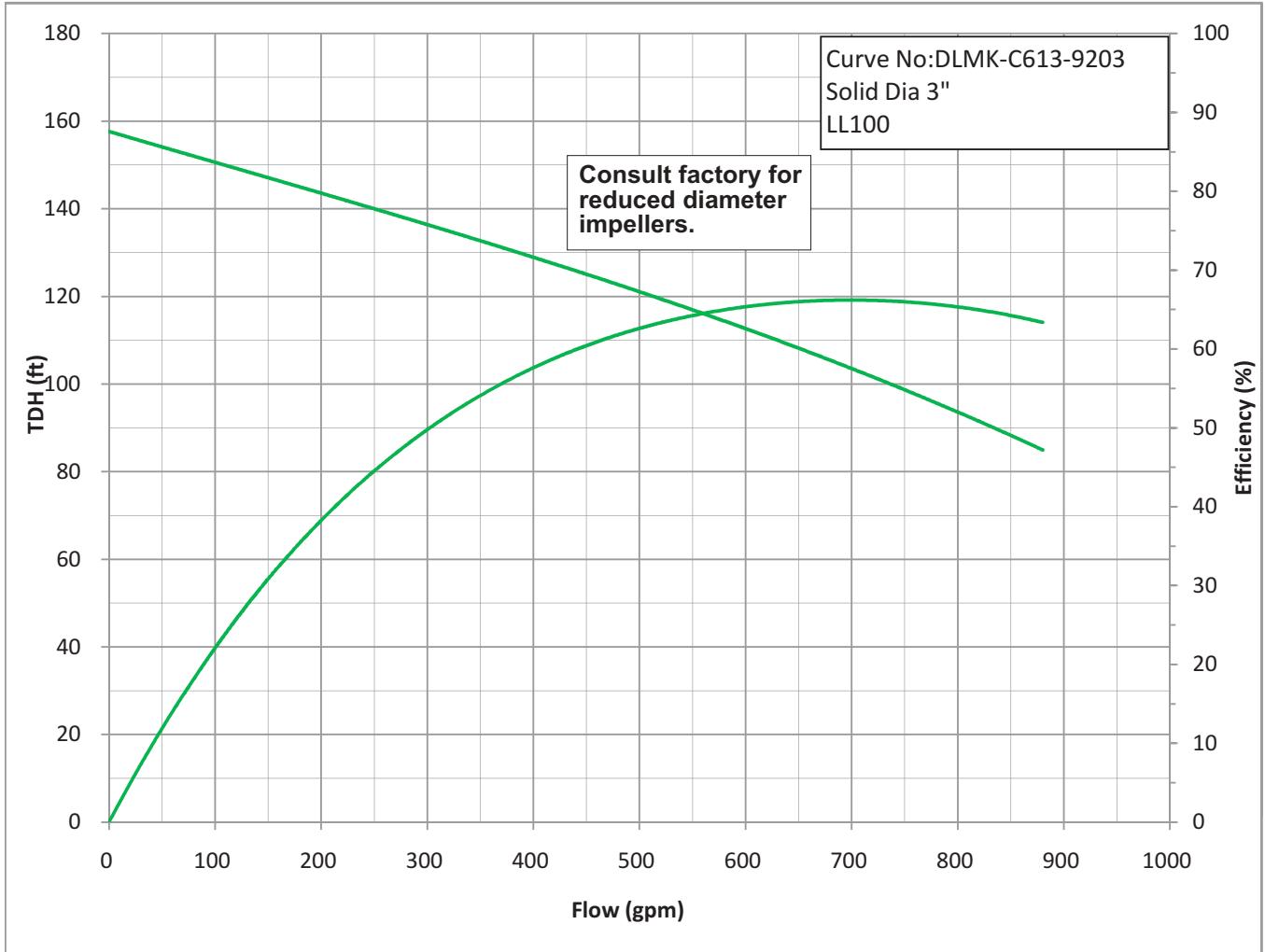

Performance Curves

Project: \_\_\_\_\_ GPM: \_\_\_\_\_ TDH: \_\_\_\_\_ EFF: \_\_\_\_\_ HP: \_\_\_\_\_ Chk'd: \_\_\_\_\_ Date: \_\_\_\_\_

100DLKFU61.5 (2 HP)

Synchronous Speed 1800 RPM

3, 4 inch Discharge

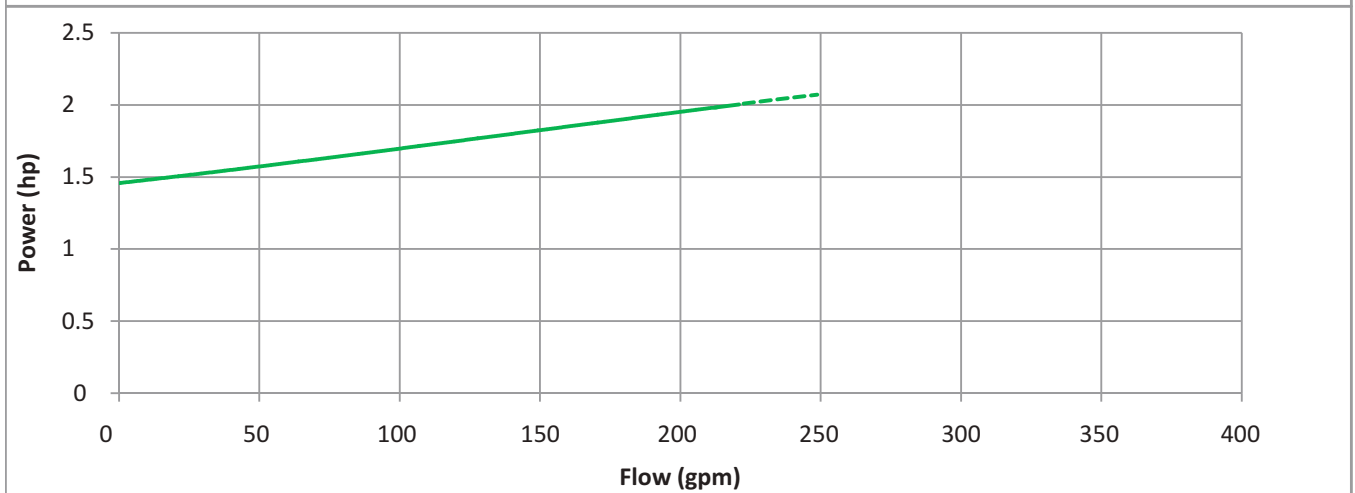
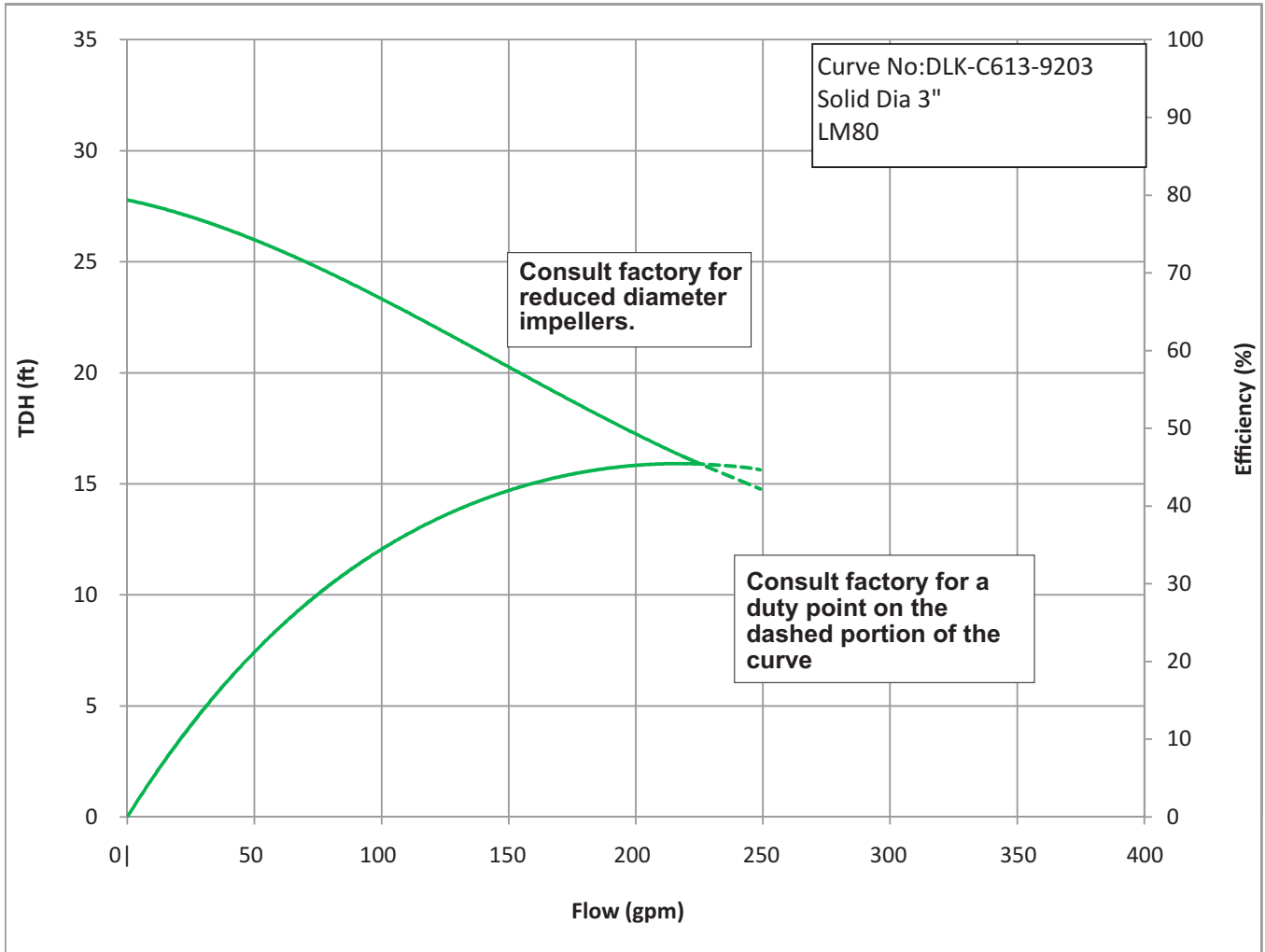

Performance Curves

Project: \_\_\_\_\_ GPM: \_\_\_\_\_ TDH: \_\_\_\_\_ EFF: \_\_\_\_\_ HP: \_\_\_\_\_ Chk'd: \_\_\_\_\_ Date: \_\_\_\_\_

100DLKFU62.2 ( 3 HP)

Synchronous Speed 1800 RPM

3, 4 inch Discharge

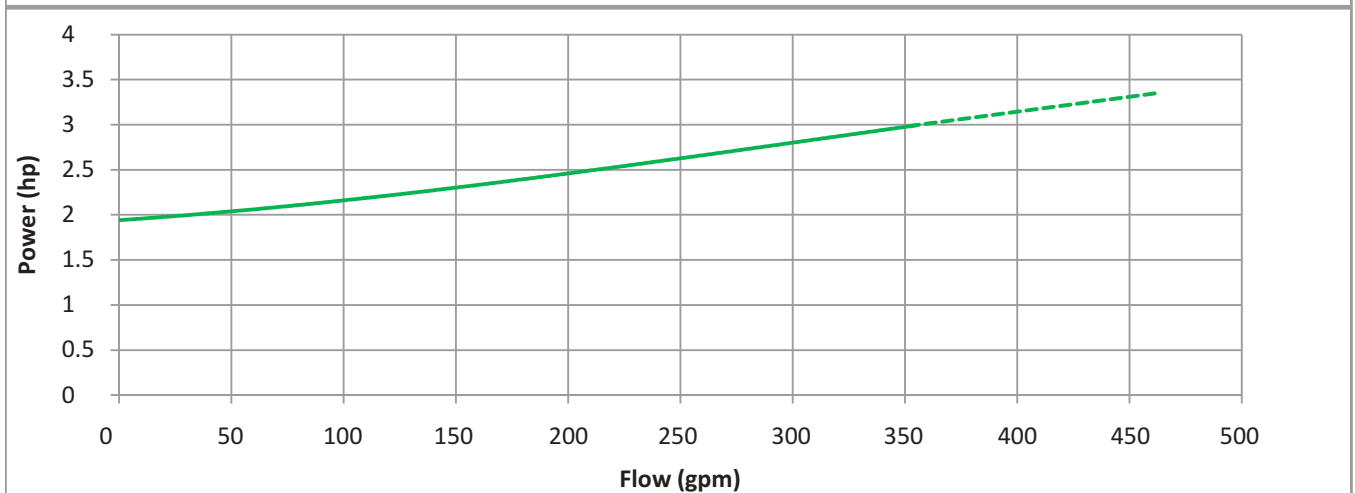
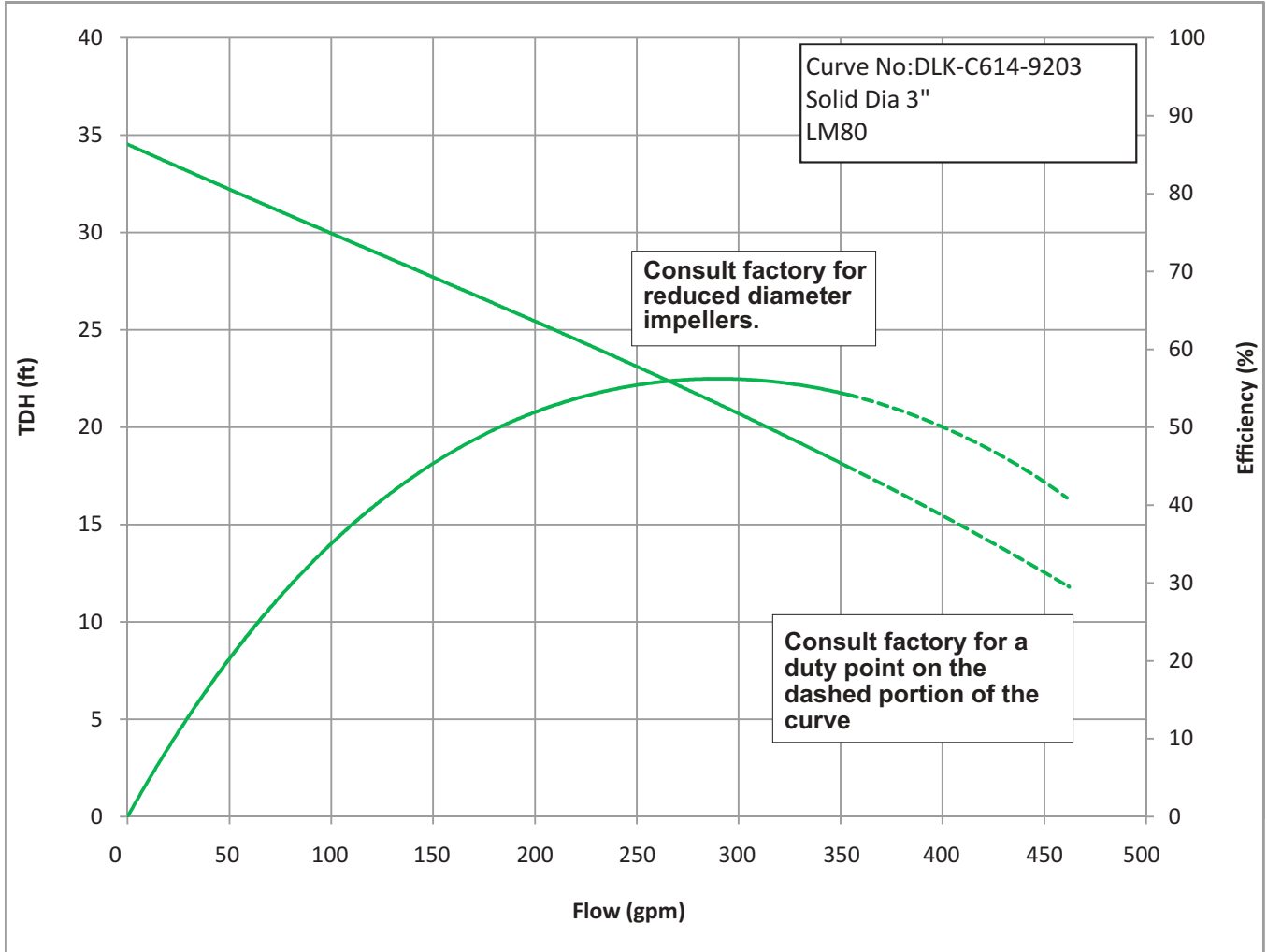

Performance Curves

Project: \_\_\_\_\_ GPM: \_\_\_\_\_ TDH: \_\_\_\_\_ EFF: \_\_\_\_\_ HP: \_\_\_\_\_ Chk'd: \_\_\_\_\_ Date: \_\_\_\_\_

100DLMKFU62.2 (3HP)

Synchronous Speed 1800 RPM

3,4 inch Discharge

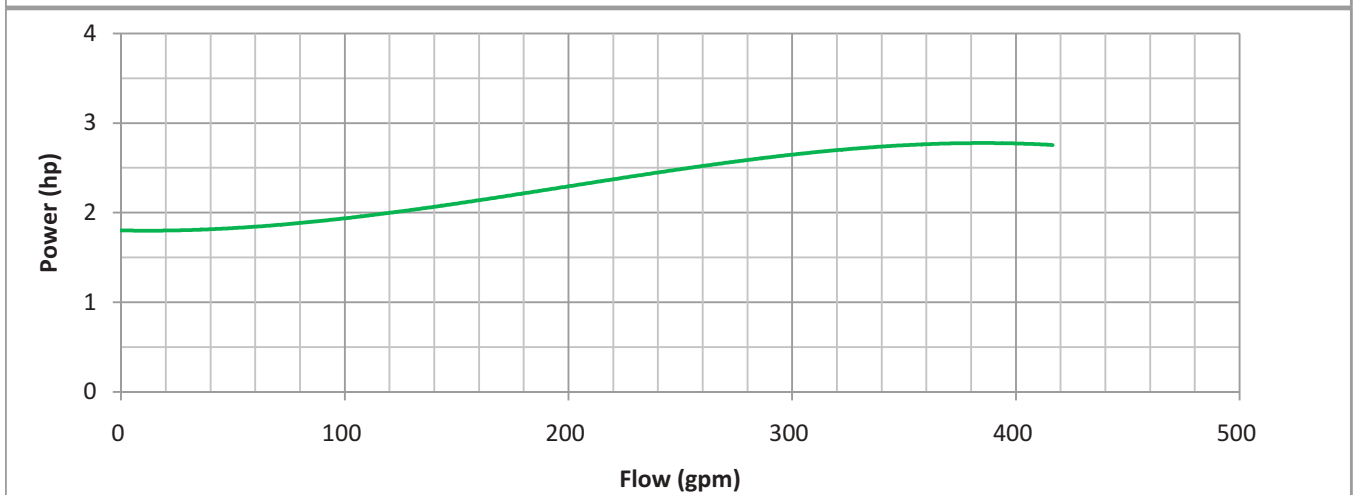
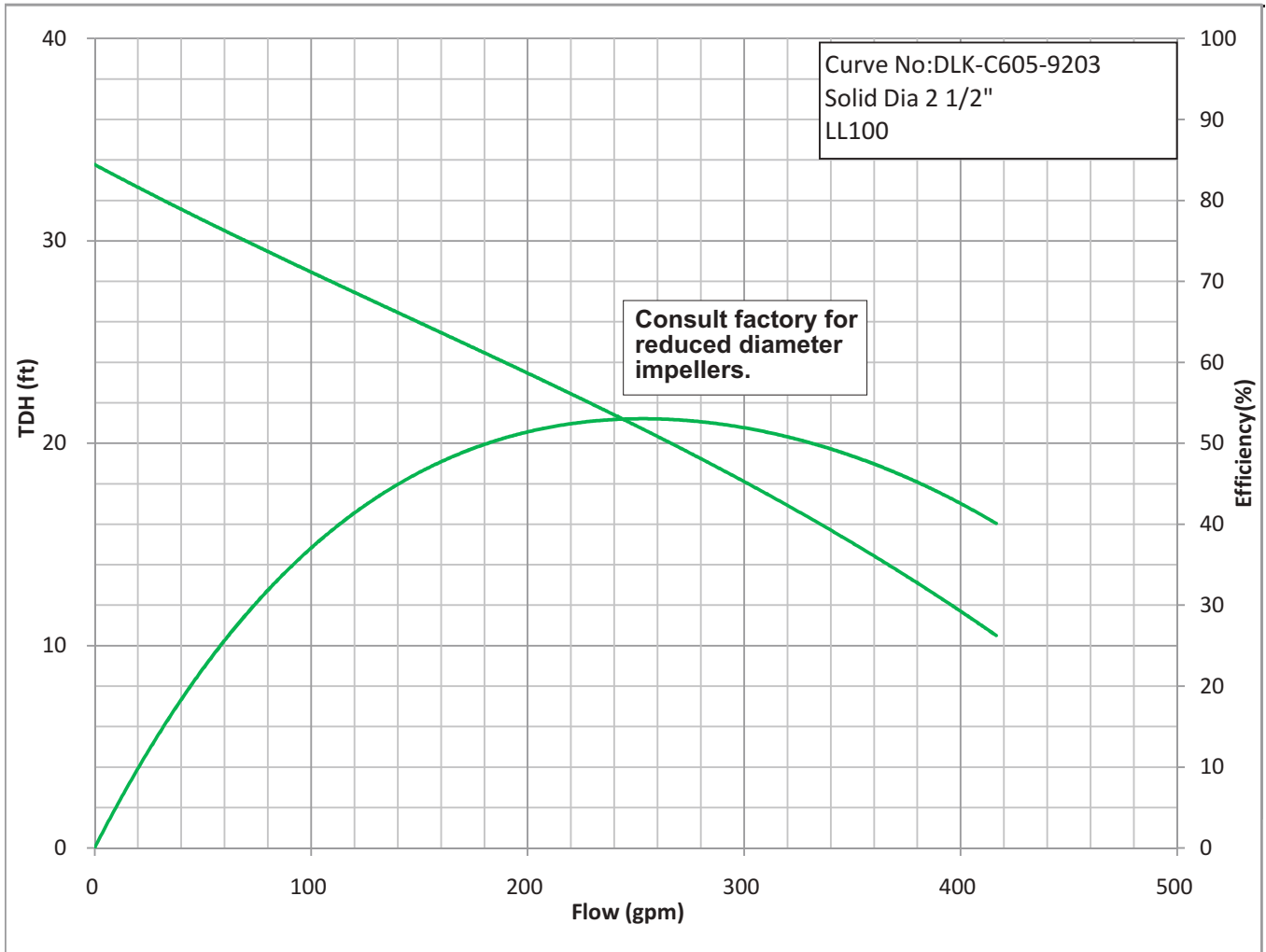

Performance Curves

Project: \_\_\_\_\_ GPM: \_\_\_\_\_ TDH: \_\_\_\_\_ EFF: \_\_\_\_\_ HP: \_\_\_\_\_ Chk'd: \_\_\_\_\_ Date: \_\_\_\_\_

100DLKFU63.7 ( 5 HP)

Synchronous Speed 1800 RPM

3, 4 inch Discharge

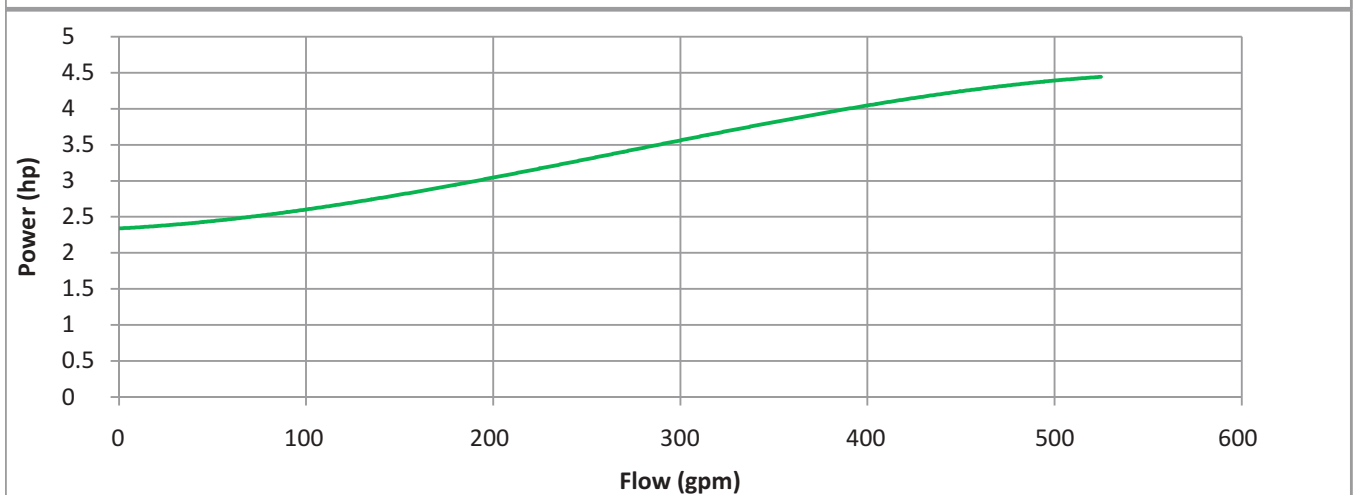
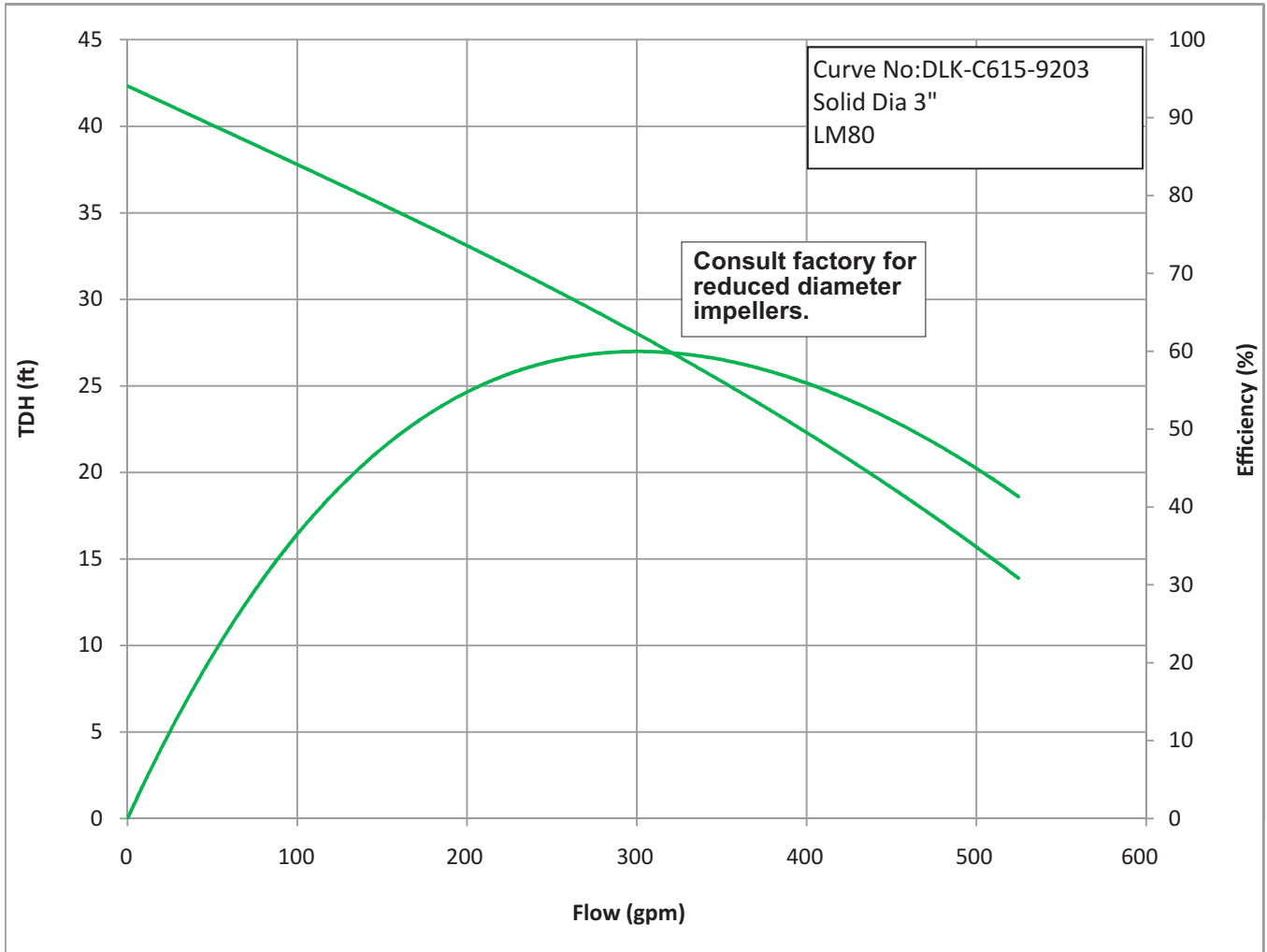



Performance Curves

Project: \_\_\_\_\_ GPM: \_\_\_\_\_ TDH: \_\_\_\_\_ EFF: \_\_\_\_\_ HP: \_\_\_\_\_ Chk'd: \_\_\_\_\_ Date: \_\_\_\_\_

100DLMKFU63.7 (5 HP)

Synchronous Speed 1800 RPM

3, 4 inch discharge

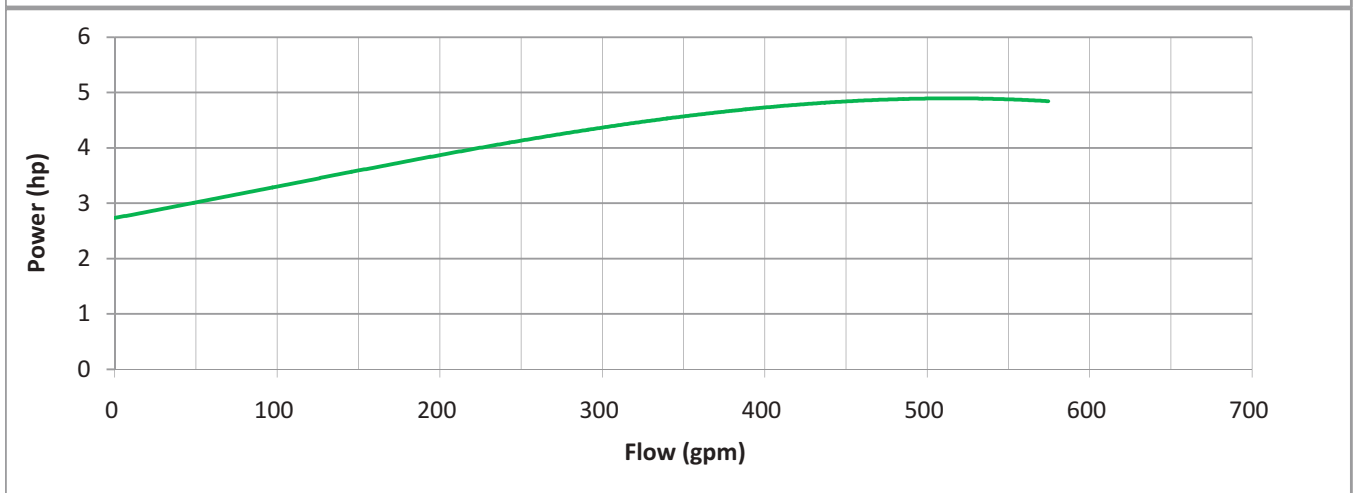
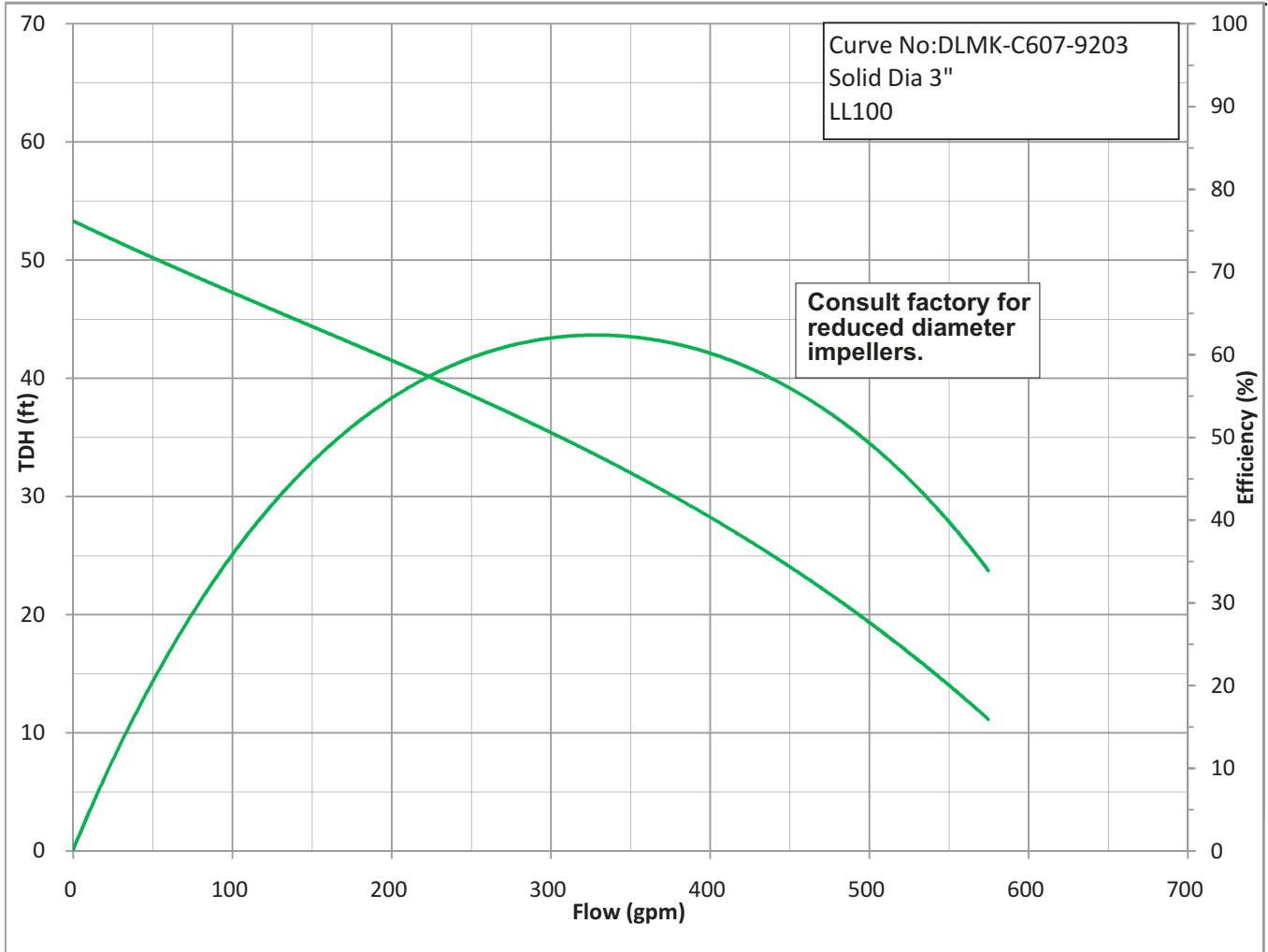

**Performance Curves**

Project: \_\_\_\_\_ GPM: \_\_\_\_\_ TDH: \_\_\_\_\_ EFF: \_\_\_\_\_ HP: \_\_\_\_\_ Chk'd: \_\_\_\_\_ Date: \_\_\_\_\_

**100DLKFU65.5 (7.5 HP)**

**Synchronous Speed 1800 RPM**

**4, 6 inch discharge**

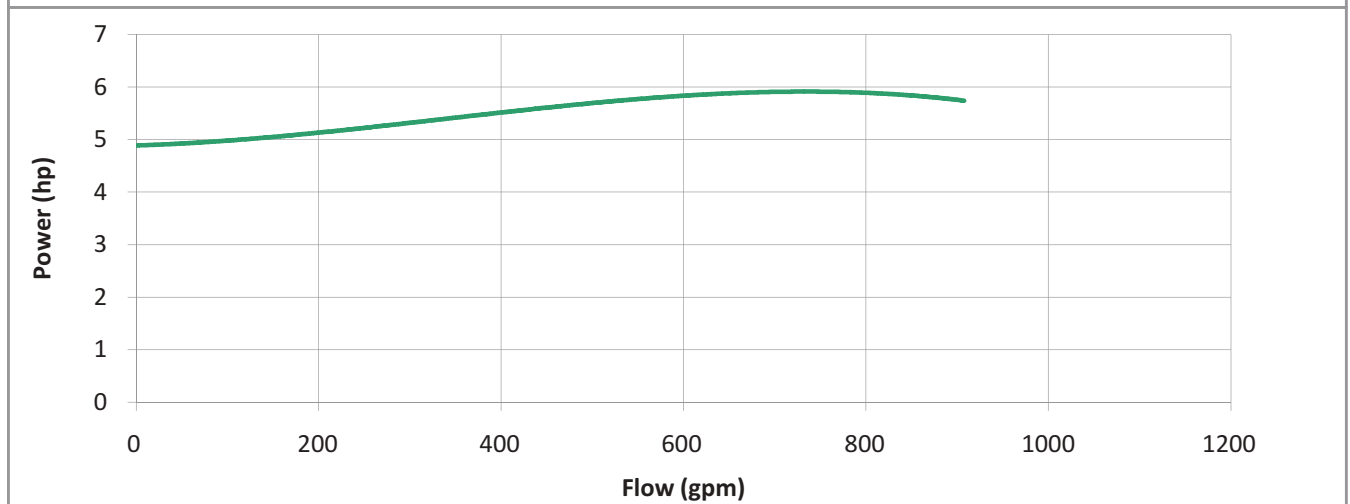
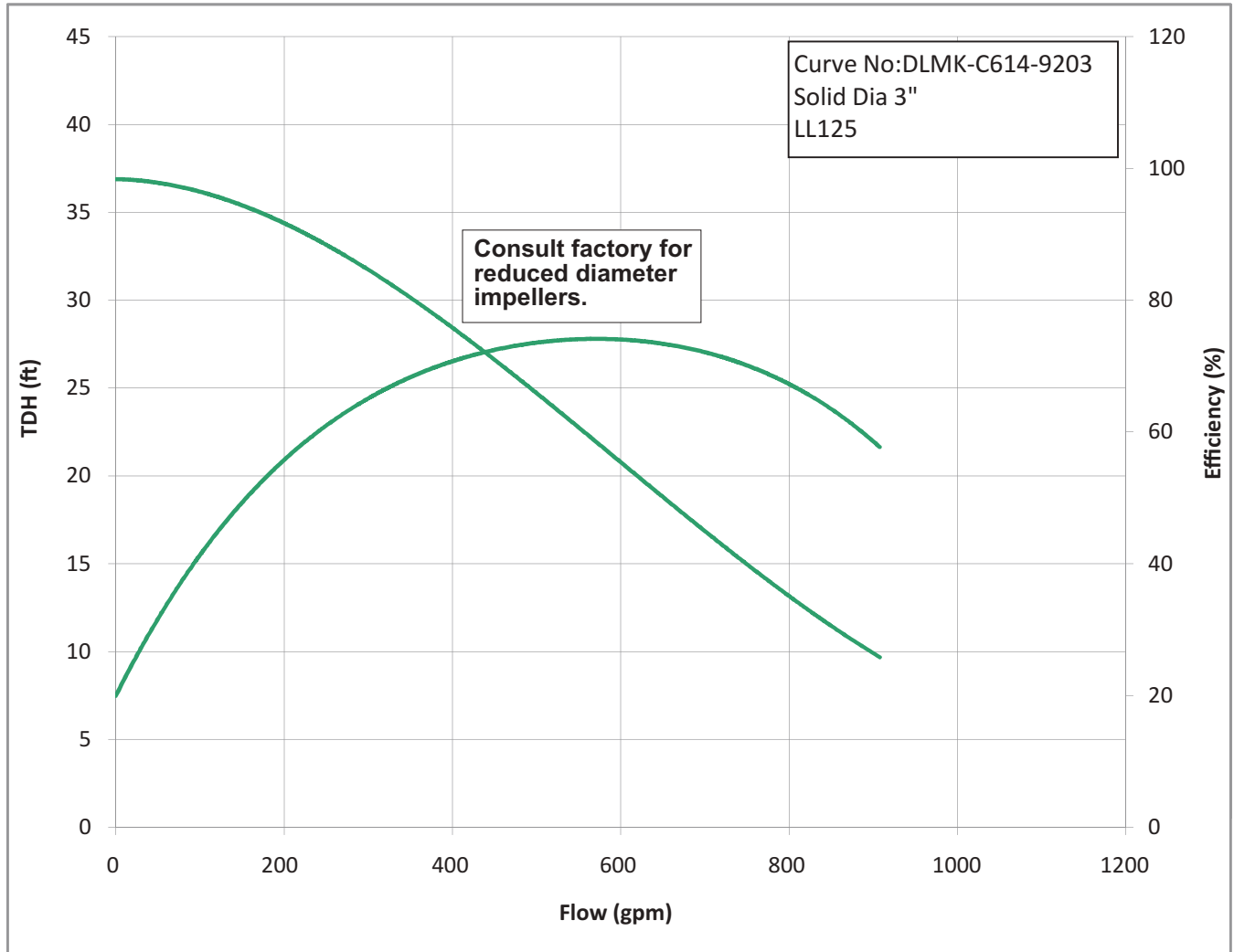

Performance Curves

Project: \_\_\_\_\_ GPM: \_\_\_\_\_ TDH: \_\_\_\_\_ EFF: \_\_\_\_\_ HP: \_\_\_\_\_ Chk'd: \_\_\_\_\_ Date: \_\_\_\_\_

100DLMKFU65.5 (7.5 HP)

Synchronous Speed 1800 RPM

3,4 inch Discharge

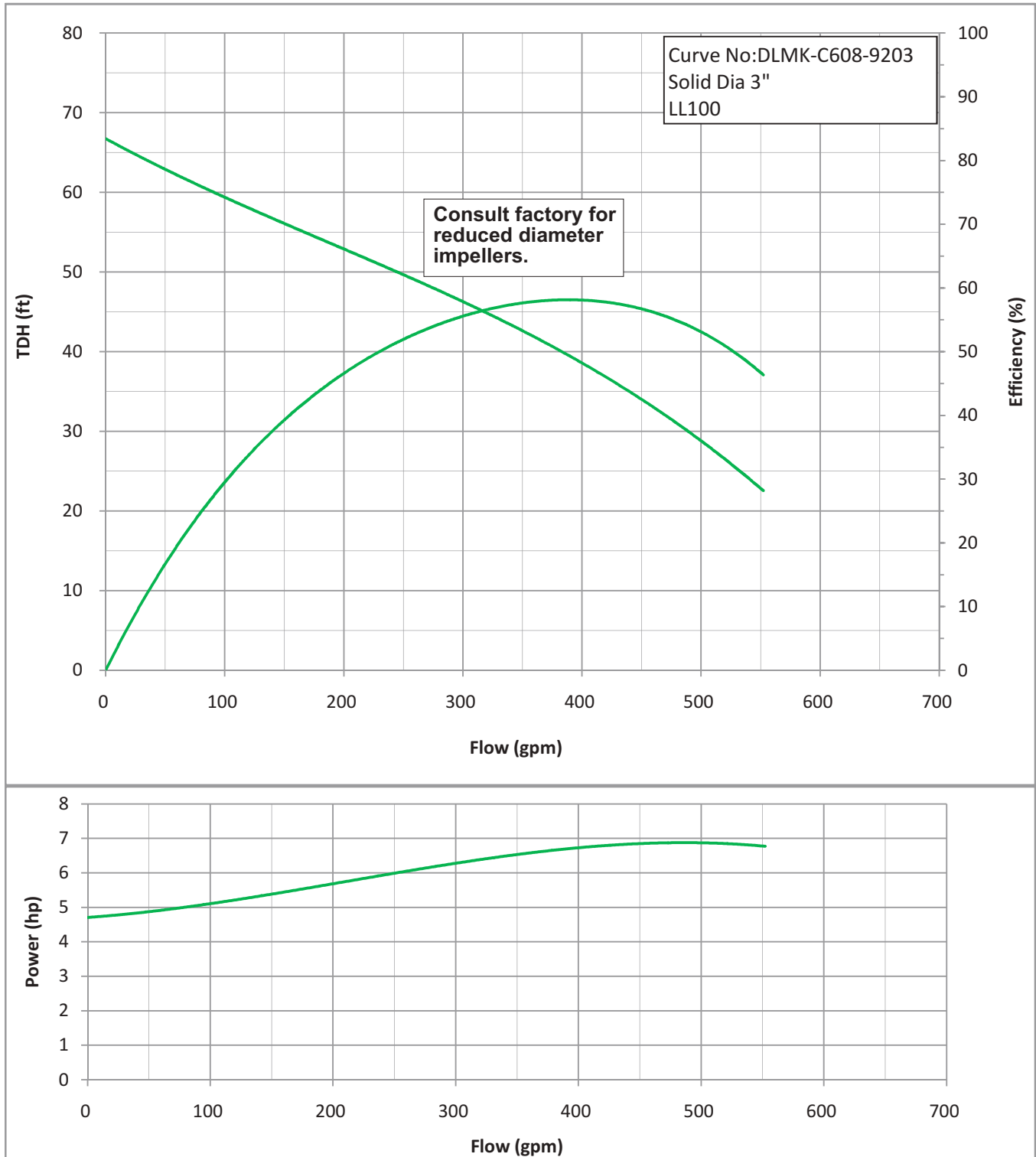

Performance Curves

Project: \_\_\_\_\_ GPM: \_\_\_\_\_ TDH: \_\_\_\_\_ EFF: \_\_\_\_\_ HP: \_\_\_\_\_ Chk'd: \_\_\_\_\_ Date: \_\_\_\_\_

100DLKFU67.5 (10 HP)

Synchronous Speed 1800 RPM

4, 6 Inch Discharge

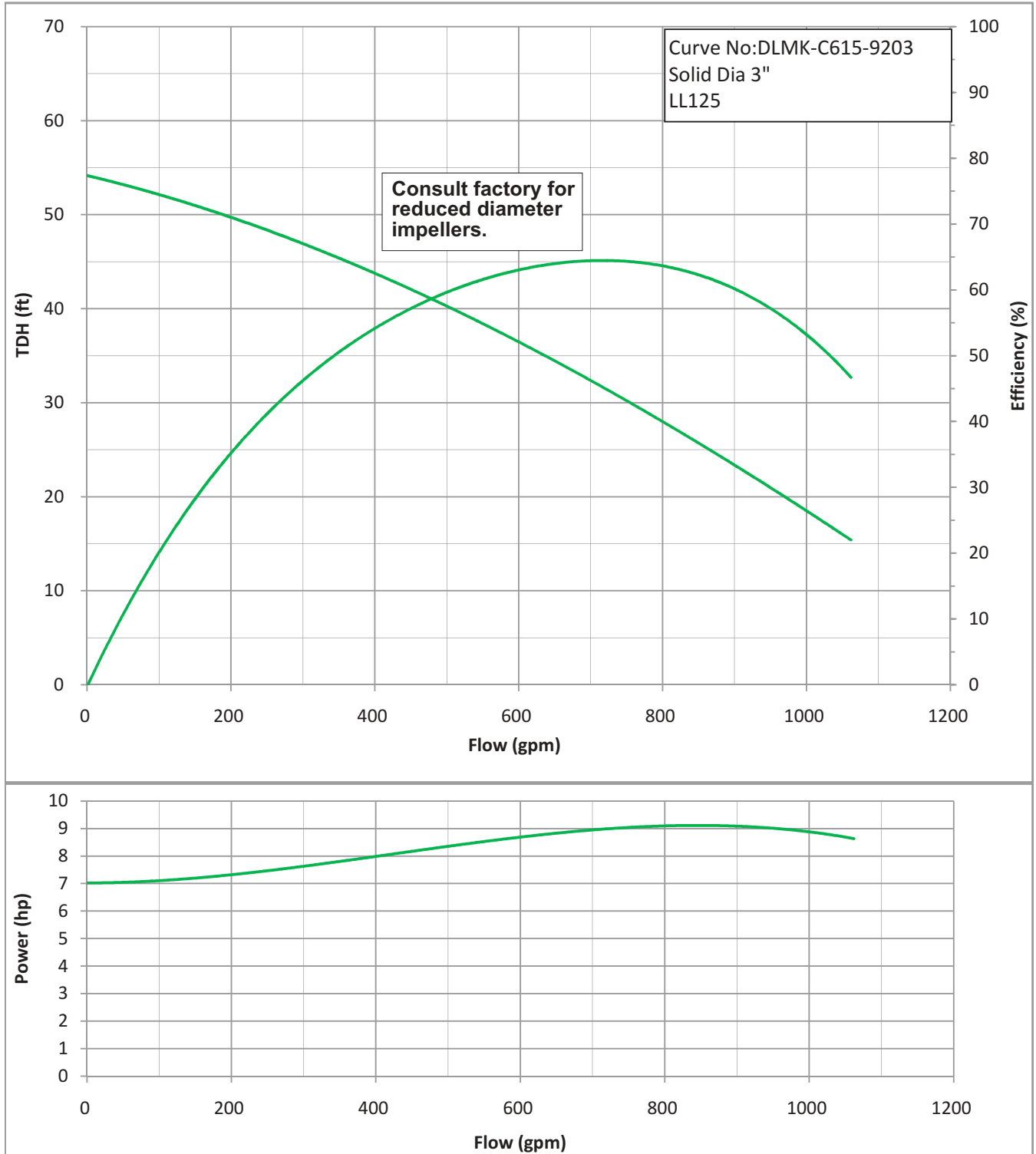

Performance Curves

Project: \_\_\_\_\_ GPM: \_\_\_\_\_ TDH: \_\_\_\_\_ EFF: \_\_\_\_\_ HP: \_\_\_\_\_ Chk'd: \_\_\_\_\_ Date: \_\_\_\_\_

100DLMKFU67.5 (10 HP)

Synchronous Speed 1800 RPM

3,4 inch Discharge

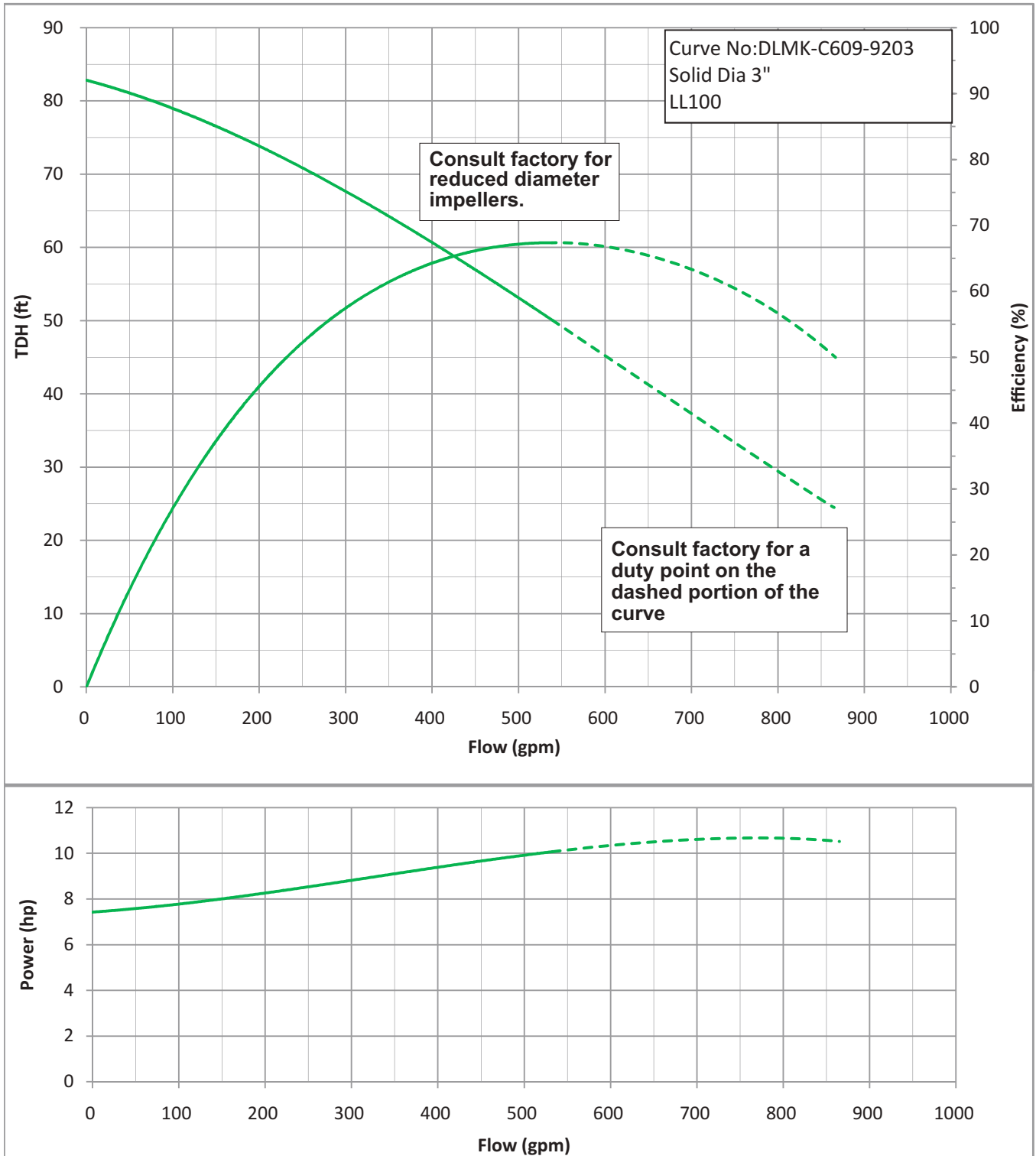

Performance Curves

Project: \_\_\_\_\_ GPM: \_\_\_\_\_ TDH: \_\_\_\_\_ EFF: \_\_\_\_\_ HP: \_\_\_\_\_ Chk'd: \_\_\_\_\_ Date: \_\_\_\_\_

100DLKFU611 (15 HP)

Synchronous Speed 1800 RPM

4, 6 Inch Discharge

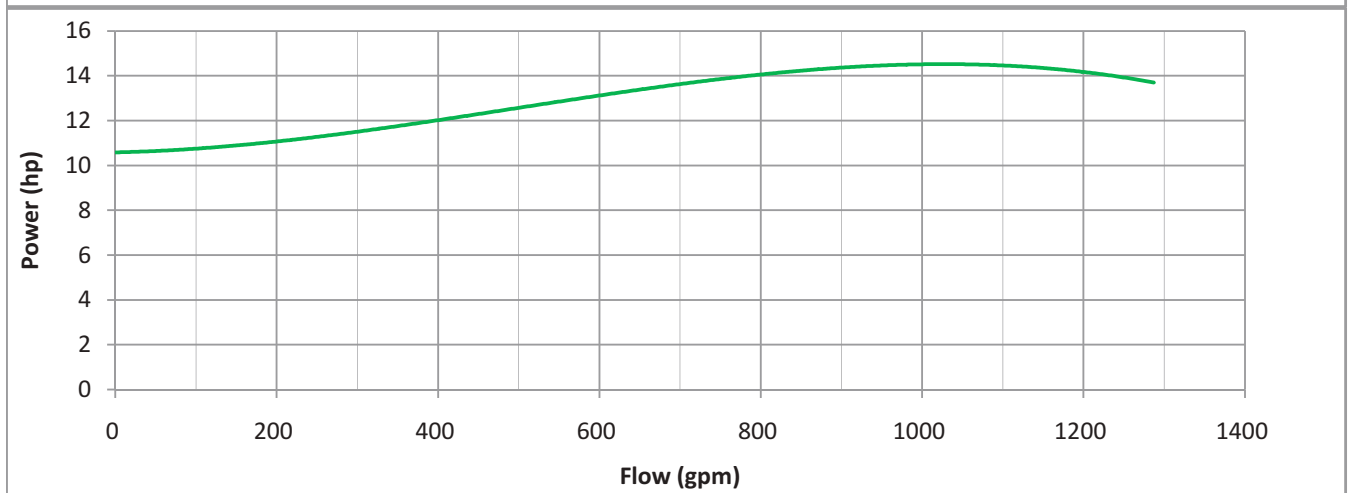
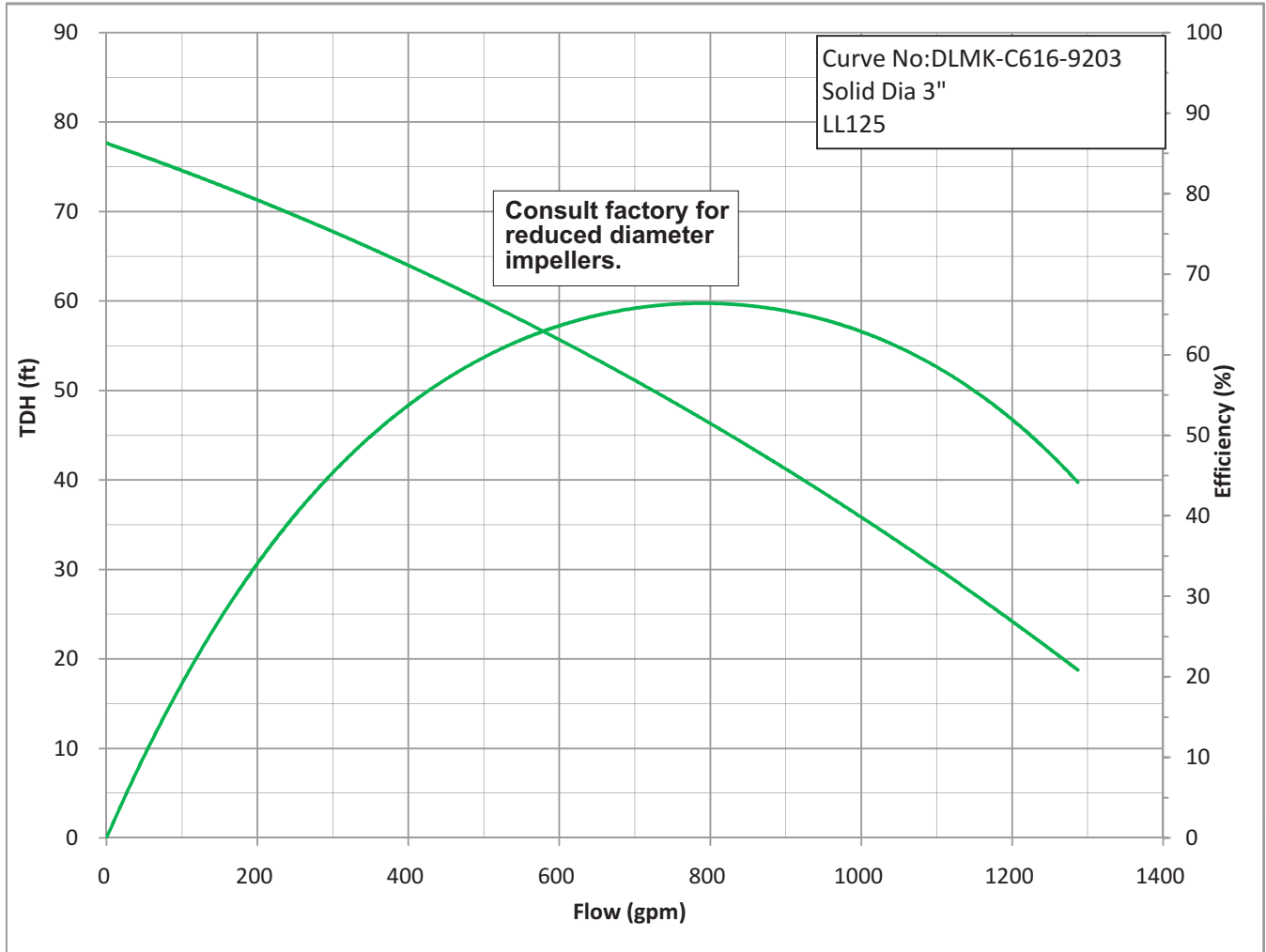

Performance Curves

Project: \_\_\_\_\_ GPM: \_\_\_\_\_ TDH: \_\_\_\_\_ EFF: \_\_\_\_\_ HP: \_\_\_\_\_ Chk'd: \_\_\_\_\_ Date: \_\_\_\_\_

100DLMKFU611 (15 HP)

Synchronous Speed 1800 RPM

3,4 inch Discharge

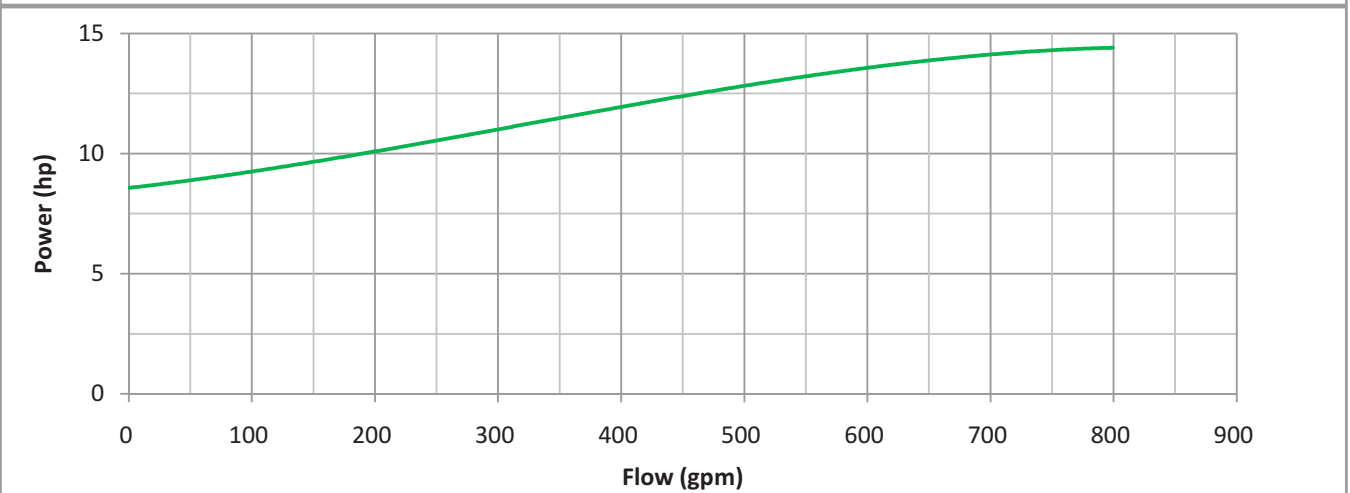
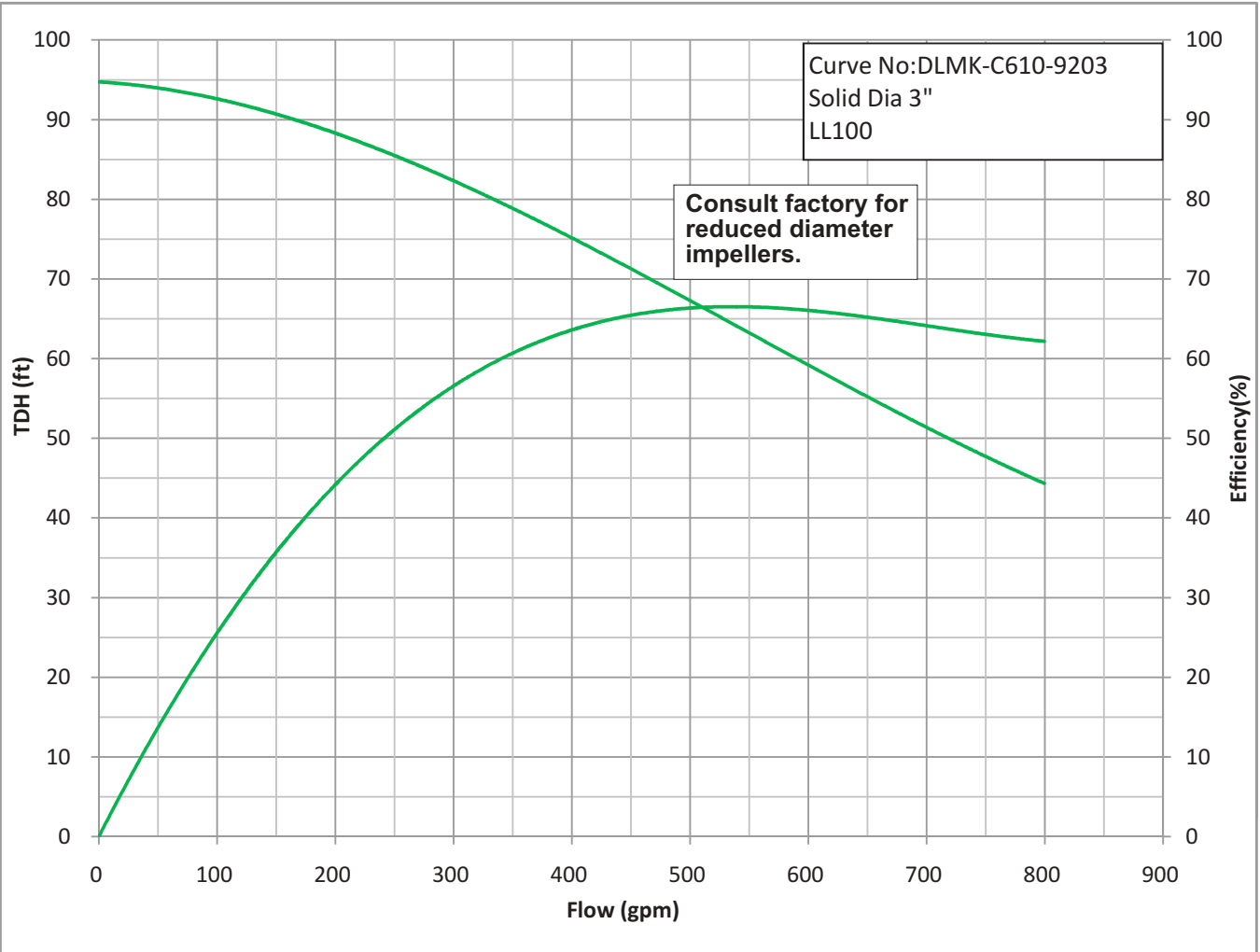

Performance Curves

Project: \_\_\_\_\_ GPM: \_\_\_\_\_ TDH: \_\_\_\_\_ EFF: \_\_\_\_\_ HP: \_\_\_\_\_ Chk'd: \_\_\_\_\_ Date: \_\_\_\_\_

100DLKFU615 (20 hp)

Synchronous Speed 1800 RPM

4, 6 Inch Discharge

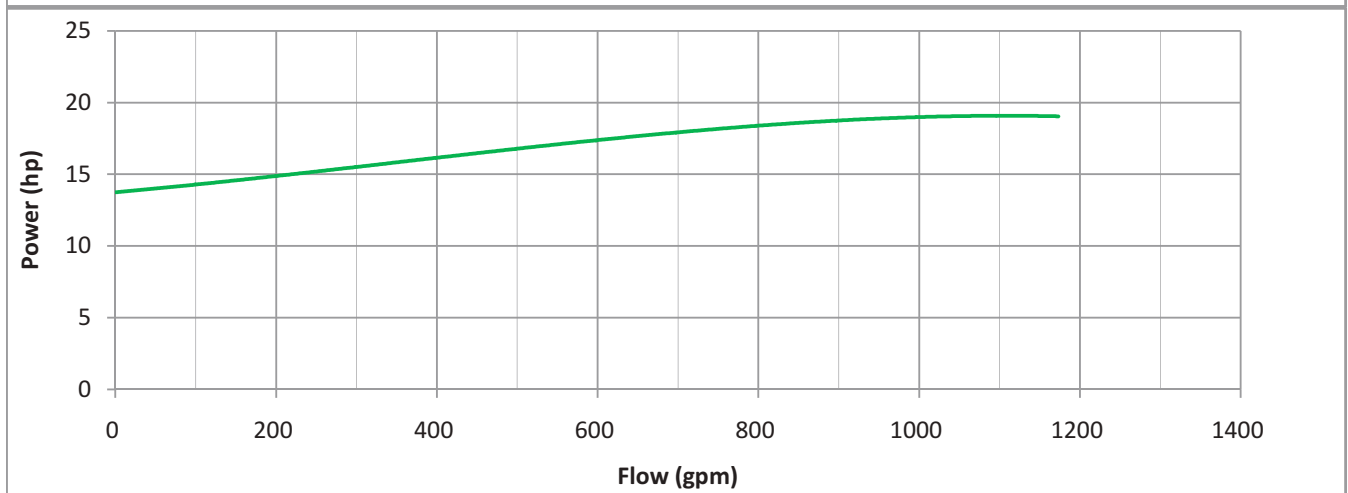
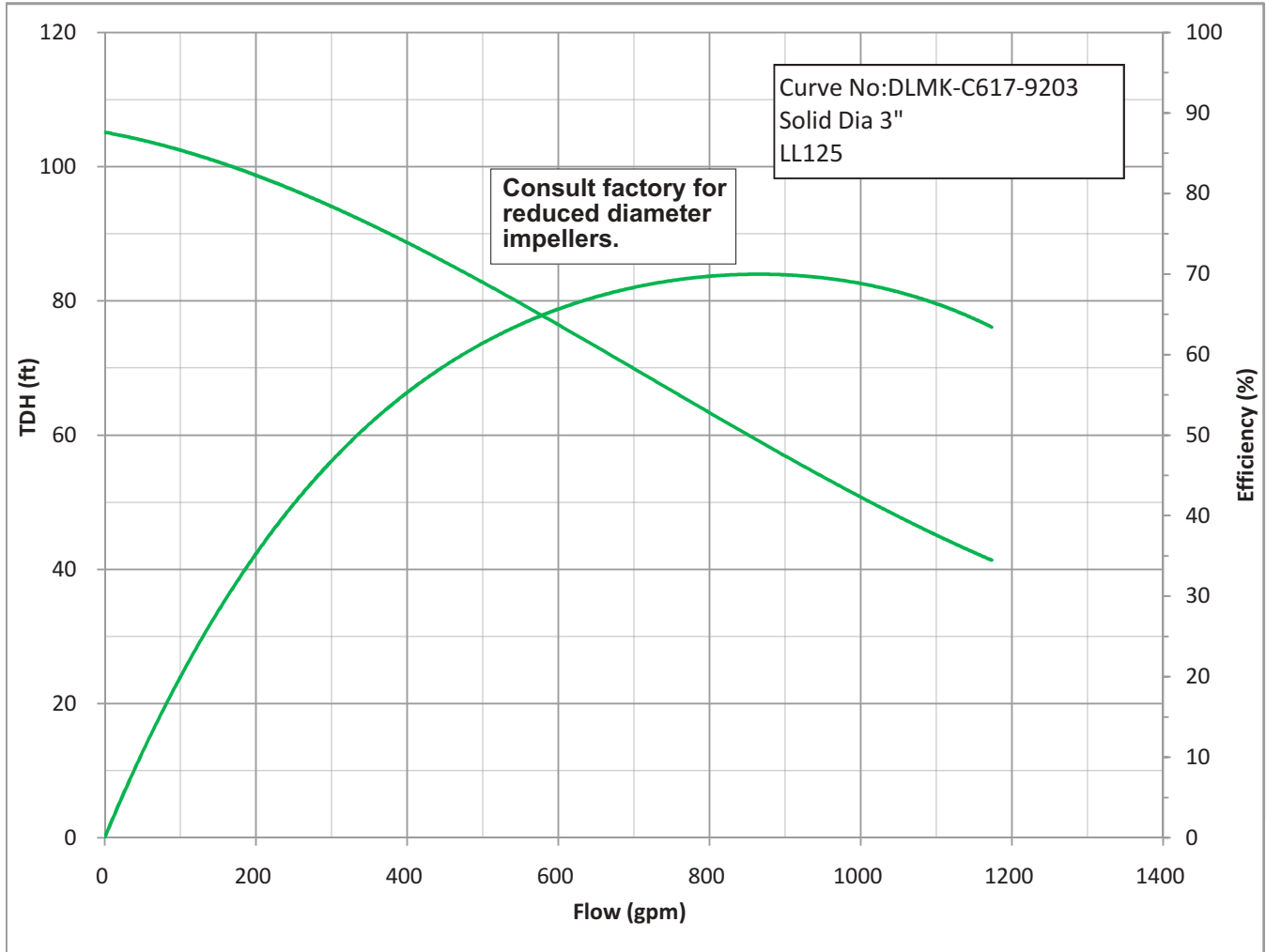



**Performance Curves**

Project: \_\_\_\_\_ GPM: \_\_\_\_\_ TDH: \_\_\_\_\_ EFF: \_\_\_\_\_ HP: \_\_\_\_\_ Chk'd: \_\_\_\_\_ Date: \_\_\_\_\_

**100DLMKFU615 (20 HP)**

**Synchronous Speed 1800 RPM**

**3,4 inch Discharge**

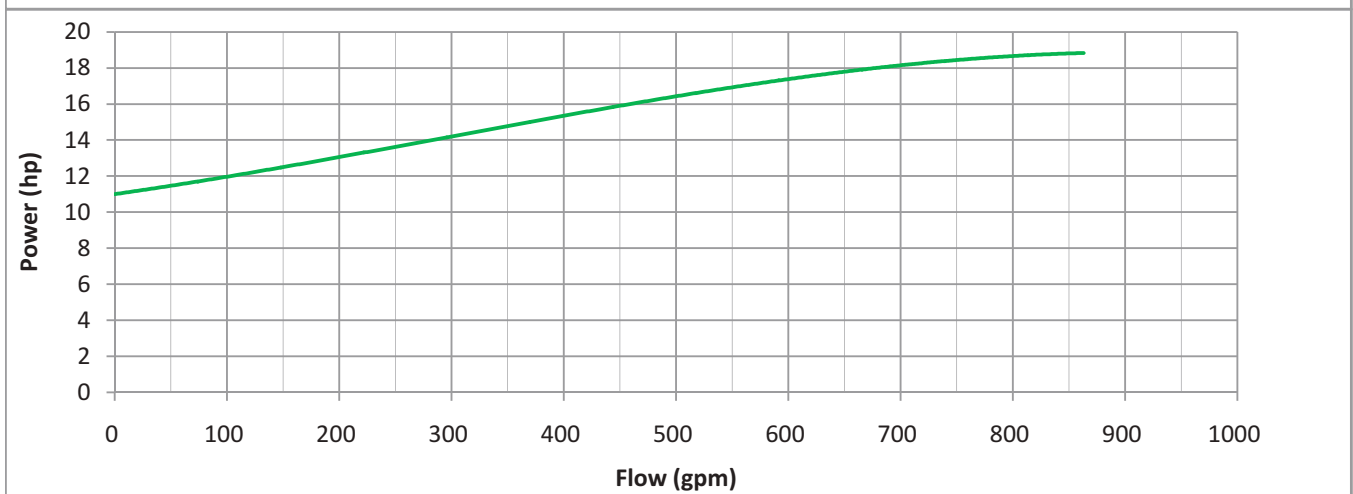
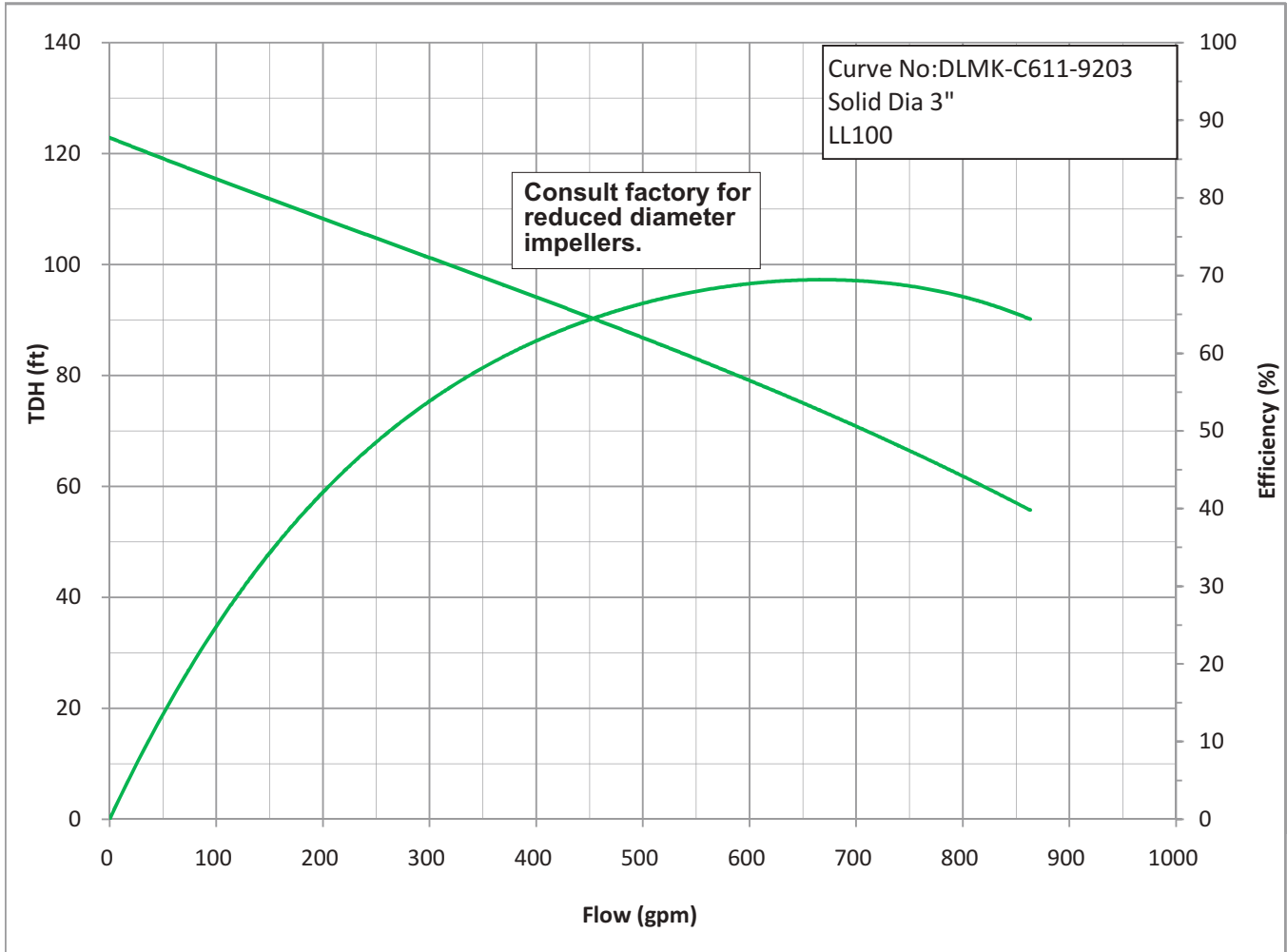

**Performance Curves**

Project: \_\_\_\_\_ GPM: \_\_\_\_\_ TDH: \_\_\_\_\_ EFF: \_\_\_\_\_ HP: \_\_\_\_\_ Chk'd: \_\_\_\_\_ Date: \_\_\_\_\_

**100DLMKFU618 (25 HP)**

**Synchronous Speed 1800 RPM**

**3,4 inch Discharge**

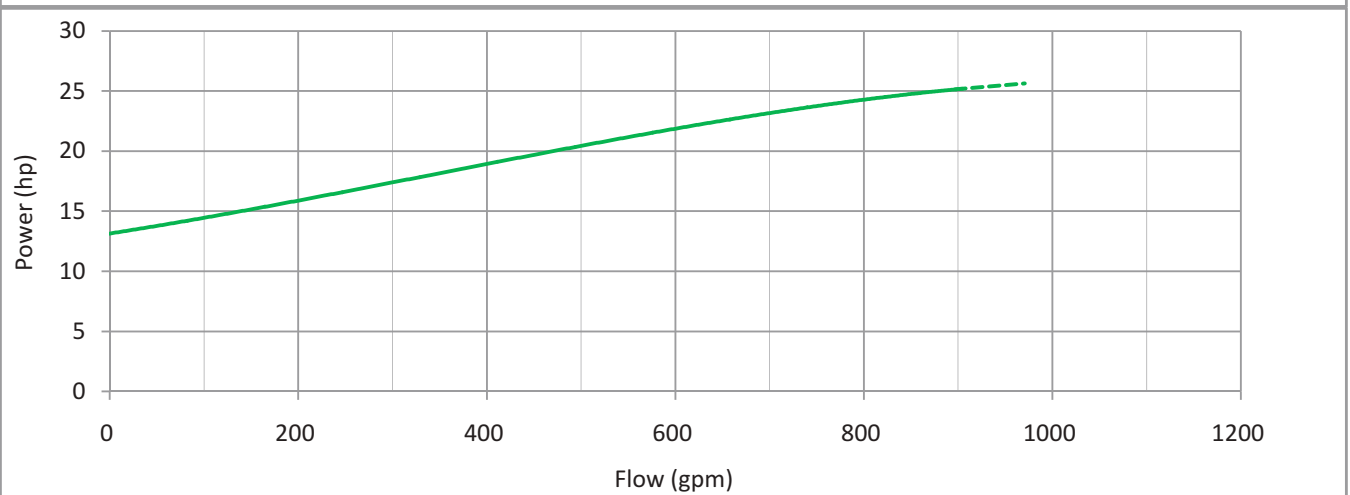
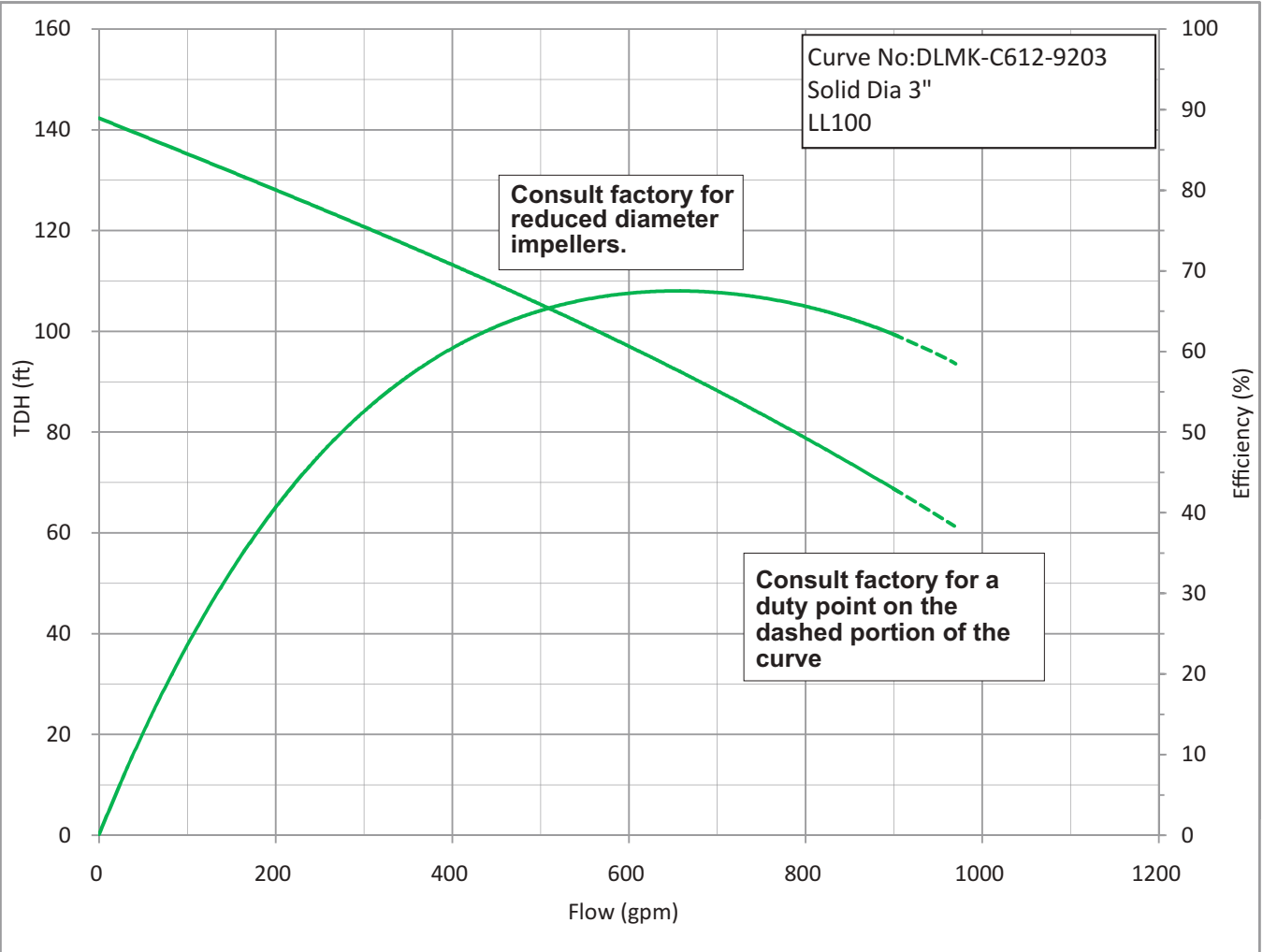

Performance Curves

Project: \_\_\_\_\_ GPM: \_\_\_\_\_ TDH: \_\_\_\_\_ EFF: \_\_\_\_\_ HP: \_\_\_\_\_ Chk'd: \_\_\_\_\_ Date: \_\_\_\_\_

100DLKFU618 (25 HP)

Synchronous Speed 1800 RPM

4, 6 inch Discharge

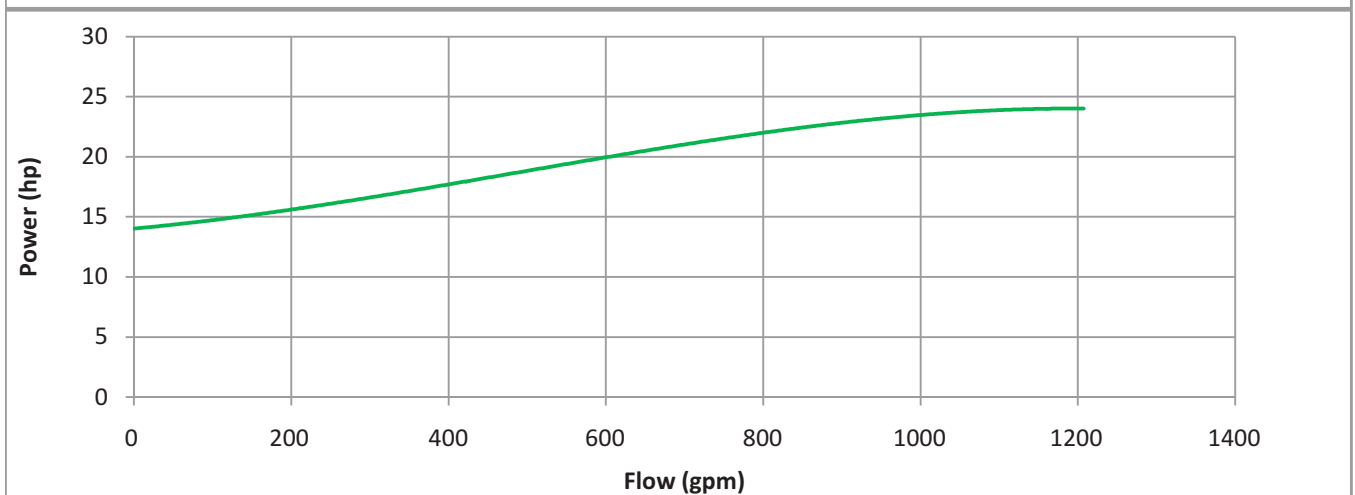
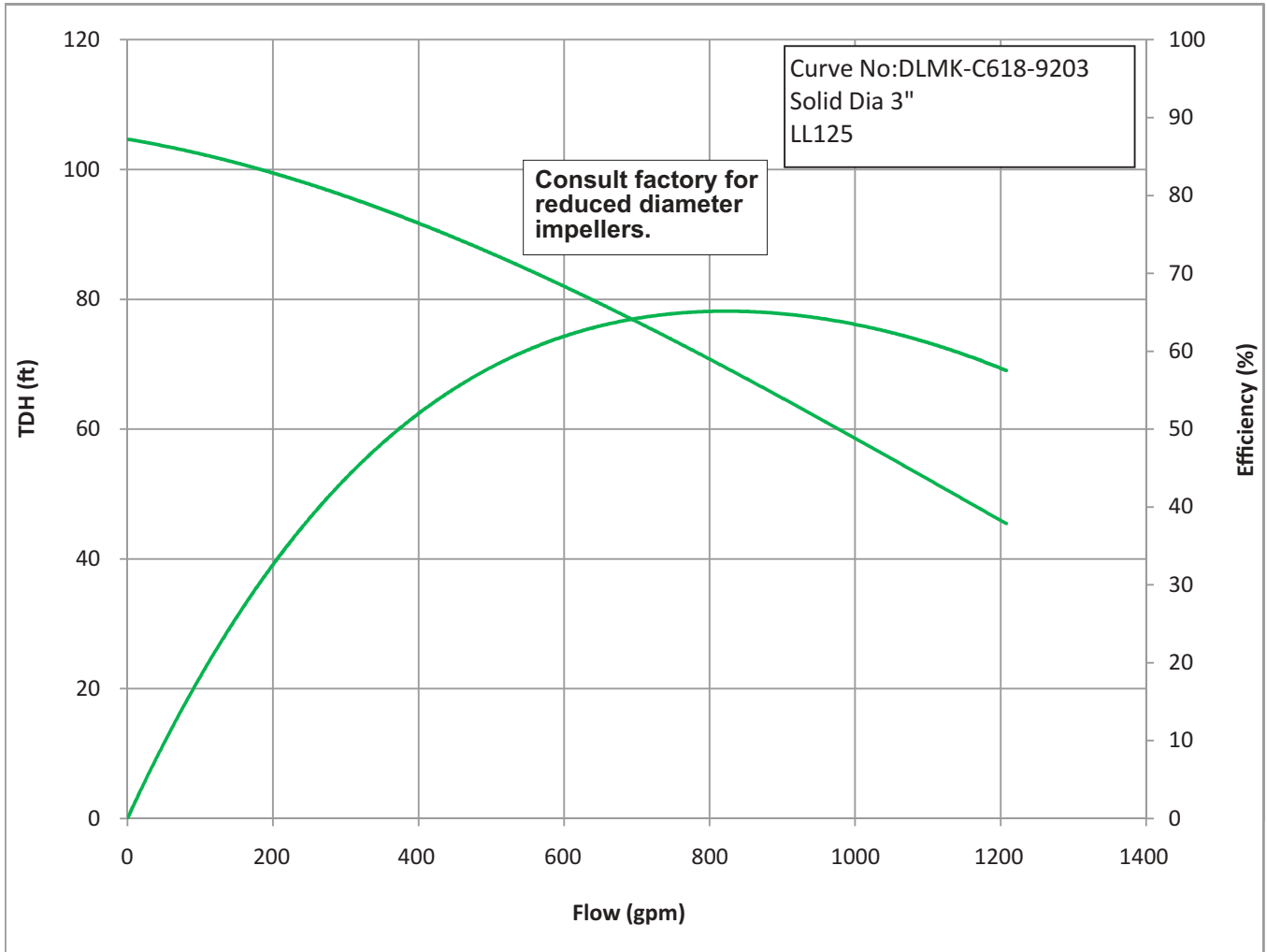

Performance Curves

Project: \_\_\_\_\_ GPM: \_\_\_\_\_ TDH: \_\_\_\_\_ EFF: \_\_\_\_\_ HP: \_\_\_\_\_ Chk'd: \_\_\_\_\_ Date: \_\_\_\_\_

100DLMKFU622 (30 HP)

Synchronous Speed 1800 RPM

3,4 inch Discharge

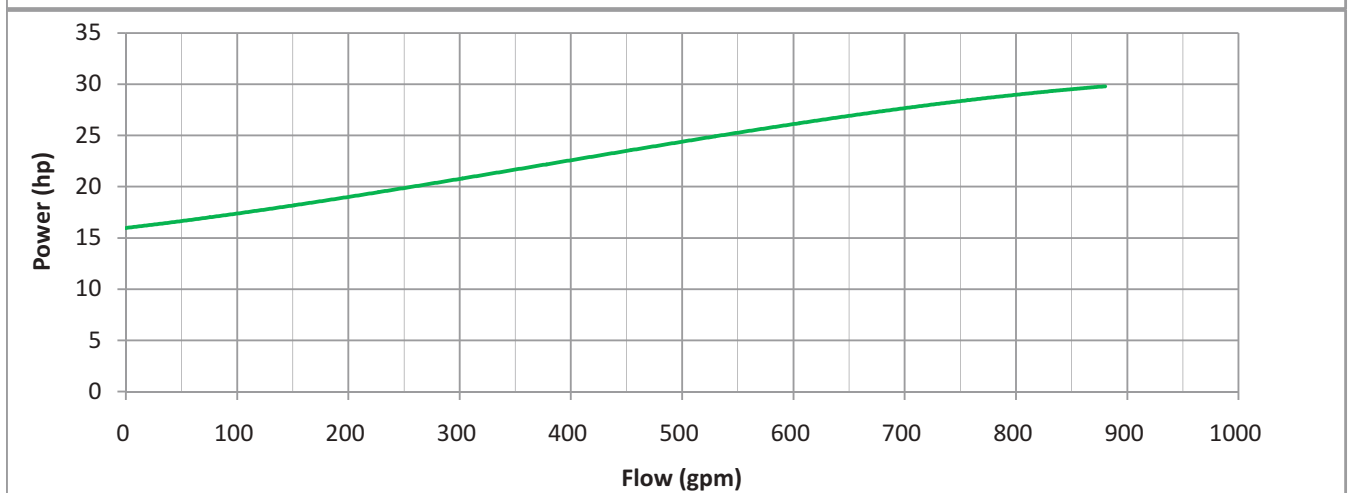
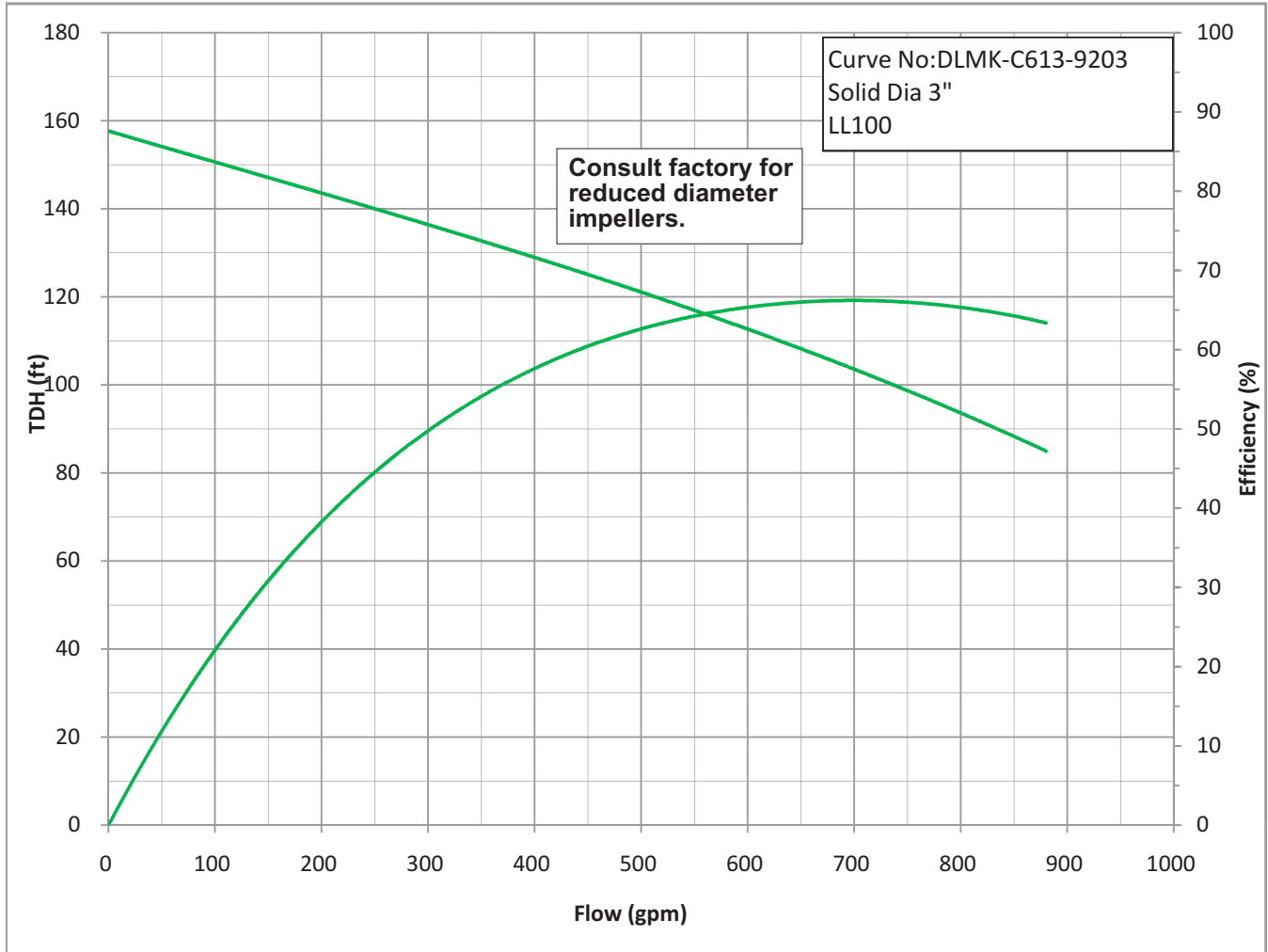

Performance Curves

Project: \_\_\_\_\_ GPM: \_\_\_\_\_ TDH: \_\_\_\_\_ EFF: \_\_\_\_\_ HP: \_\_\_\_\_ Chk'd: \_\_\_\_\_ Date: \_\_\_\_\_

100DLKFU622 (30 HP)

Synchronous Speed 1800 RPM

4, 6inch Discharge

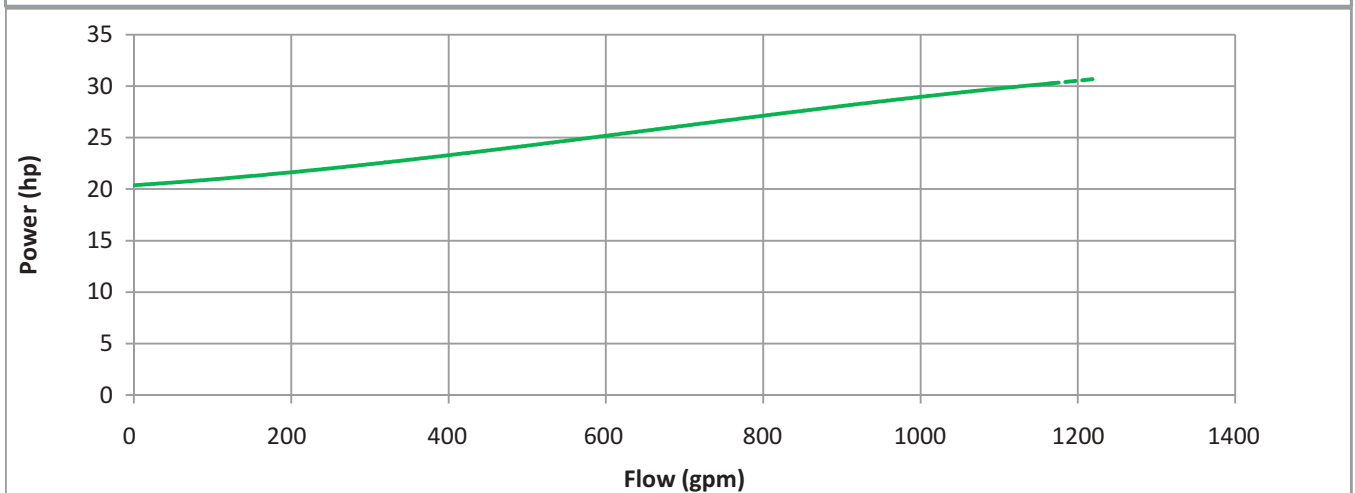
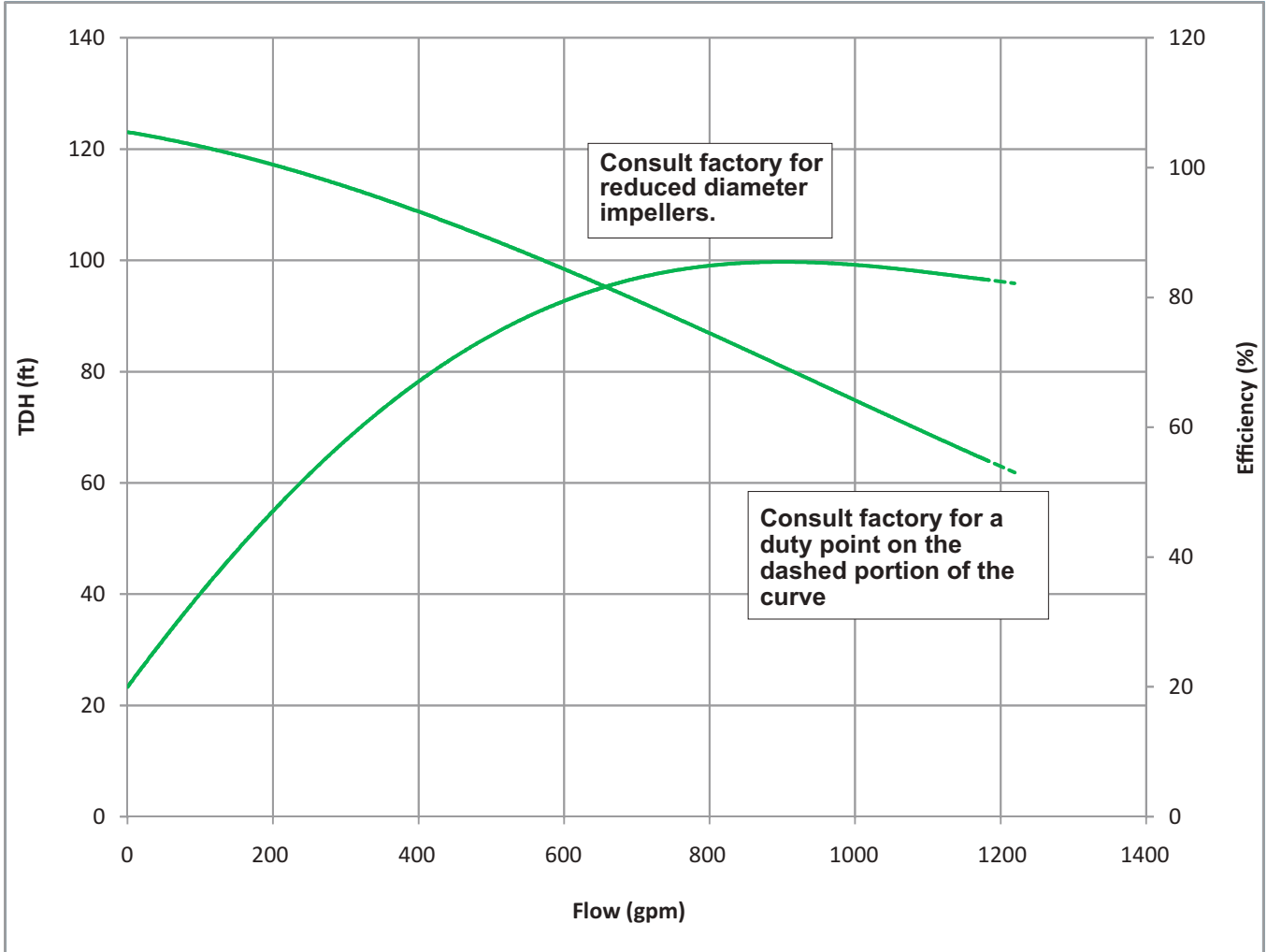

Performance Curves

Project: \_\_\_\_\_ GPM: \_\_\_\_\_ TDH: \_\_\_\_\_ EFF: \_\_\_\_\_ HP: \_\_\_\_\_ Chk'd: \_\_\_\_\_ Date: \_\_\_\_\_

150DLKFU67.5 (10 HP)

Synchronous Speed 1800 RPM

6, 8 inch Discharge

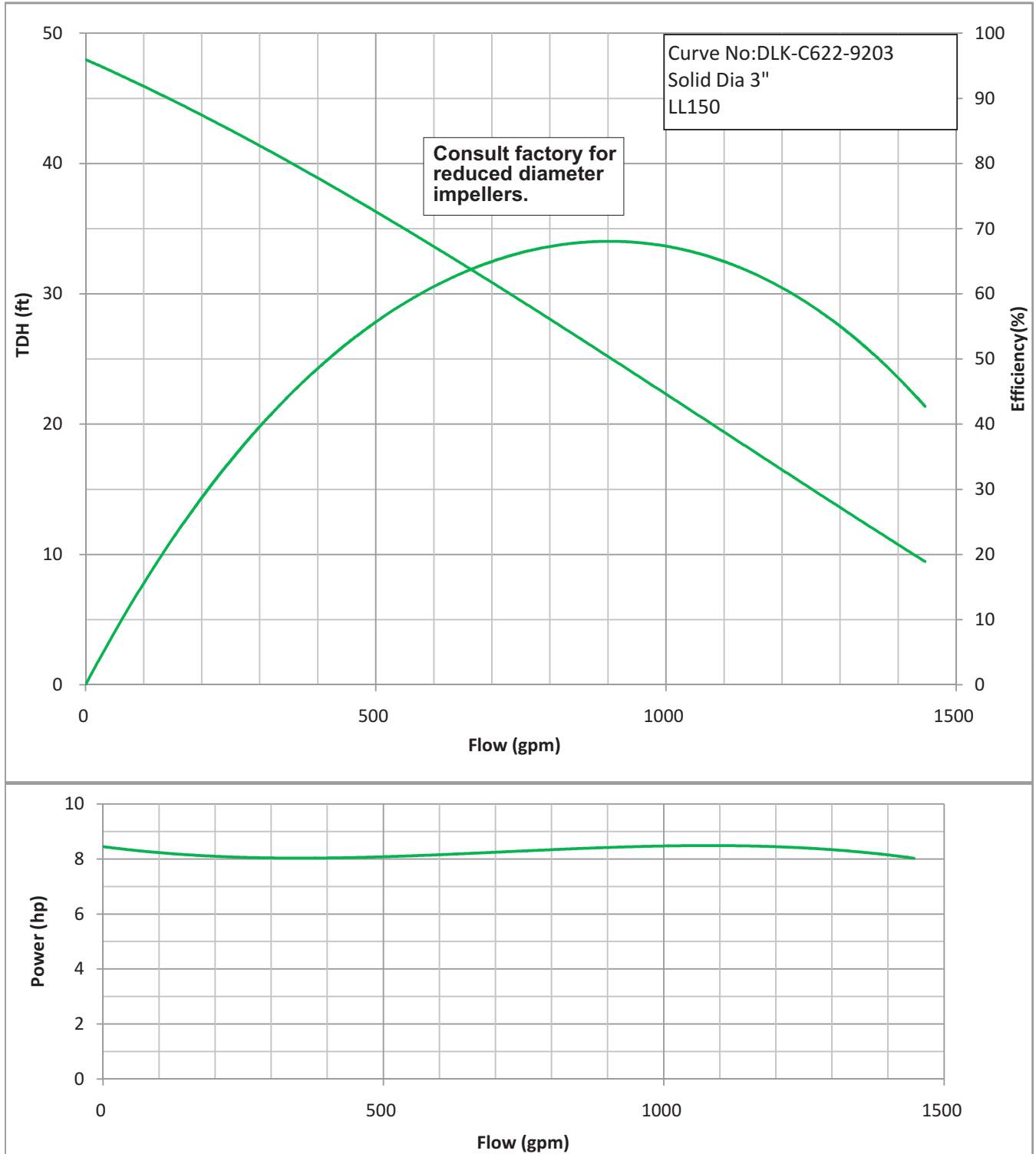

**Performance Curves**

Project: \_\_\_\_\_ GPM: \_\_\_\_\_ TDH: \_\_\_\_\_ EFF: \_\_\_\_\_ HP: \_\_\_\_\_ Chk'd: \_\_\_\_\_ Date: \_\_\_\_\_

**150DLKFU611 (15 HP)**

**Synchronous Speed 1800 RPM**

**6, 8 inch Discharge**

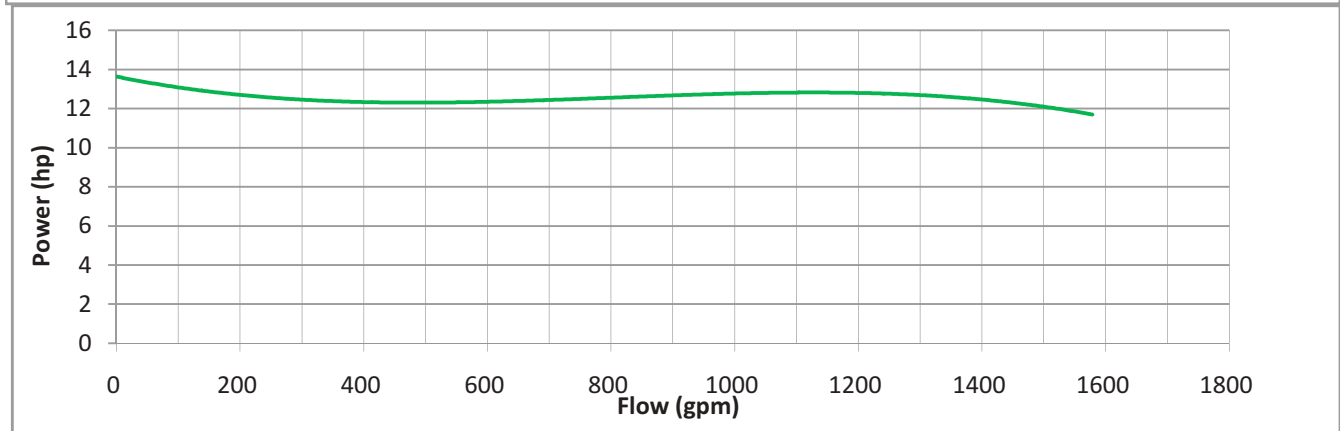
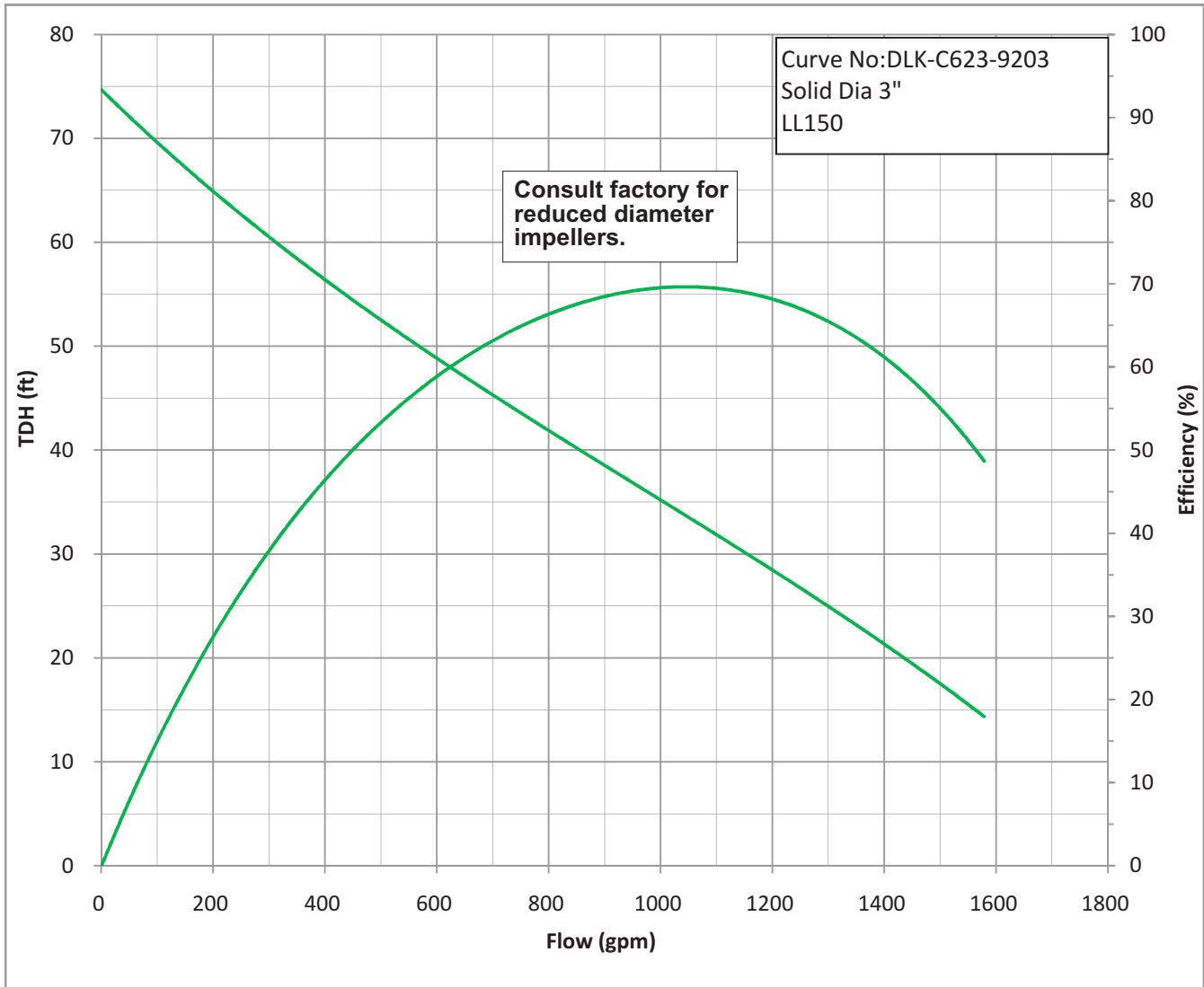

Performance Curves

Project: \_\_\_\_\_ GPM: \_\_\_\_\_ TDH: \_\_\_\_\_ EFF: \_\_\_\_\_ HP: \_\_\_\_\_ Chk'd: \_\_\_\_\_ Date: \_\_\_\_\_

150DLKFU615 (20 HP)

Synchronous Speed 1800 RPM

6, 8 inch Discharge

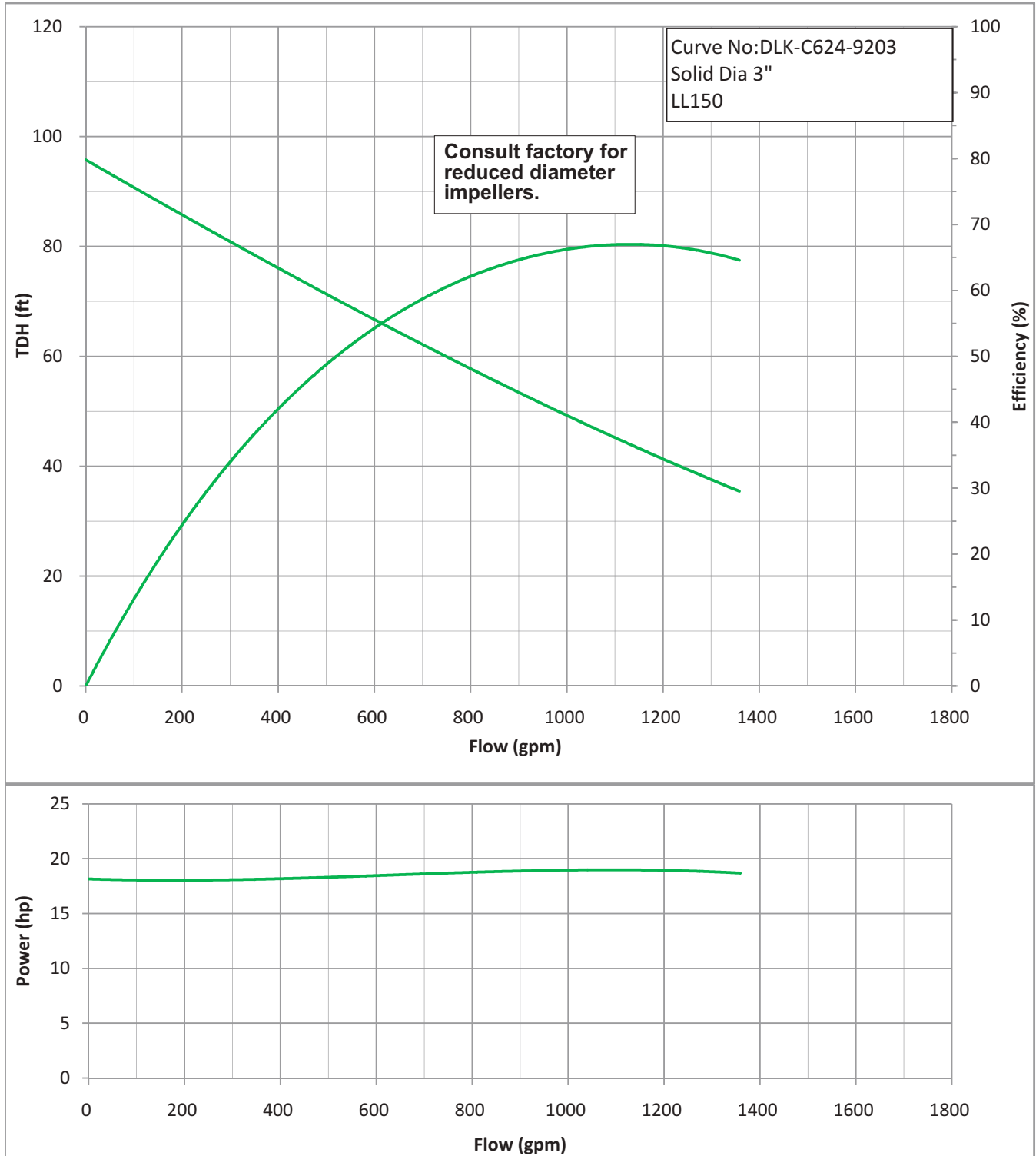



Performance Curves

Project: \_\_\_\_\_ GPM: \_\_\_\_\_ TDH: \_\_\_\_\_ EFF: \_\_\_\_\_ HP: \_\_\_\_\_ Chk'd: \_\_\_\_\_ Date: \_\_\_\_\_

150DLKFU618 (25 HP)

Synchronous Speed 1800 RPM

6, 8 inch Discharge

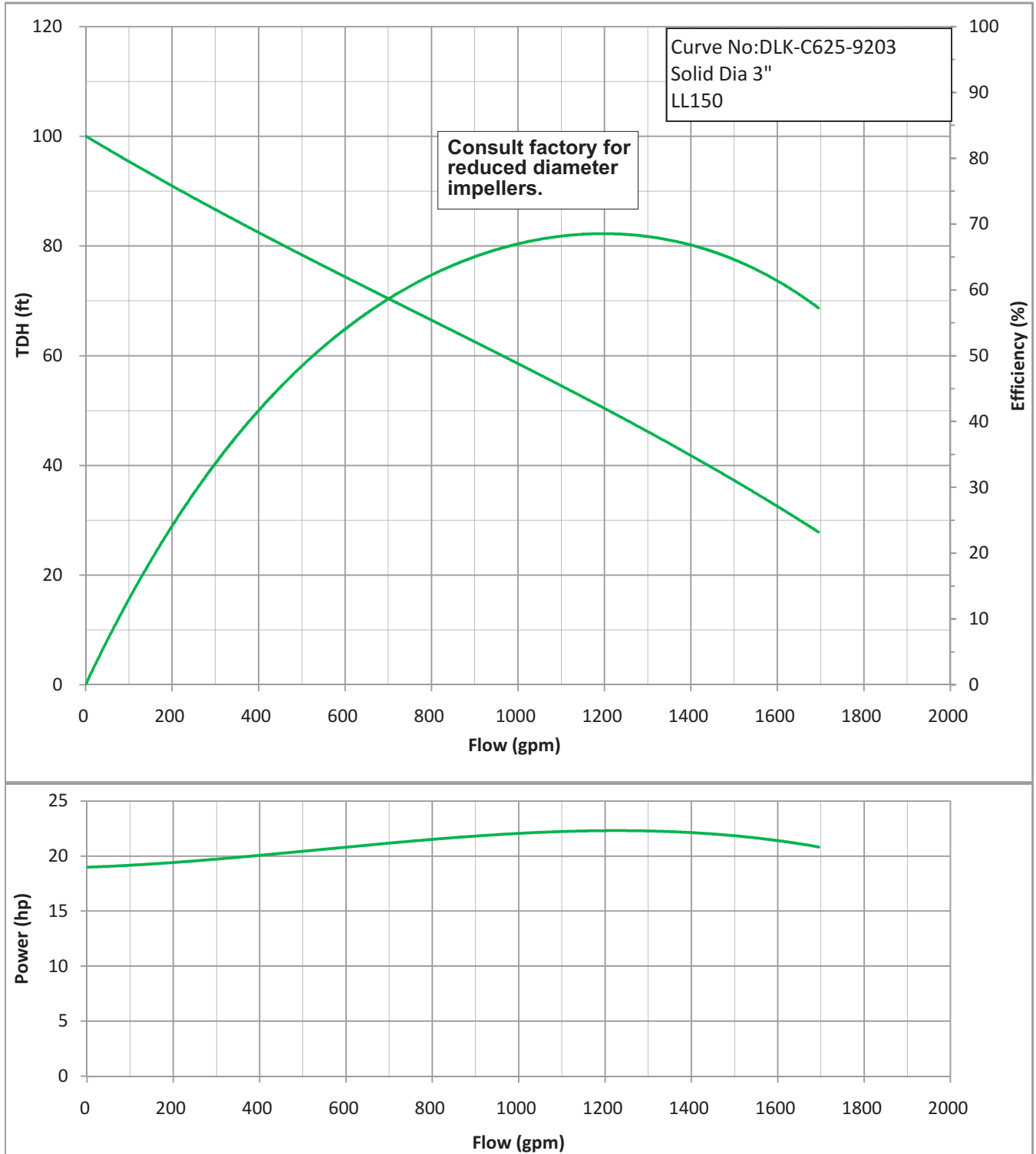

Performance Curves

Project: \_\_\_\_\_ GPM: \_\_\_\_\_ TDH: \_\_\_\_\_ EFF: \_\_\_\_\_ HP: \_\_\_\_\_ Chk'd: \_\_\_\_\_ Date: \_\_\_\_\_

150DLKFU622 (30 HP)

Synchronous Speed 1800 RPM

6, 8 inch Discharge

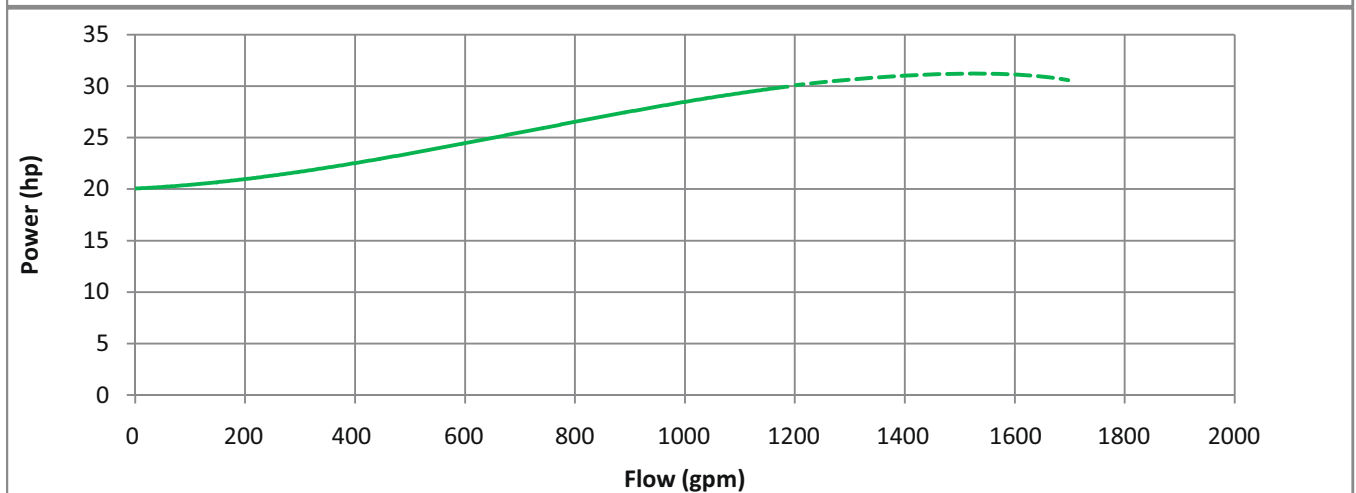
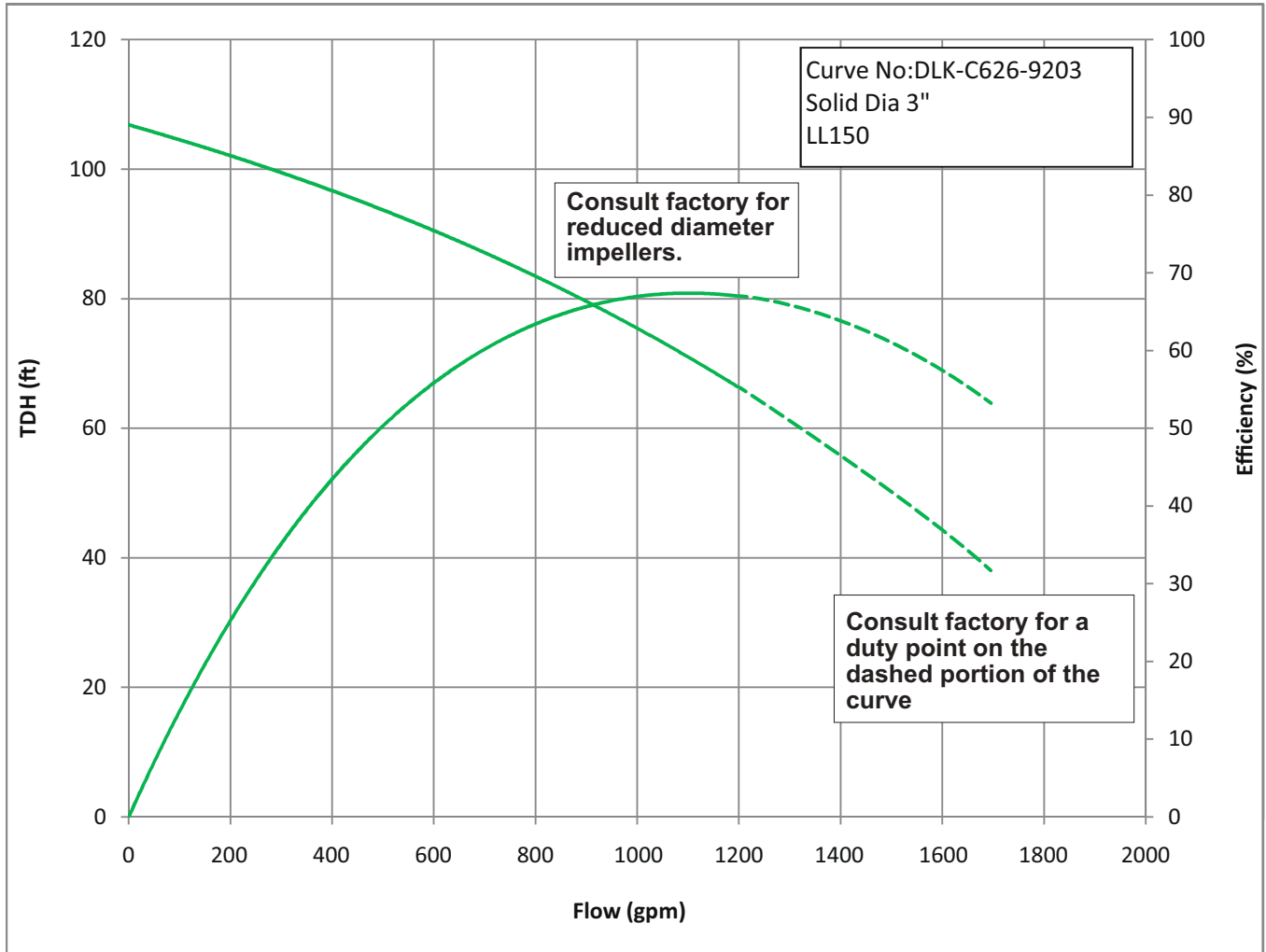

**Performance Curves**

Project: \_\_\_\_\_ GPM: \_\_\_\_\_ TDH: \_\_\_\_\_ EFF: \_\_\_\_\_ HP: \_\_\_\_\_ Chk'd: \_\_\_\_\_ Date: \_\_\_\_\_

**200DLKFU67.5 ( 10 HP)**

**Synchronous Speed 1800 RPM**

**6, 8 inch Discharge**

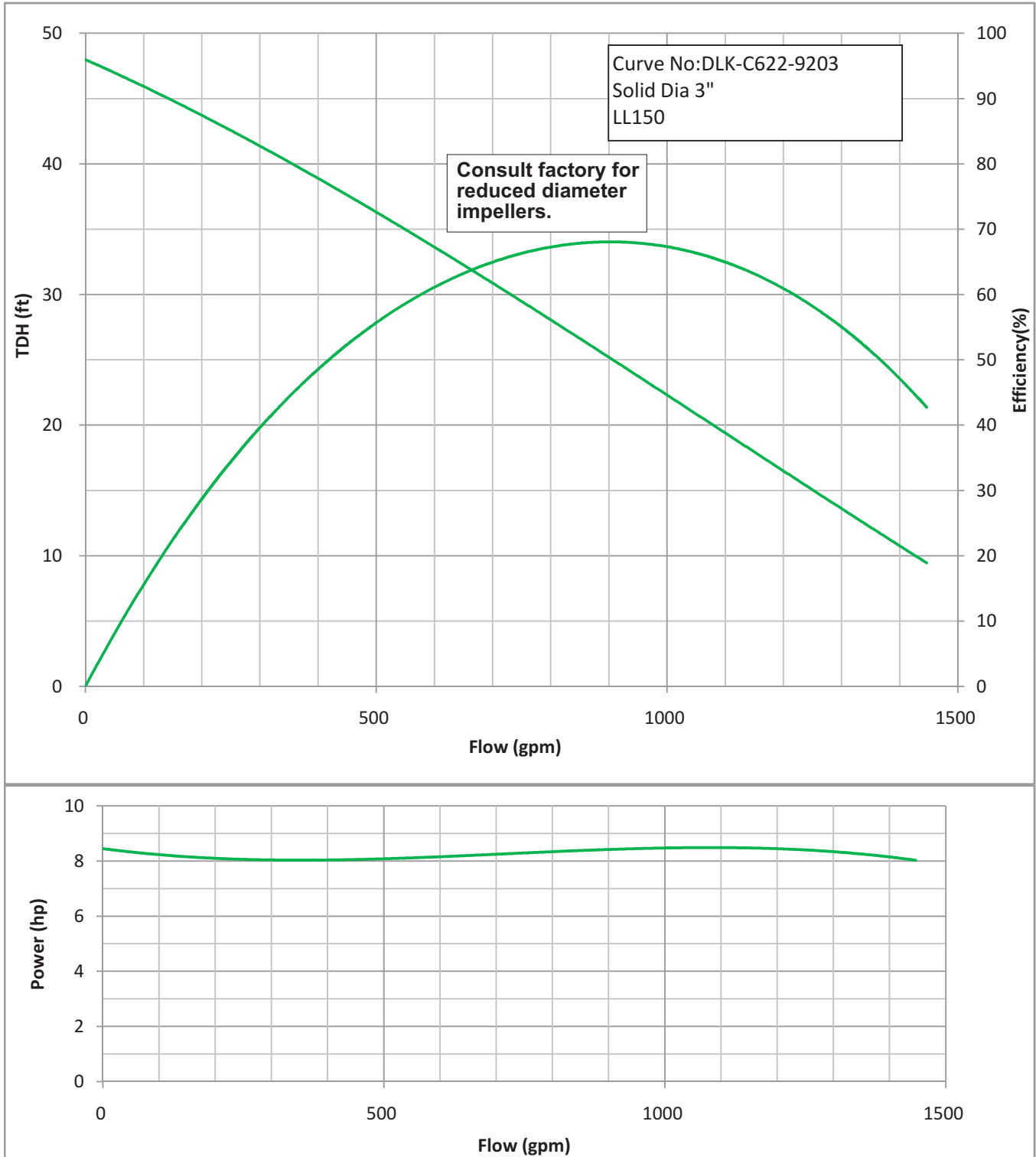

**Performance Curves**

Project: \_\_\_\_\_ GPM: \_\_\_\_\_ TDH: \_\_\_\_\_ EFF: \_\_\_\_\_ HP: \_\_\_\_\_ Chk'd: \_\_\_\_\_ Date: \_\_\_\_\_

**200DLKFU611 (15 HP)**

**Synchronous Speed 1800 RPM**

**6, 8 inch Discharge**

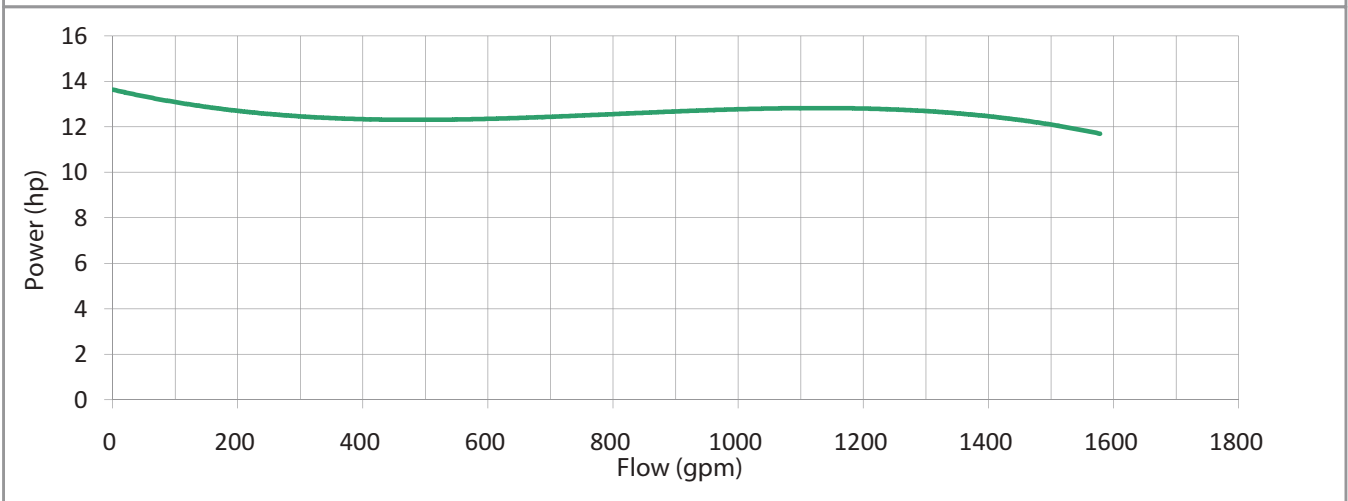
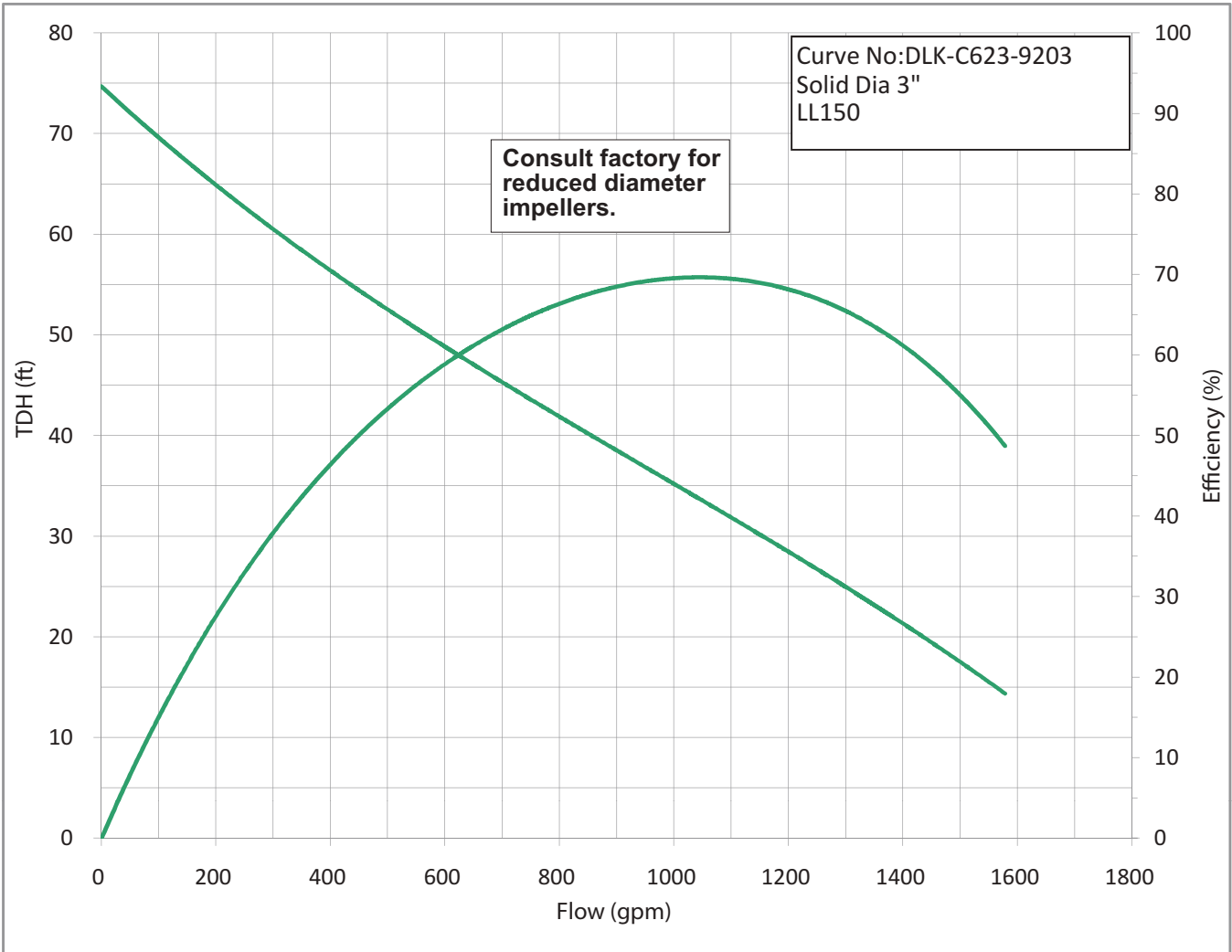

Performance Curves

Project: \_\_\_\_\_ GPM: \_\_\_\_\_ TDH: \_\_\_\_\_ EFF: \_\_\_\_\_ HP: \_\_\_\_\_ Chk'd: \_\_\_\_\_ Date: \_\_\_\_\_

200DLKFU615 (20 HP)

Synchronous Speed 1800 RPM

6, 8 inch Discharge

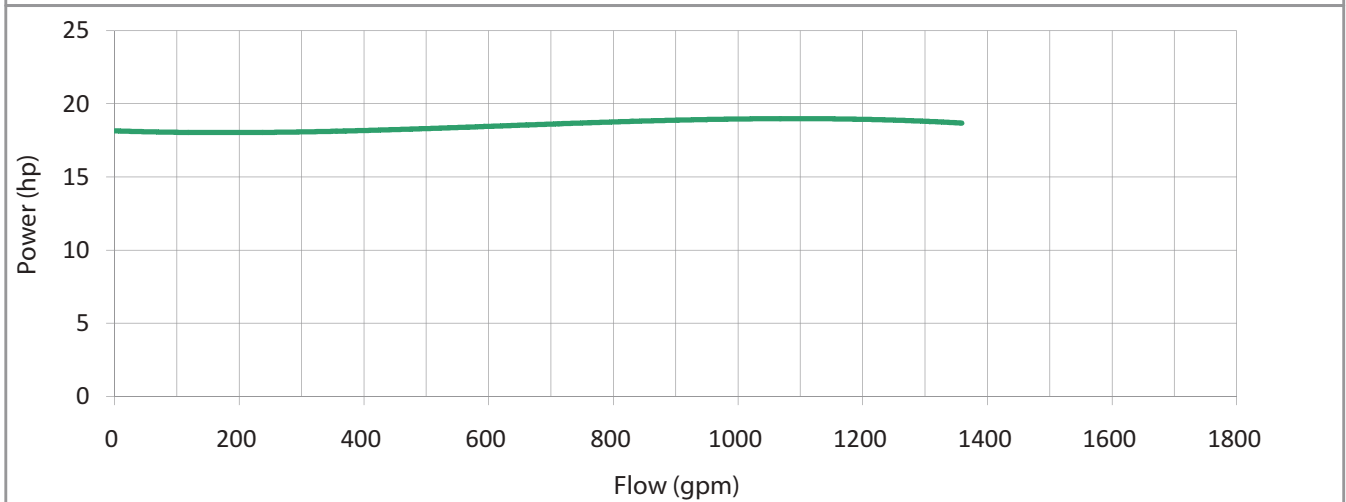
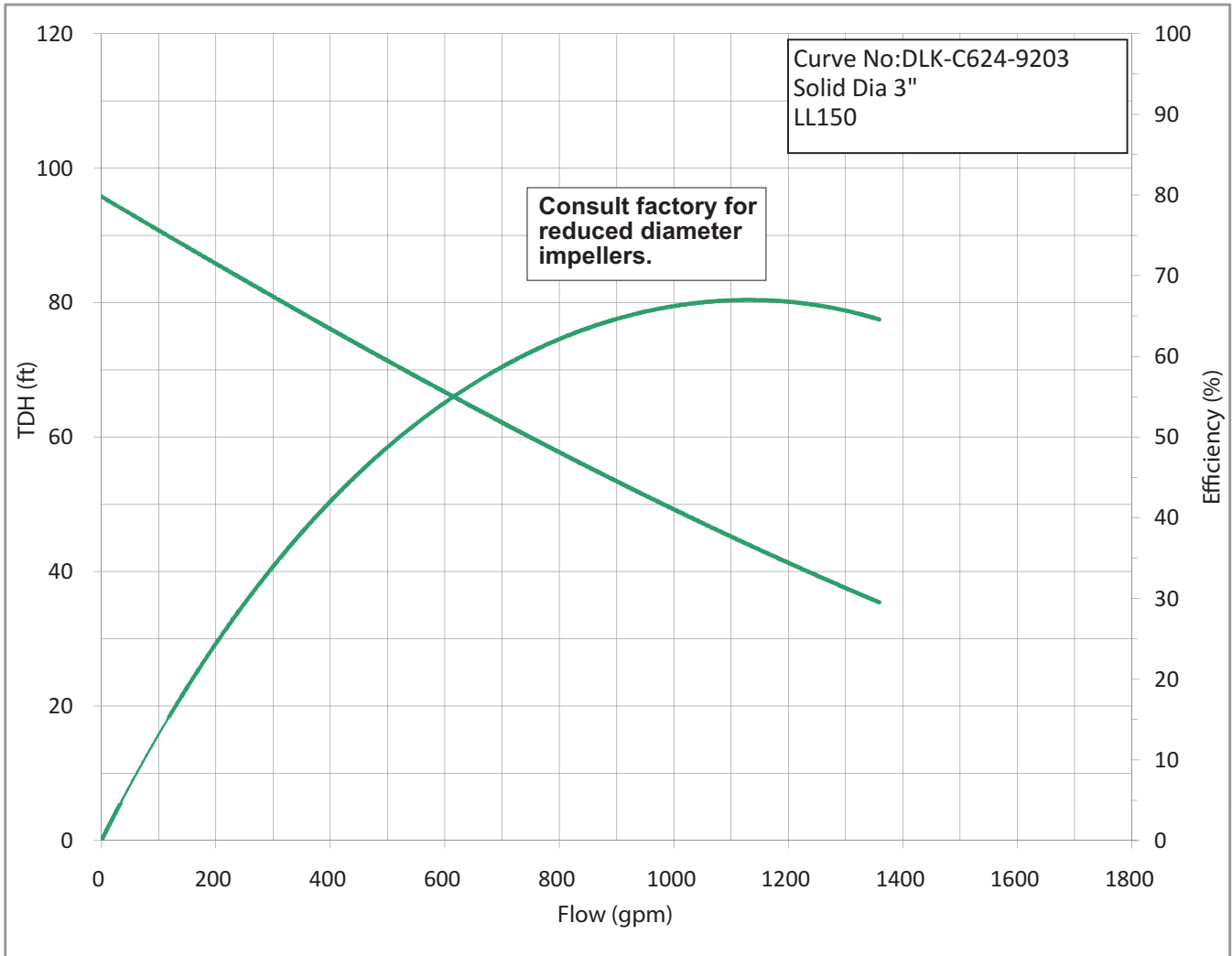

Performance Curves

Project: \_\_\_\_\_ GPM: \_\_\_\_\_ TDH: \_\_\_\_\_ EFF: \_\_\_\_\_ HP: \_\_\_\_\_ Chk'd: \_\_\_\_\_ Date: \_\_\_\_\_

200DLKFU618 (25 HP)

Synchronous Speed 1800 RPM

6, 8 inch Discharge

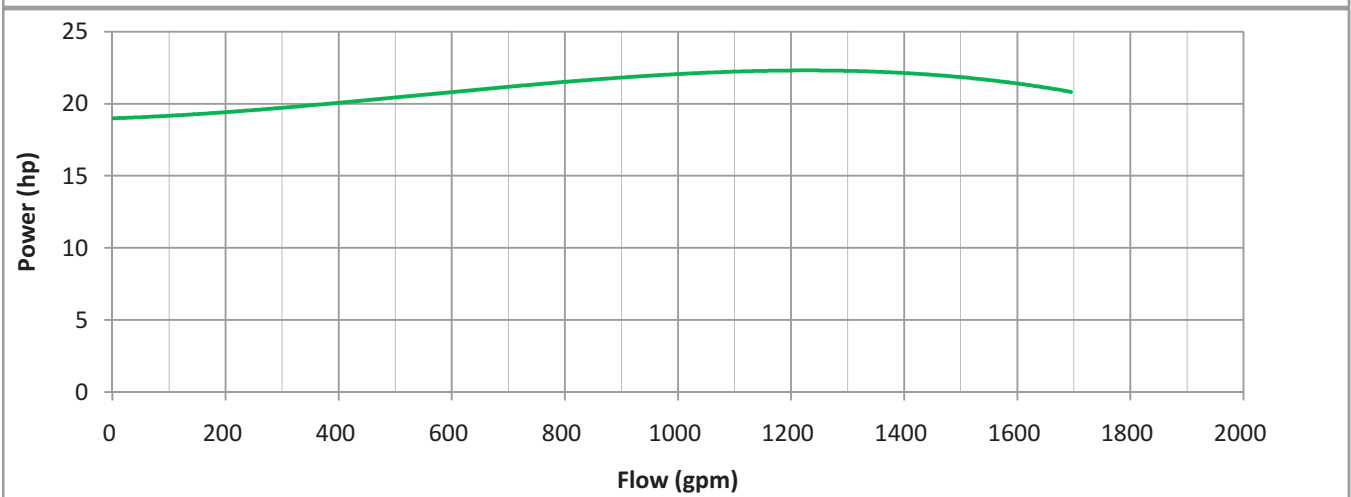
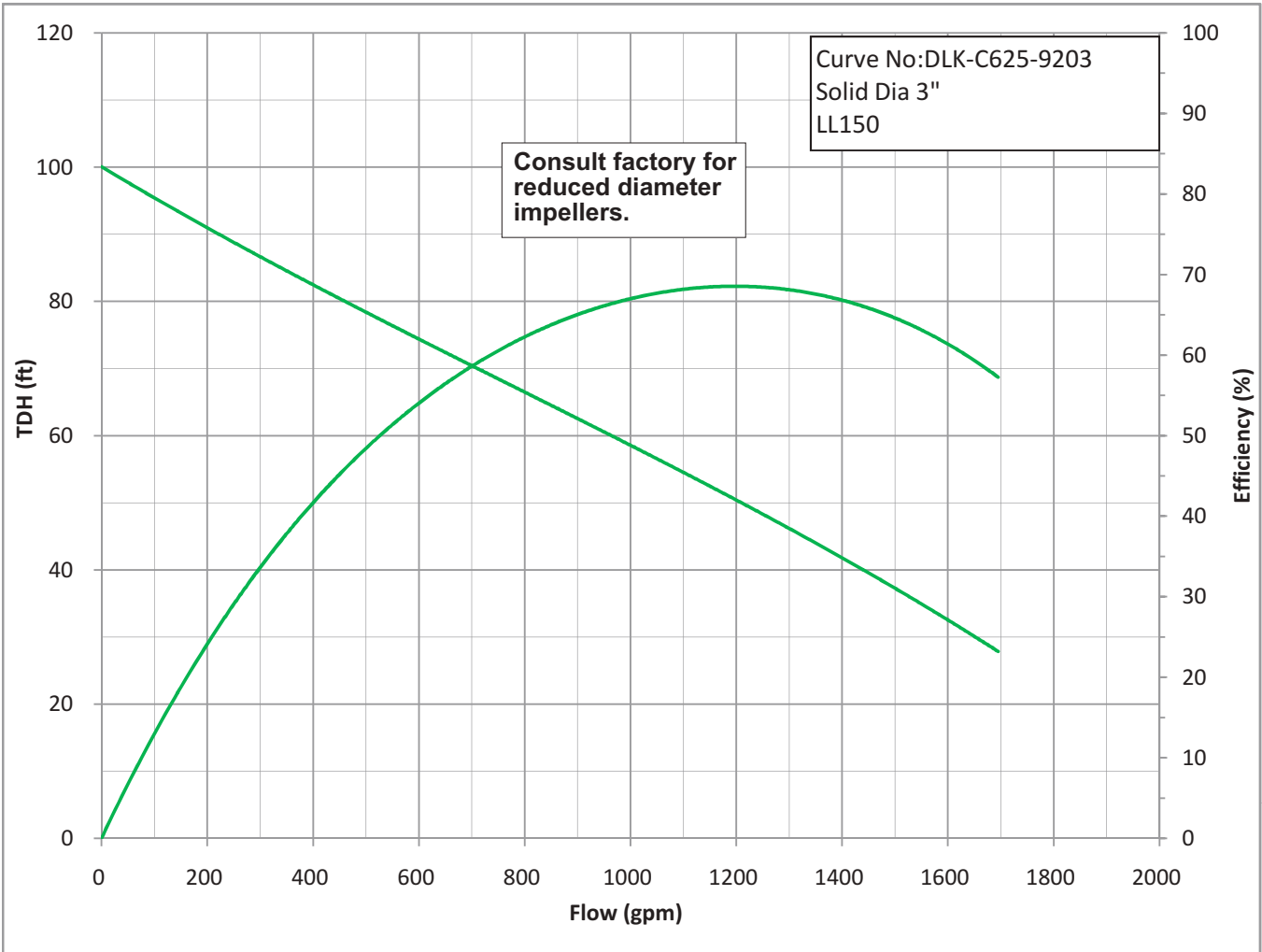

Performance Curves

Project: \_\_\_\_\_ GPM: \_\_\_\_\_ TDH: \_\_\_\_\_ EFF: \_\_\_\_\_ HP: \_\_\_\_\_ Chk'd: \_\_\_\_\_ Date: \_\_\_\_\_

200DLKFU622 (30 HP)

Synchronous Speed 1800 RPM

6, 8 inch Discharge

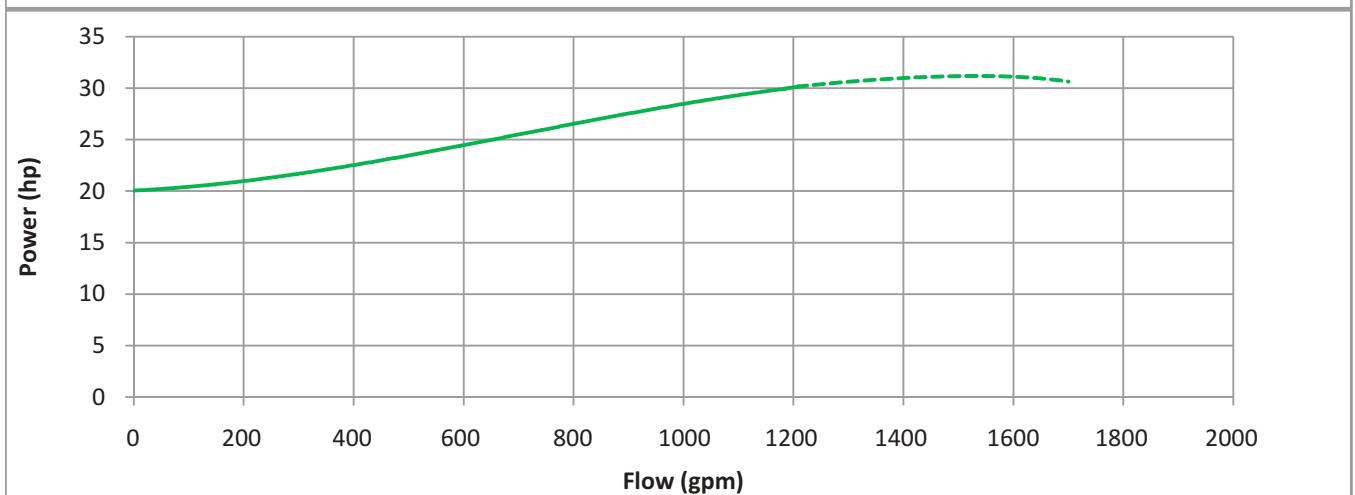
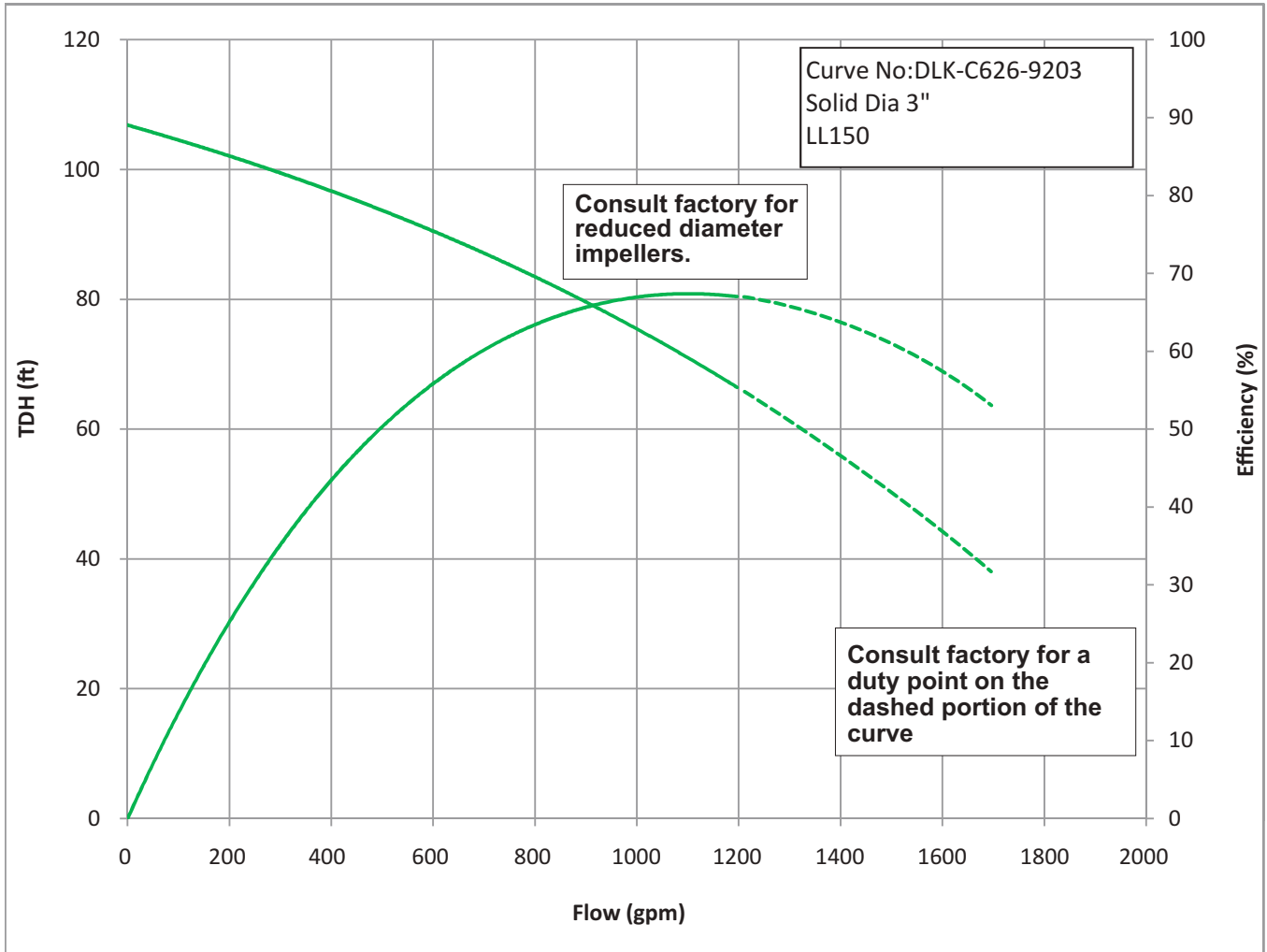

Performance Curves

Project: \_\_\_\_\_ GPM: \_\_\_\_\_ TDH: \_\_\_\_\_ EFF: \_\_\_\_\_ HP: \_\_\_\_\_ Chk'd: \_\_\_\_\_ Date: \_\_\_\_\_

250DLKFU611 (25 hp)

Synchronous Speed 1800 RPM

10 inch Discharge

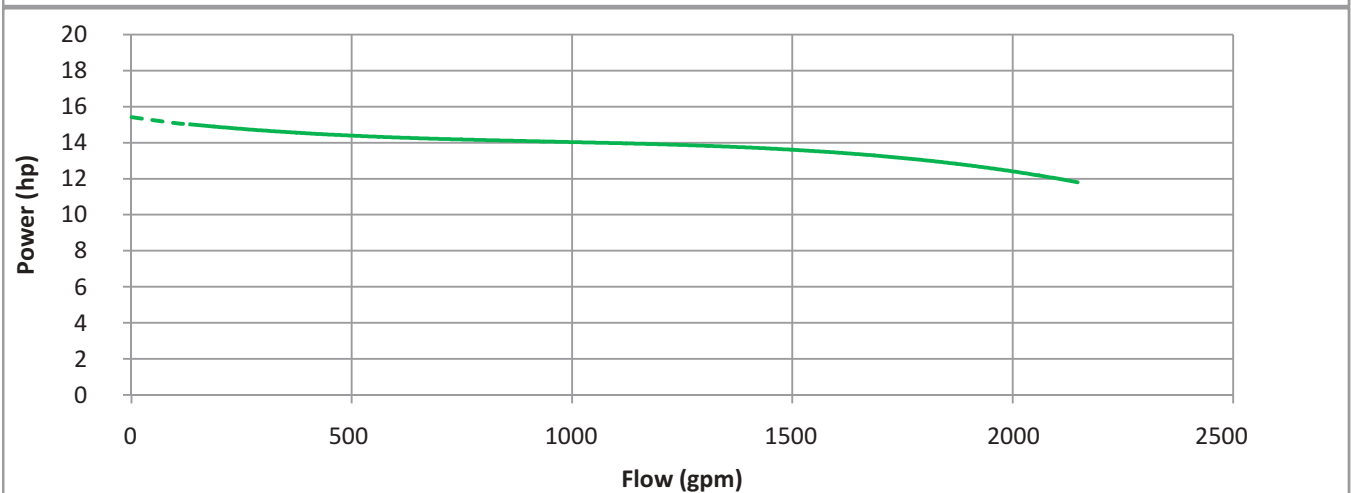
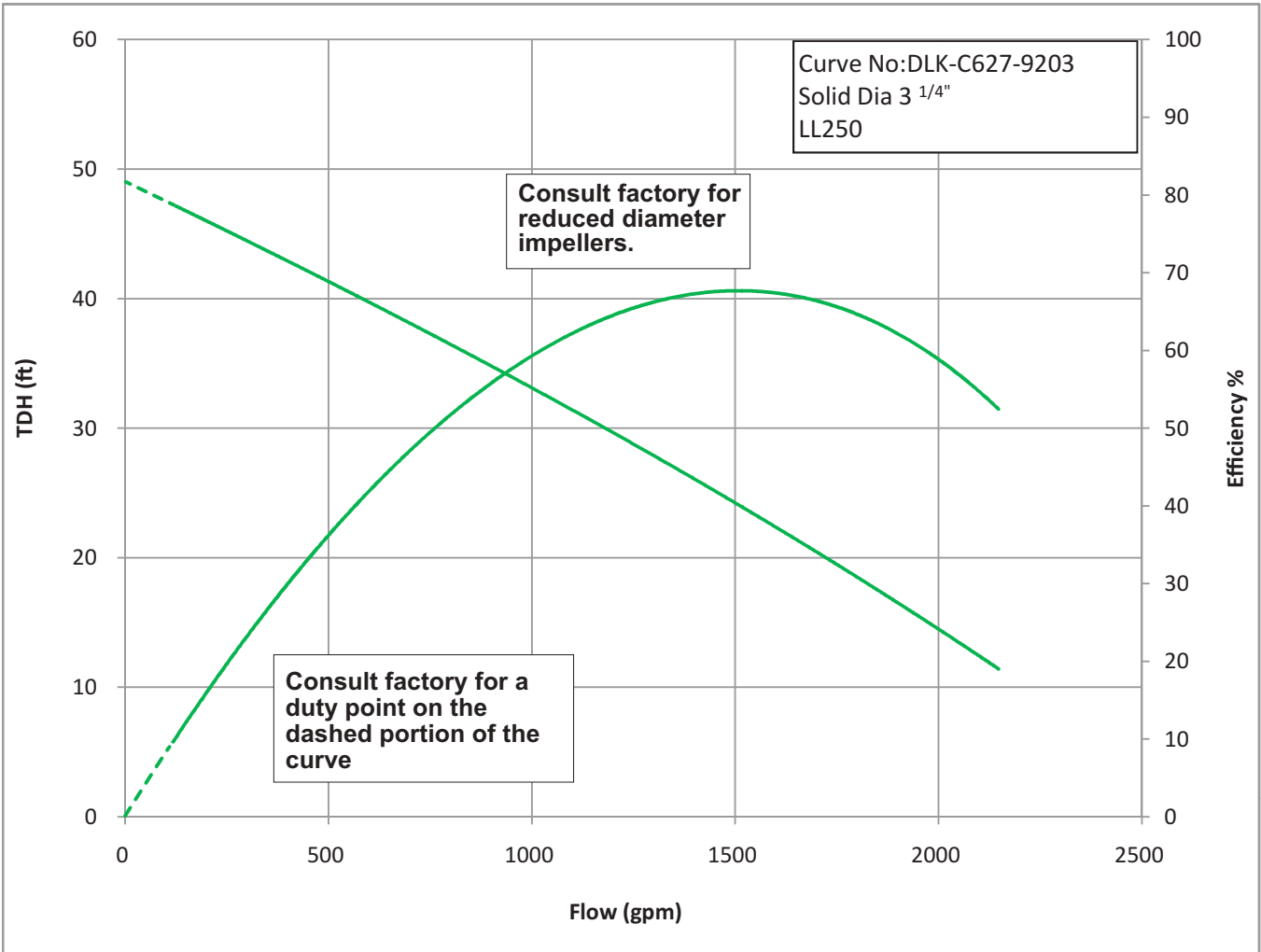



Performance Curves

Project: \_\_\_\_\_ GPM: \_\_\_\_\_ TDH: \_\_\_\_\_ EFF: \_\_\_\_\_ HP: \_\_\_\_\_ Chk'd: \_\_\_\_\_ Date: \_\_\_\_\_

250DLBKFU615 (20 hp)

Synchronous Speed 1800 RPM

10 inch Discharge

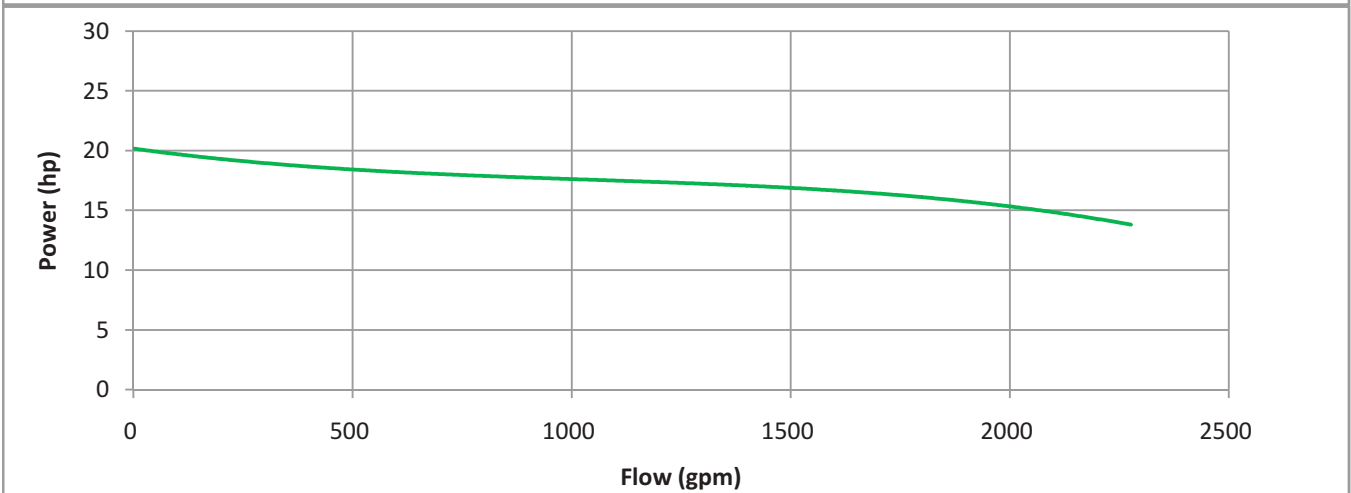
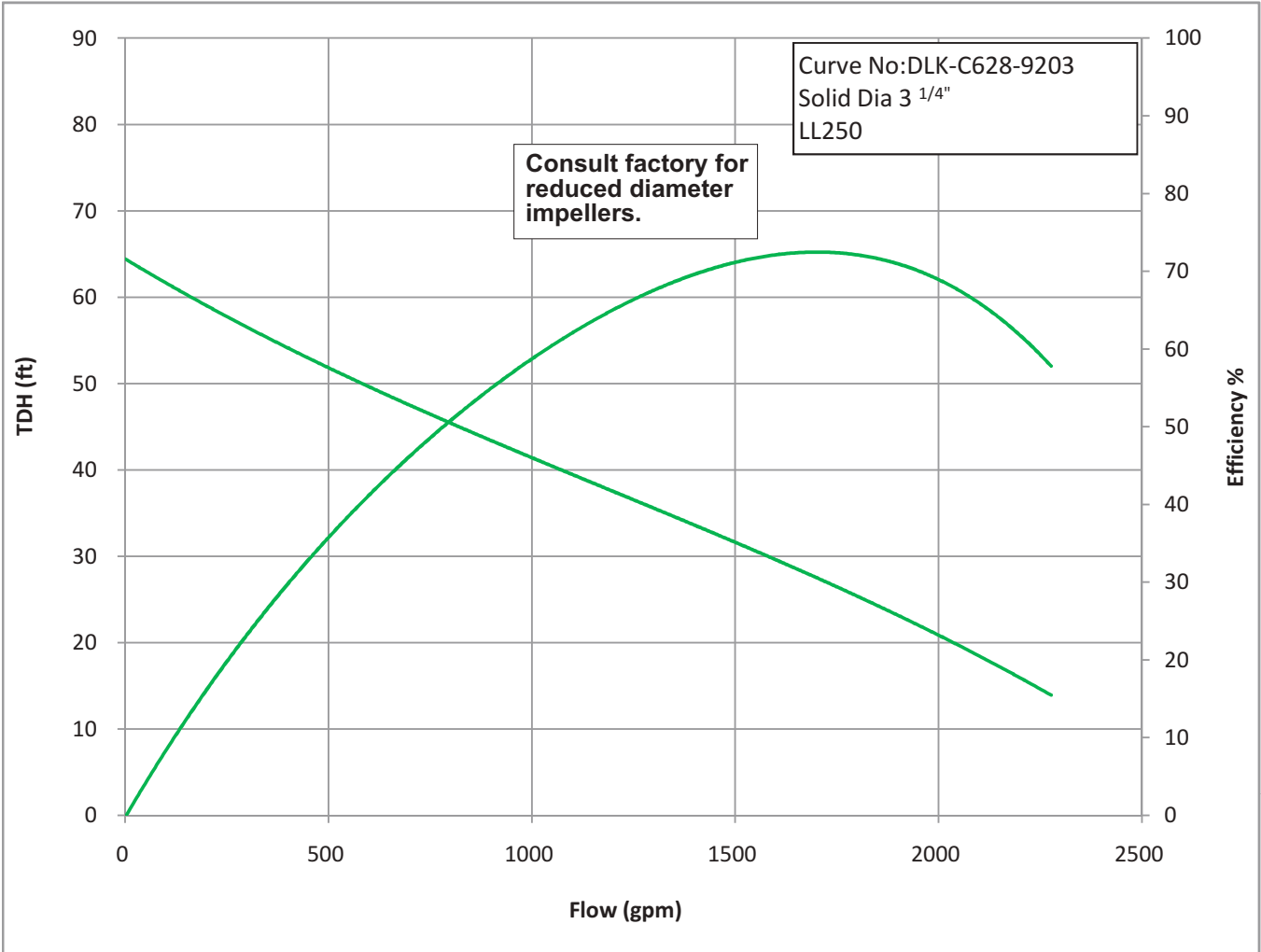

Performance Curves

Project: \_\_\_\_\_ GPM: \_\_\_\_\_ TDH: \_\_\_\_\_ EFF: \_\_\_\_\_ HP: \_\_\_\_\_ Chk'd: \_\_\_\_\_ Date: \_\_\_\_\_

250DLCKFU615 (20 HP)

Synchronous Speed 1800 RPM

10 inch Discharge

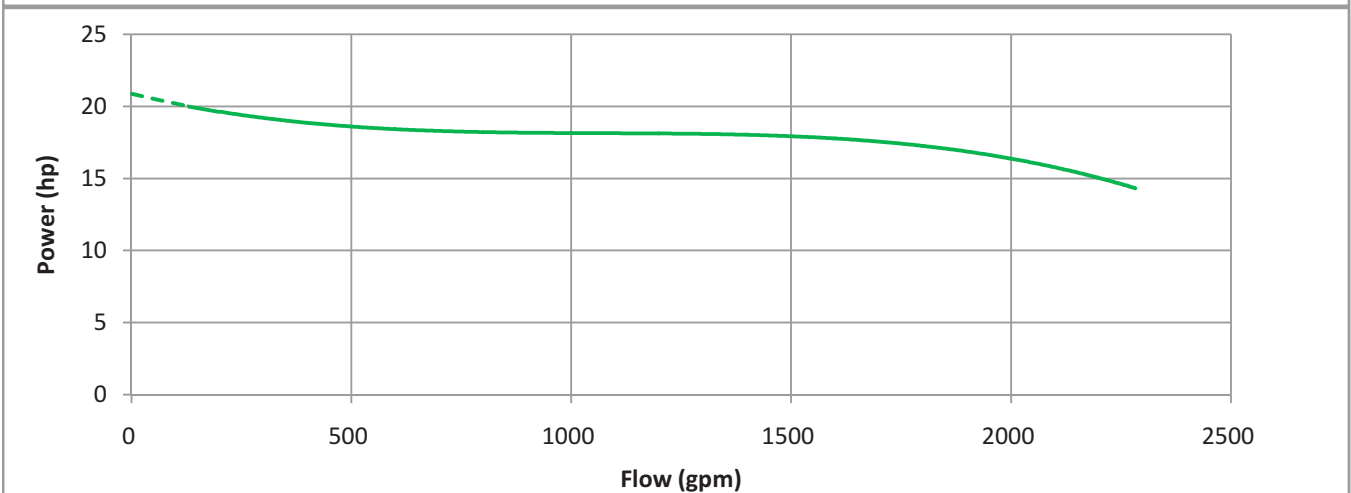
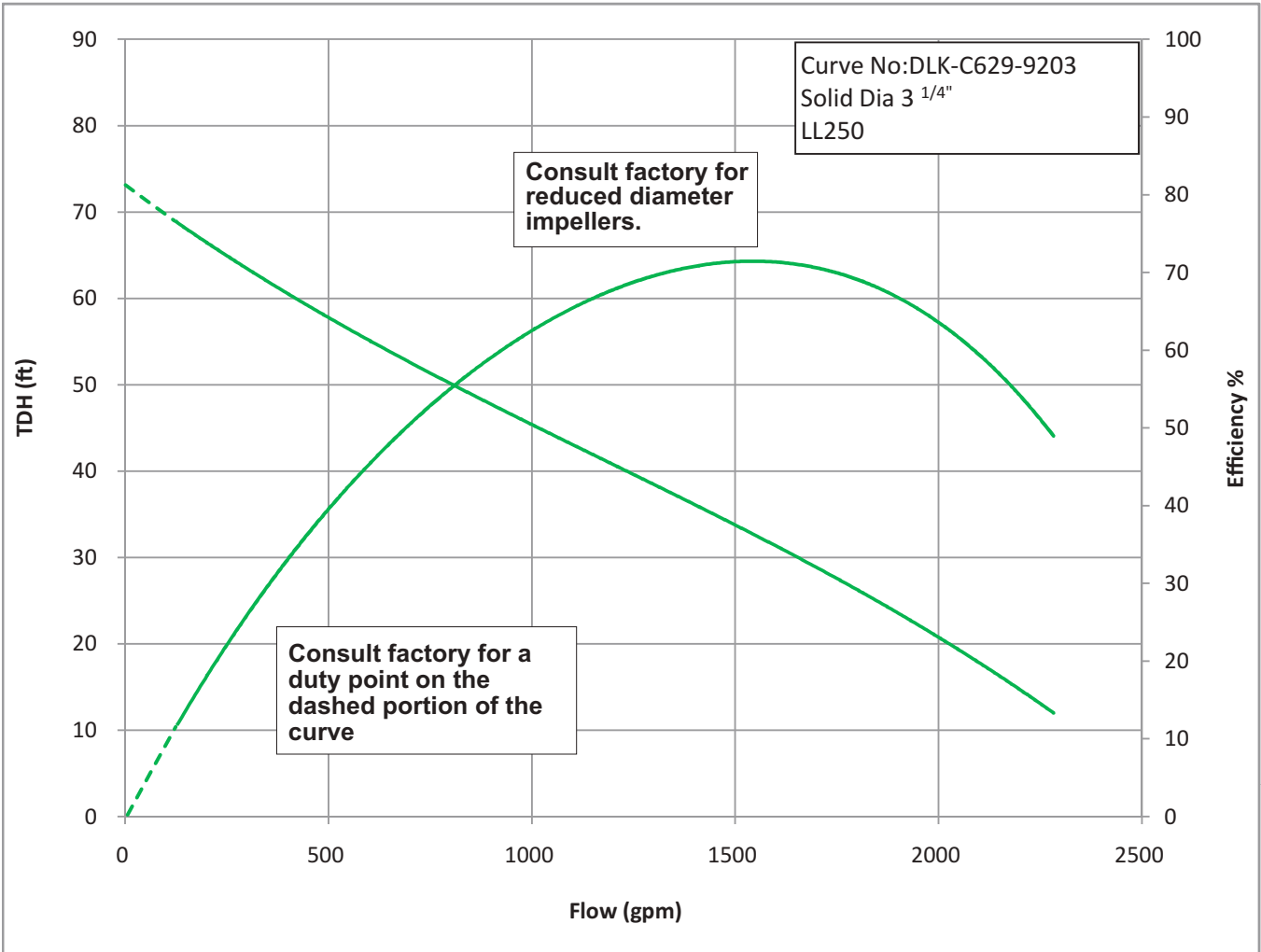

Performance Curves

Project: \_\_\_\_\_ GPM: \_\_\_\_\_ TDH: \_\_\_\_\_ EFF: \_\_\_\_\_ HP: \_\_\_\_\_ Chk'd: \_\_\_\_\_ Date: \_\_\_\_\_

250DLKFU618 (25 HP)

Synchronous Speed 1800 RPM

10 inch Discharge

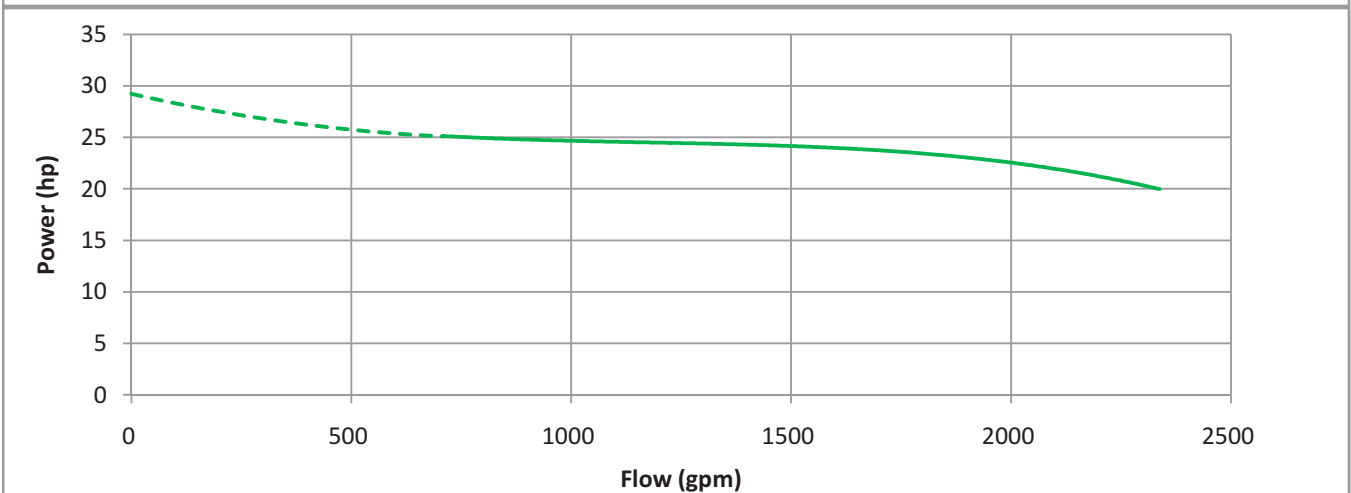
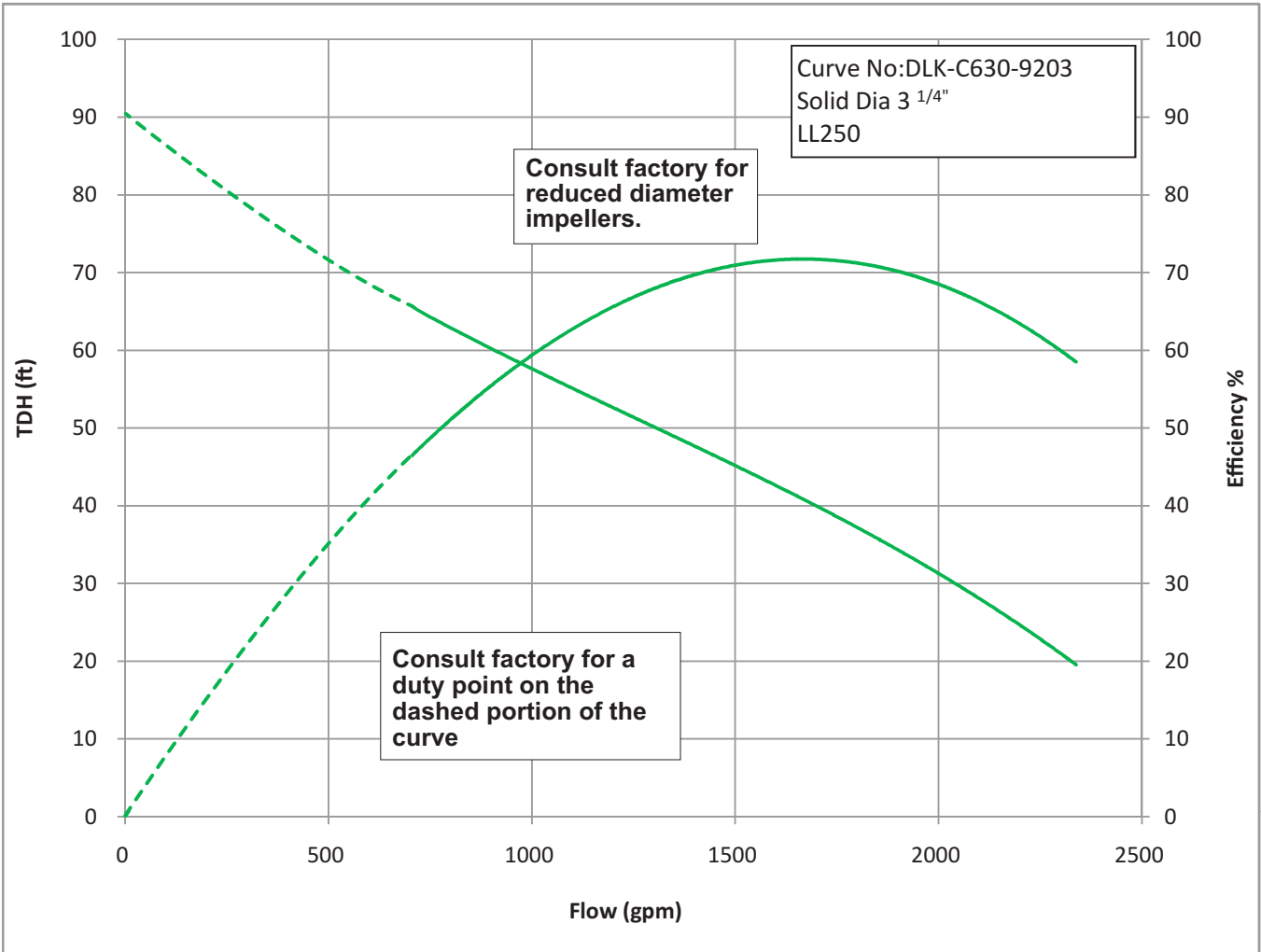

Performance Curves

Project: \_\_\_\_\_ GPM: \_\_\_\_\_ TDH: \_\_\_\_\_ EFF: \_\_\_\_\_ HP: \_\_\_\_\_ Chk'd: \_\_\_\_\_ Date: \_\_\_\_\_

250DLKFU622 (30 HP)

Synchronous Speed 1800 RPM

10 inch Discharge

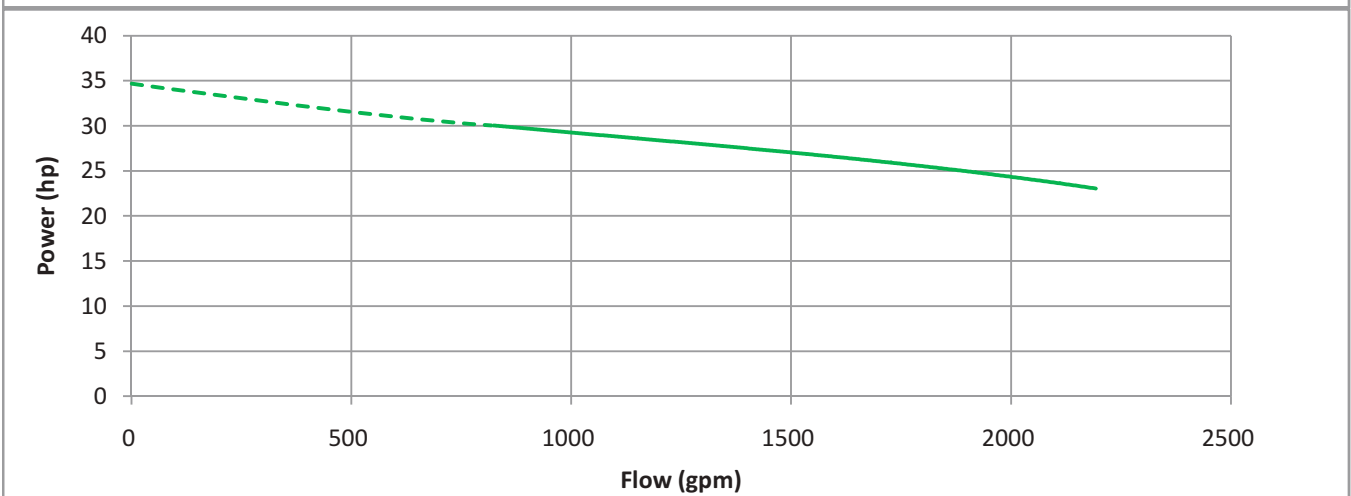
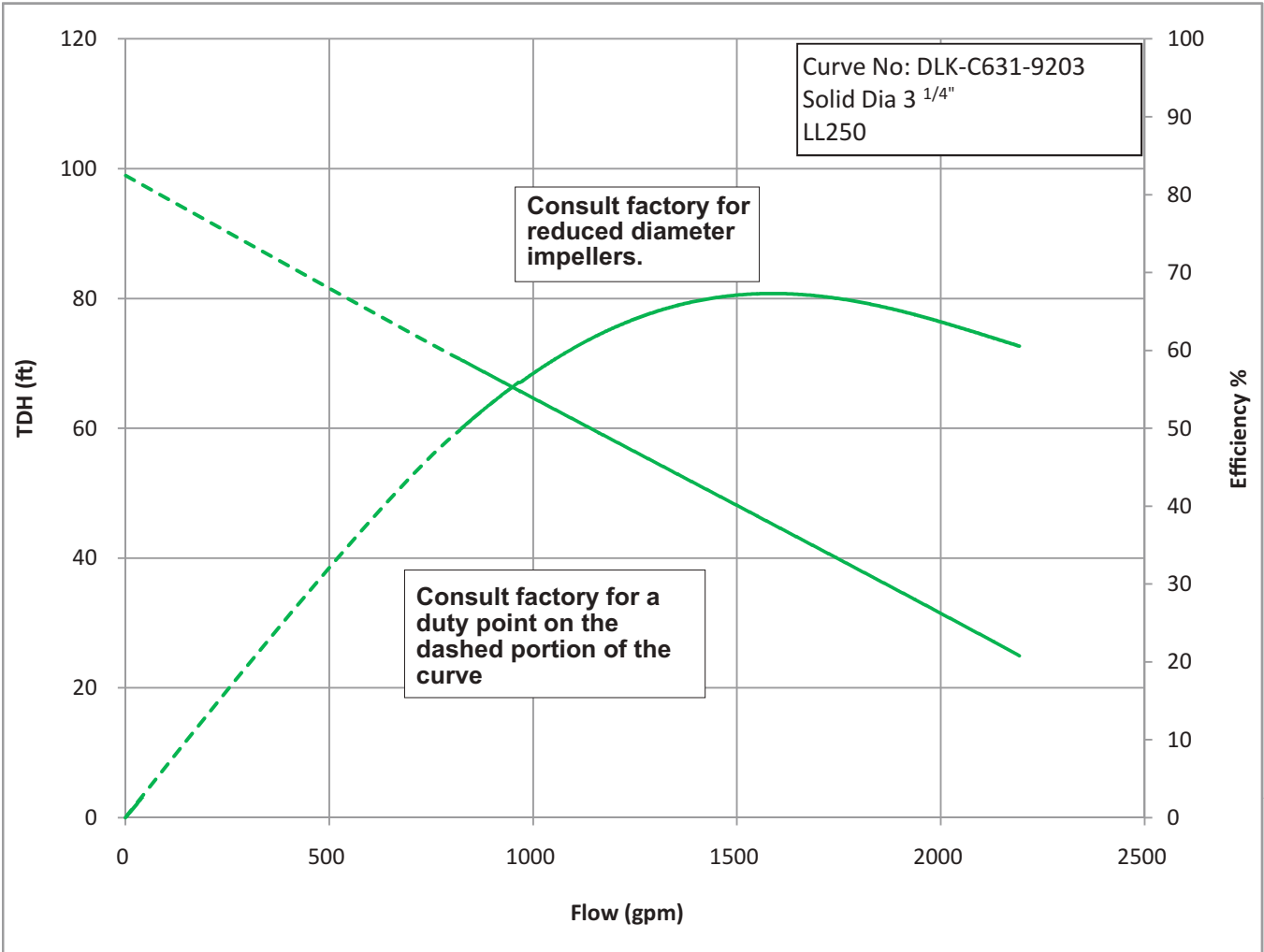

Performance Curves

Project: \_\_\_\_\_ GPM: \_\_\_\_\_ TDH: \_\_\_\_\_ EFF: \_\_\_\_\_ HP: \_\_\_\_\_ Chk'd: \_\_\_\_\_ Date: \_\_\_\_\_

300DLKFU618 (25 HP)

Synchronous Speed 1800 RPM

12 inch Discharge

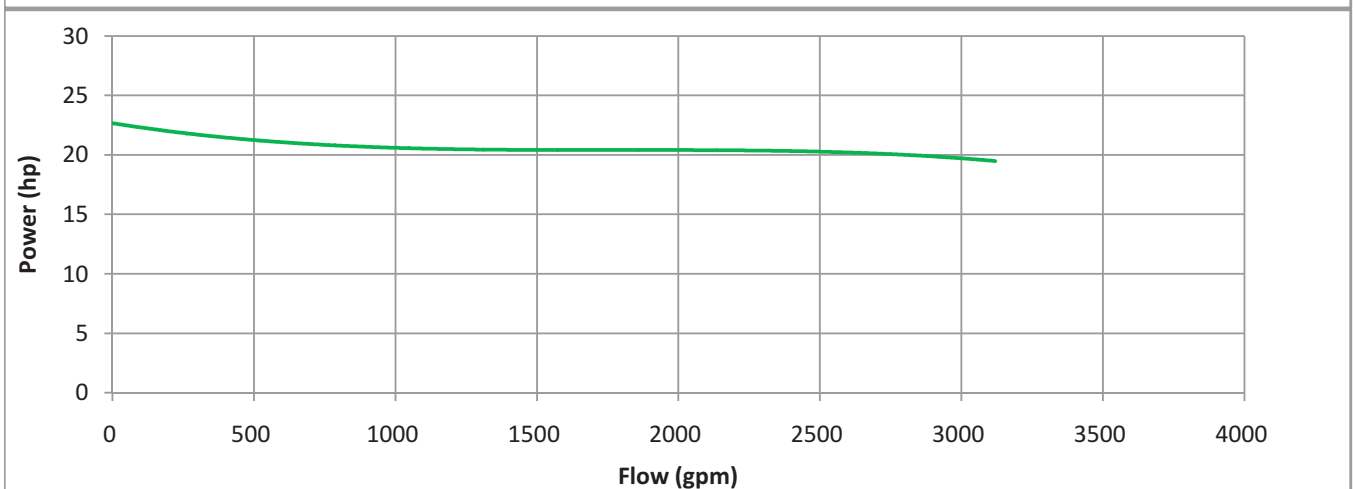
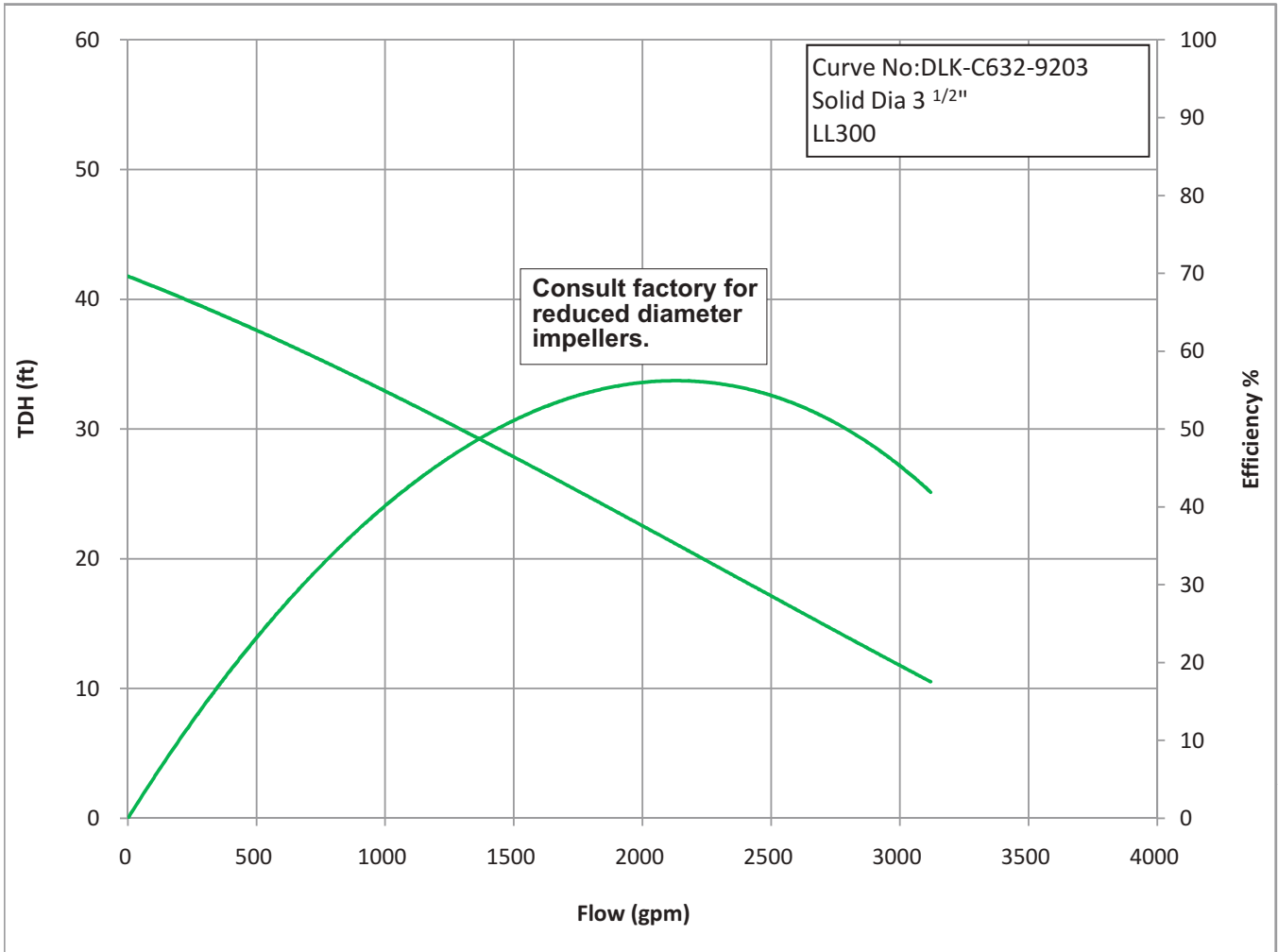

Performance Curves

Project: \_\_\_\_\_ GPM: \_\_\_\_\_ TDH: \_\_\_\_\_ EFF: \_\_\_\_\_ HP: \_\_\_\_\_ Chk'd: \_\_\_\_\_ Date: \_\_\_\_\_

300DLKFU622 (30 HP)

Synchronous Speed 1800 RPM

12 Inch Discharge

