Submersible Wastewater, Sewage Pump

Model DSC4, DSCA4



Operating Instructions, Installation & Maintenance Manual



EBARA Fluid Handling

EBARA International Corporation

1. Preface

Design of this EBARA pump is based on superior engineering and long experience. To prevent trouble and provide satisfactory operation and long life, it is important to understand the EBARA pump thoroughly by careful study of this manual. If any questions arise regarding this manual, please direct them to EBARA. Your questions will be promptly answered and your suggestion may be considered for incorporation into our future products.

⚠ CAUTION : *THIS INSTRUCTION MANUAL INCLUDES NECESSARY ITEMS FOR INSTALLATION, OPERATION AND MAINTENANCE. READ THIS MANUAL CAREFULLY TO ENSURE CORRECT INSTALLATION, OPERATION AND MAINTENANCE.*

BE SURE TO KEEP THIS INSTRUCTION MANUAL ON HAND FOR FUTURE REFERENCE.

Safety Labels

Four different types of safety labels are used in this manual. Please study the labels carefully so that the meaning of any safety warning you encounter is immediately clear.

⚠ DANGER : indicates a potentially hazardous situation which, if not avoided, will result in death or serious injury.

⚠ WARNING : indicates a potentially hazardous situation which, if not avoided, could result in death or serious injury

⚠ CAUTION : indicates a potentially hazardous situation which, if not avoided, may result in minor or moderate injury or possible damage to the equipment or machine.

Note : is used to call attention or to emphasize essential information.

2. Acceptance Inspection

Upon arrival of the pump –

- (1) Check the nameplate information for agreement with specifications in respect to model identification, head, pumping capacity, speed, output, voltage and frequency.
 - (2) Check the pump has not been damaged during shipment and all plugs and fastening bolts properly tightened.
 - (3) Check accessories and spare parts against the packing list.
- If any problem is found, contact your dealer.

3. Installation

3.1 Foundation

Place concrete to build up the floor and discharge elbow foundations to the values shown in installation drawing. The discharge elbow foundation must have sufficient size and strength to support the weight of the pump body, submersible motor and accessories plus the weights of the discharge pipe, and to absorb vibrations and impacts resulting from operation. Usually, it should weigh more than seven times the pump weight.

3.2 Floor Frame (Fig. 1, 2 and 3)

Install a cable lead-out elbow and a floor frame on the floor over the pump pit. Attach a guide pipe holder securely to the floor frame with bolts. As the guide pipe must be installed vertically (with a tolerance of 1mm (0.04in) or less per 1m (3.3ft)), carefully check the positional relationship between the floor frame location and the discharge elbow foundation. (See Fig. 1 *)

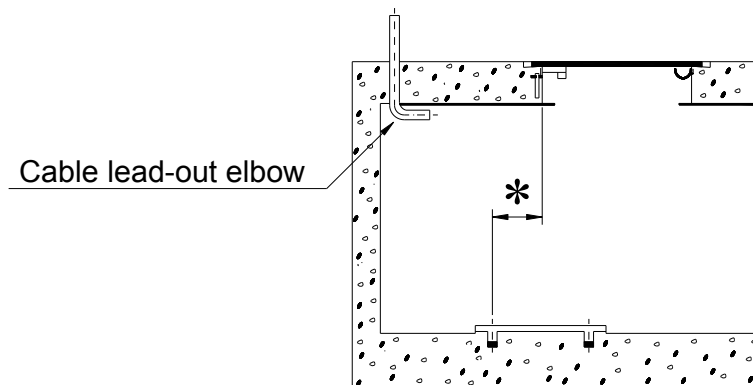
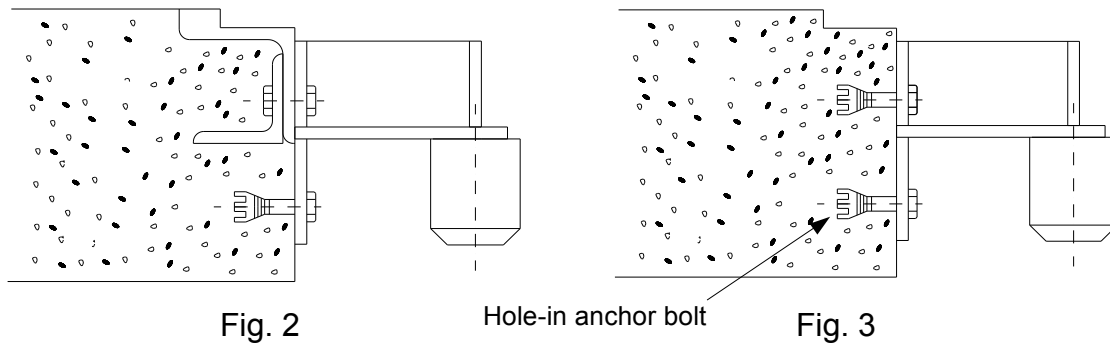

Fig. 1

If the guide pipe holder is attached directly to the concrete, use hole-in anchor bolt as shown in Fig. 3.



⚠ CAUTION : IF THE CABLE LEAD-OUT ELBOW IS TOO SMALL IN DIAMETER, THE CABLE MAY BE HEATED WHERE IT RUNS THROUGH THE ELBOW.

3.3 Discharge Elbow Installation (Fig. 4)

⚠ WARNING : WHEN LIFTING THE PUMP, USE APPROPRIATE CRANE (OR HOIST) AND LIFT SYSTEM. CHECK POSITION AND TIGHTNESS OF LIFT SYSTEM SO THAT WEIGHT OF THE PUMP IS NOT UNBALANCED. FAILURE TO OBSERVE THIS PRECAUTION CAN RESULT IN SERIOUS ACCIDENTS.

Install the discharge elbow level on the bottom on the pump pit, and connect the guide pipe.

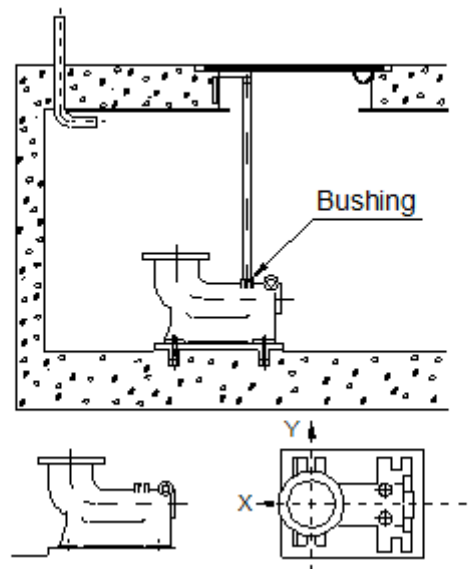

Fig 4

Support the guide pipe with bushings on discharge elbow and the guide pipe holder. If the guide pipe requires a length exceeding 5.5m (18ft), an extension or intermediate support may become necessary, in which case we are available for consultation. When installing the discharge elbow, the guide pipe must be vertical (with a tolerance of 1mm (0.04in) or less per 1m (3.3ft)), using a plum bob. If it is not vertical, it may become impossible to lift pump. Discharge elbow level should be within 0.1mm (0.04in) per 1m (3.3ft), both in the “X” and “Y” directions shown in Fig. 4. It is recommended practice that pipe installation be carried out with the discharge elbow covered to protect against entry of concrete and mortar during the work.

⚠ CAUTION : *FIX THE ANCHOR BOLTS TIGHTLY BY, FOR EXAMPLE, BY WELDING THEM TO THE REINFORCEMENT BAR, ETC.*

3.4 Discharge Pipe Installation (Fig. 5)

When mortar under discharge elbow has been sufficiently set, proceed with piping to the discharge side.

⚠ CAUTION : *DURING THIS WORK, TAKE CARE NOT TO SUBJECT THE DISCHARGE ELBOW TO EXCESSIVE WEIGHTS.*

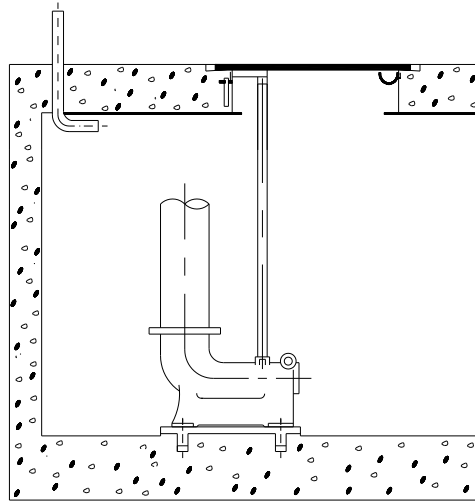

Fig. 5

3.5 Water Level Switch Installation (Fig. 6)

Install a water level switches for use during automatic operation. If a float type switch is used, each pump will required a total of 3 (or 4) for starting, stopping, (low level alarm) and high-level alarm.

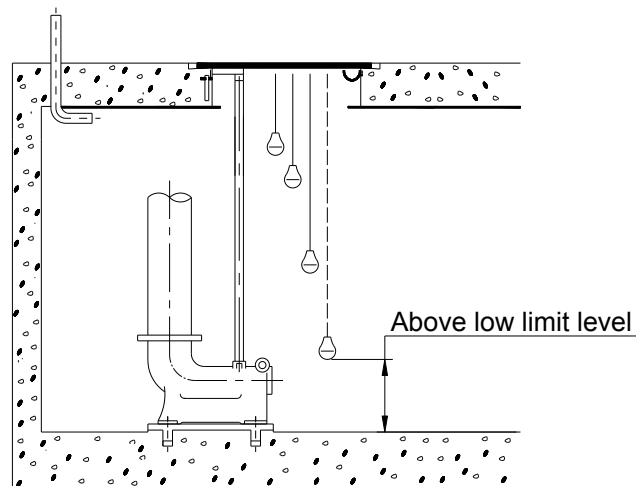

Fig. 6

3.6 Check the Followings Points (1) through (6) Prior to Pump Installation

- (1) Ensure that the mechanical seal chamber is filled with specified amount of oil.

***ICS opt.**

Ensure that the coolant chamber is filled with specified amount of coolant.

- (2) All plugs and fastening bolts are properly tightened.
- (3) The sealing chamber is not leaking.
- (4) The pump is not damage and the cable glands and cables are in satisfactory condition.
- (5) Insulation resistance values are within limits. (See 3.6.2)
- (6) Other points that require particular attention. (See 3.6.3)

3.6.1 Oil Supply (Fig. 7, 8 and 9)

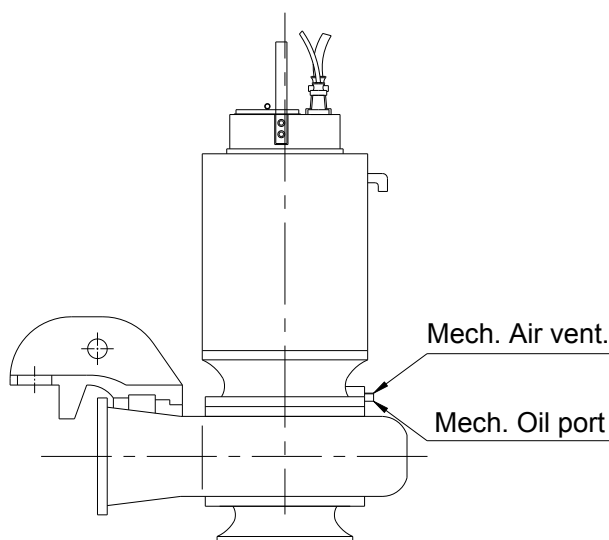

Fig. 7

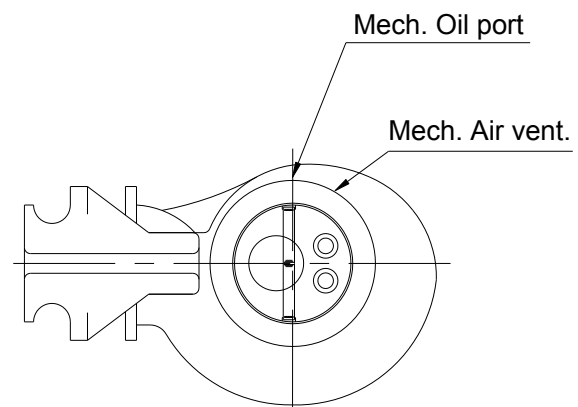

Fig. 8

The motor shaft is sealed with a tandem mechanical seal. The seal chamber provide between the two sealing stages can be filled with turbine oil by standing the pump vertically and unplugging “oil port” and “air vent”.

⚠ CAUTION : THE SEAL CHAMBER MAY BE UNDER PRESSURE. HOLD A RAG OVER THE OIL PLUG TO PREVENT SPLATTER.

Pour the specified oil into the sealing chamber through the “oil port” until the oil flows out of the “air vent”. (See Table 1)

After the sealing chamber is filled to the specified level, put a sheet gasket between the plug and the boss, and tighten the plug.

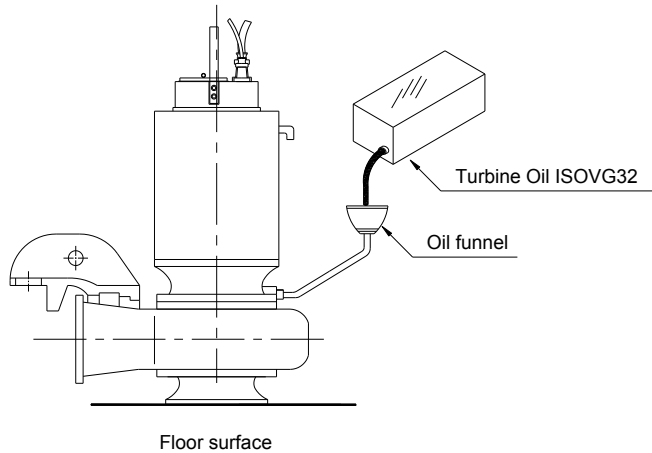

Use one of the following oils or equivalent.

Shell	: Turbo oil T32
Mobil	: Mobil DTE oil light
Esso	: Esso Tresso 32
Exxon	: Teresstic 32
Gulf	: Harmony 32, Crest 32
Caltex	: Rega Oil R&O 32

• • • • Fig. 9

Table 1

Pump Model	Model Code	Approx. Oil Capacity (liter)	Pump Model	Model Code	Approx. Oil Capacity (liter)
150DSC4	AC-46050 AO-46050	2.4	300DSC4	FC-66050 FO-66050	2.4
	AC-46060 AO-46060			FC-66060 FO-66060	
	AC-46075 AO-46075	GC-66075 GO-66075		2.3	
	BC-46100	EEC-66175		5.2	
	BC-46120	EEC-66200			
	CC-46120	EEC-66215			
	CC-46145	3.2	400DSC4	EEC-66245	4.5
	CC-46175			D1C-106050	
	HC-46050 HO-46050	3.2	D1C-106060	5.5	
	HC-46060 HO-46060		D1C-106075		
	HC-46075 HO-46075		4.3	500DSC4	D2C-1060100
	C1C-46175			G1C-1060120	6.2
	C1C-46200	G1C-1060145			
	C1C-46215	G2C-860175			
C1C-46245	G2C-860200				
250DSC4	EC-66100 EO-66100	3.9		G2C-860215	
	EC-66120 EO-66120		G2C-860245		
	EC-66145 EO-66145				

***ICS opt. 3.6.1 Coolant Supply (Fig. 7c, 8c and 9c)**

Fig. 7c

Fig. 8c

The motor shaft is sealed with a mechanical seal. The coolant chamber provided between the two sealing stages can be filled with coolant by standing the pump vertically and unplugging “Coolant supply hole” and “Air vent & full level check hole”.

⚠ CAUTION : THE SEAL CHAMBER MAY BE UNDER PRESSURE. HOLD A RAG OVER THE PLUG TO PREVENT SPLATTER.

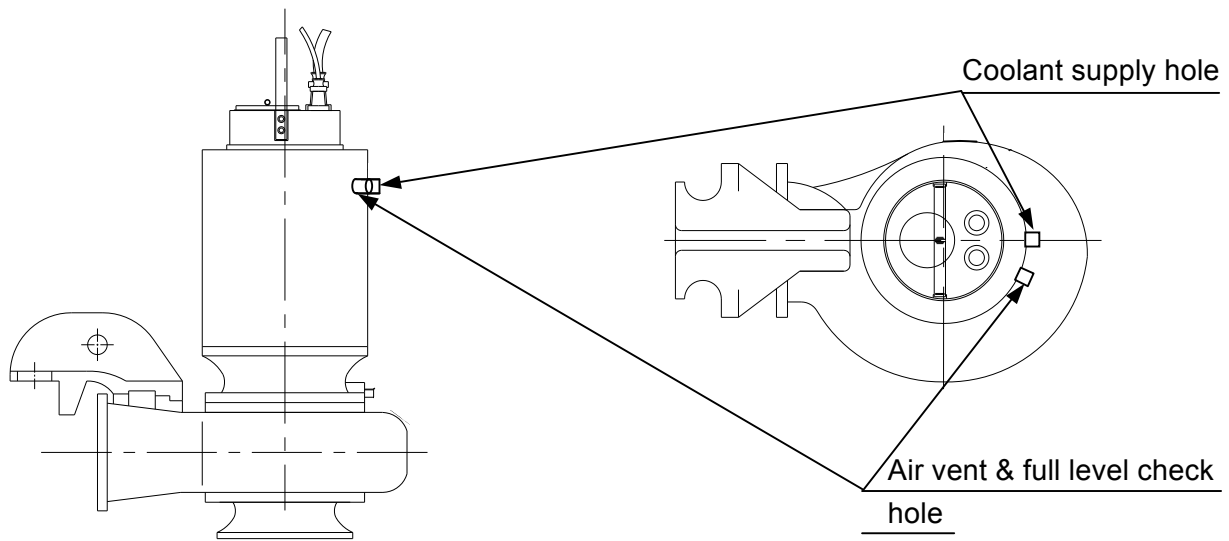
Pour the specified coolant into the coolant chamber through “Coolant supply hole” until the coolant flows out of “Air vent & full level check hole”. (See Table 1c)
After the coolant chamber is filled to the specified level, plug the two holes.

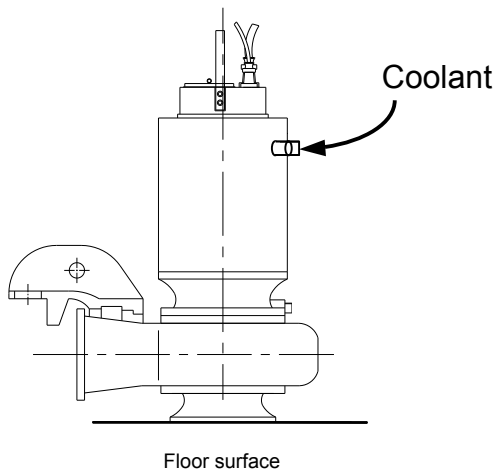

The ingredients of the coolant are to be as follows.

- 30% : Propylene glycol
- 70% : Water

◦ ◦ ◦ ◦ Fig. 9c

Table 1c

Pump Model	Model Code	Approx. Coolant Capacity (liter)	Pump Model	Model Code	Approx. Coolant Capacity (liter)
150DSC4C	AC-46050	51	250DSC4C	EC-66100	69
	AO-46050			EO-66100	
	AC-46060	57		EC-66120	73
	AO-46060			EO-66120	
	AC-46075	60		EC-66145	80
	AO-46075			EO-66145	
	BC-46100	66	300DSC4C	FC-66050	57
	BC-46120	60		FO-66050	
	CC-46120	60		FC-66060	60
	CC-46145	68		FO-66060	
HC-46050	52		GC-66075	60	
HO-46050			GO-66075		
HC-46060	58				
HO-46060					
HC-46075	61				
HO-46075					

3.6.2 Insulation Resistance Measurement

⚠ WARNING : ALL ELECTRIC WORK SHOULD BE PERFORMED BY A QUALIFIED ELECTRICIAN AND ALL NATIONAL AND LOCAL ELECTRICAL CODES MUST BE OBSERVED.

Although insulation resistance of this pump has been shop tested, it should be rechecked prior to installation, using the following procedure. Usually, insulation resistance of a minimum of 50MΩ is considered satisfactory (when measured with a DC 500V Megger).

Measurement procedure (Refer to Figs. 10 and 11)

Connect the minus (-) terminal to G of the DC 500V Megger to the G terminal of the power cable, or a motor bolt.

In dual power cable, connect the L4-, L5- and L6- phases electrically and keep them off the ground.

Touch the plus (+) terminal of the Megger to L1-phase (or L2-phase or L3-phase) of the power cable, and read the insulation resistance.

Touch the plus (+) terminal of the Megger to P1 (or P2) and P3 (or P4) of the protective device cable, with the minus (-) terminal G connected as above, and read the insulation resistance.

⚠ CAUTION : DO NOT CONNECT THE TWO MEGGER TERMINALS BETWEEN P1 AND P2 OR P3 AND P4, TO AVOID DAMAGE TO THE PROTECTIVE DEVICE. KEEP THE CABLES OFF THE GROUND WHILE TAKING ALL MEASUREMENTS.

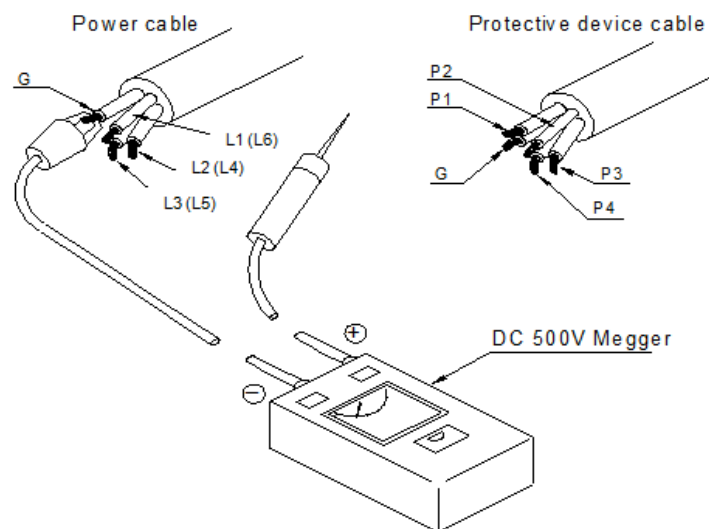
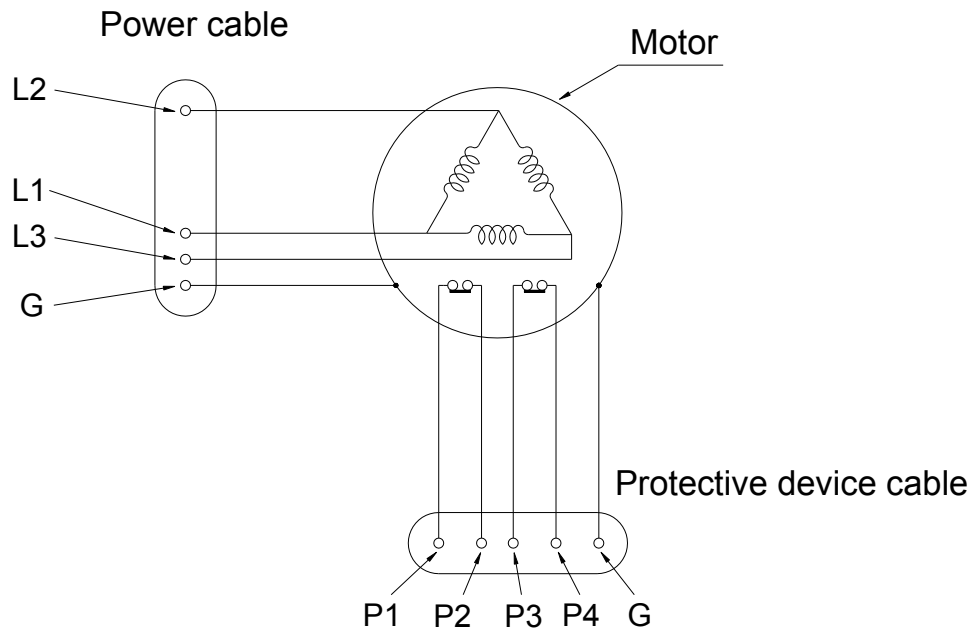

Fig. 10

***Single Power Cable (50HP – 175HP models)**



***Dual Power Cable (200HP - 245HP models)**

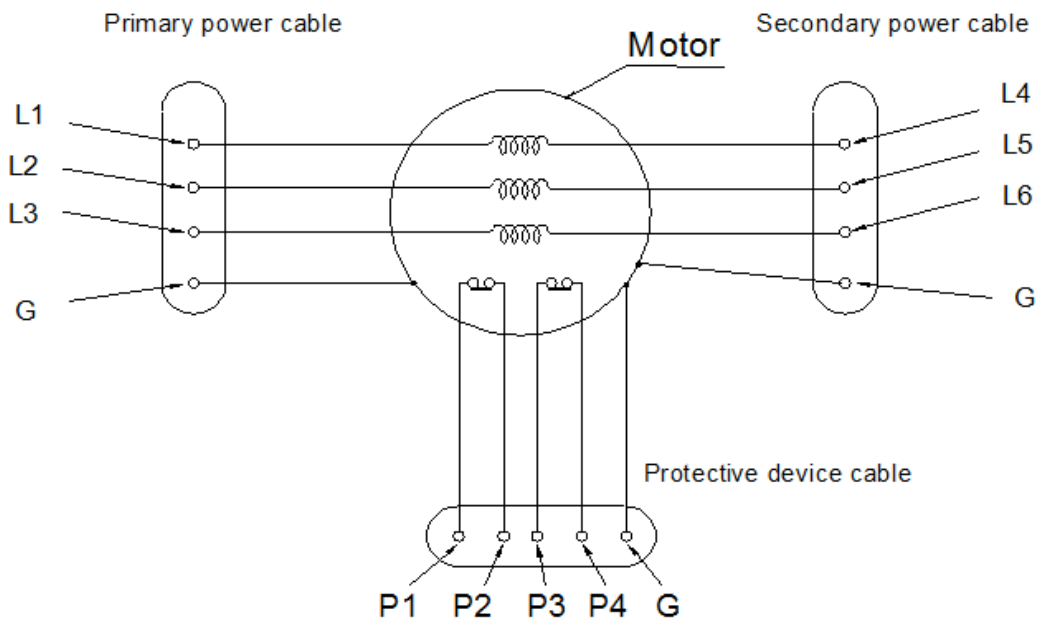

Fig. 11

3.6.3 Other Checks Requiring Particular Attention

(1) Minimum operating water level

Be sure that the pump stop level is not lower than the minimum operating water level specified in the technical document. If the stop level is lower, a vortex flow can occur causing the pump to intake air, resulting in noise and vibration.

If there is possibility that the minimum water level may decrease to an excessive extent, it is necessary to use a minimum water level alarm. An alternative measure would be a water level-dependent automatic control system where the motor is turned off to automatically stop the pump with the water lowered to a critical level and is turned on again to resume automatic operation when water is restored to a safe level.

(2) Pump location relative to pump pit water inlet

If the pump is installed near the pump pit water inlet, it can be considerably disturbed; it can be shaken and the cables whipped by vigorous inlet water, resulting in damage. Therefore, the pump should be located as far from the water inlet as possible.

(3) Size of debris

Entry of large or long debris can result in a blocked impeller.

If such problem actually occurs, the pump can be readily lifted out and disassembled for servicing, which is however, time and labor consuming.

The primary consideration therefore should be to prevent the ingress of any oversized objects into the sump by use of a screen, etc. Another important consideration is to minimize presence of abrasive substances, such as sand, in the liquid.

If the contents of such substances becomes high, the impeller is increasingly worn, leading to the degradation of capacity.

Note : In case any problem as above actually takes place, contact us immediately.

3.7 Pump Installation (Fig. 12)

⚠ WARNING : WHEN LIFTING THE PUMP, USE APPROPRIATE CRANE (OR HOIST) AND LIFT SYSTEM. CHECK POSITION AND TIGHTNESS OF LIFT SYSTEM SO THAT WEIGHT OF THE PUMP IS NOT UNBALANCED. FAILURE TO OBSERVE THIS PRECAUTION CAN RESULT IN SERIOUS ACCIDENTES.

After the pump has been thoroughly checked to verify that it is in order, lift the pump body and fit the sliding guide of the pump body to the guide pipe. Then, lower the pump body slowly along the pump guide.

The pump is automatically connected to the discharge elbow.

If the pump cannot be slid down smoothly, the guide pipe may not be vertical or the lifting method may be wrong. Check these points to determine the cause for correction.

After the pump is installed attach the chain to the hook of the floor frame.

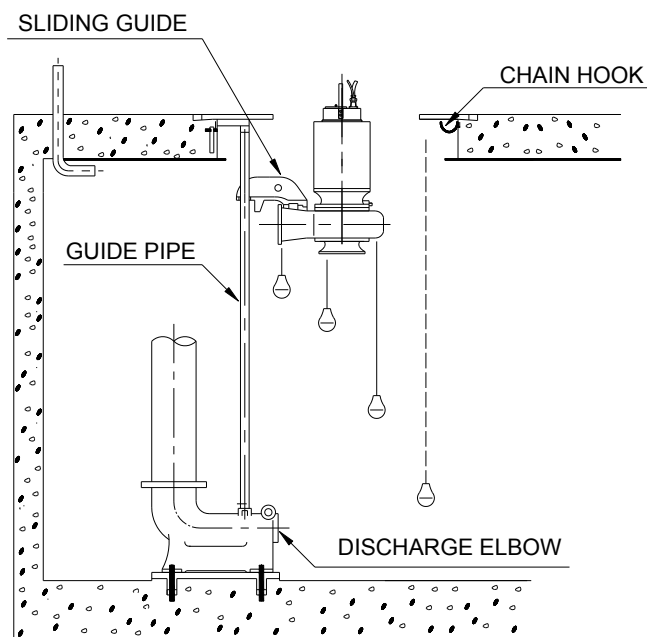

Fig. 12

When the pump is installed indoors, it should be a good idea for convenience's sake that a hoist, for example, be provide on the ceiling so that it can be moved to the pump lifting center when necessary.

3.8 Cable Installation (Fig. 13)

When the pump has been installed, pull out the power cable, protective device cable, water level switch cable, etc. from the cable lead-out elbow on the floor and connect them to the control panel.

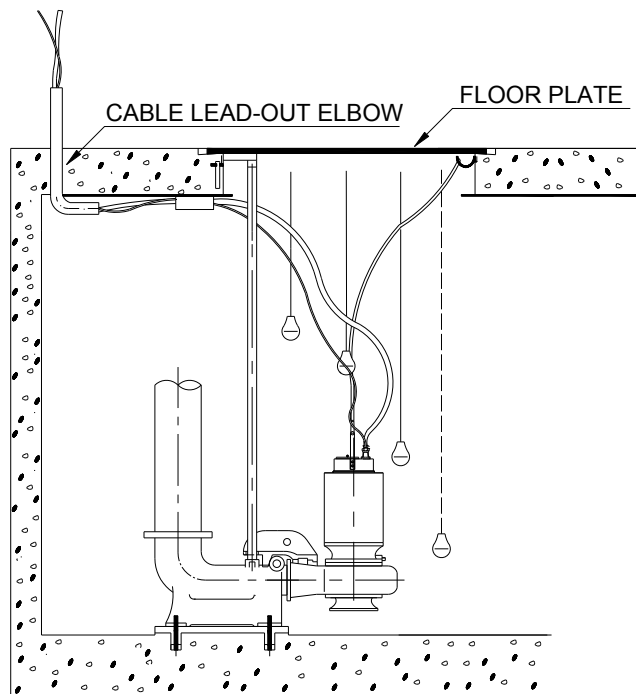

Fig. 13

⚠ CAUTION : HANDLE THE CABLES VERY CAREFULLY. IF THEY ARE BENT OR PULLED EXCESSIVELY, THE CABLE AND THE MOLDED SEAL MAY BE DAMAGED, RESULTING IN INSULATION FAILURE. ALSO, CARE IS NEEDED TO PROTECT CABLE ENDS AGAINST WATER INTRUSION.

Note : The cables should be cut to the necessary length.

If the cable is too short, it can prevent lifting of the pump.

If the cable is too long and laid loose on the pump pit bottom, it could be sucked into the pump.

If left coiled on the ground, it could be locally heated.

3.9 Floor Plate

Finally, install the floor plate over the pump pit, and the installation work is finished.

4. Electric Wiring

4.1 Power Cable Connection

⚠ WARNING : CHECK THAT THE POWER IS LOCKED OFF AND DISCONNECTED BEFORE WORKING ON PUMP.

The electric wiring for a submersible motor is no different from that of an ordinary motor, except that the direction of rotation cannot be easily verified.

Wiring to wrong terminals results in a reversed motor, and to prevent this and to achieve best results, the following wiring procedure is recommended.

Connect terminals L1, L2, and L3 (and L4, L5 and L6 in dual power cable) to the secondary terminals L1, L2 and L3 (and L4, L5 and L6 in dual power cable) of the electromagnetic switch or breaker respectively. Connect the remaining terminal G to ground.

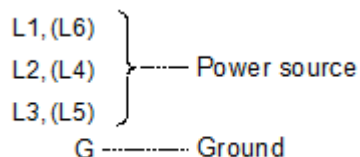

⚠ WARNING : WHEN PREPARING POWER CABLE LEADS FOR CONNECTION TO CONTROL, IT IS ESSENTIAL THAT THE GROUND LEAD BE LONGER THAN THE POWER LEADS. THE GROUND LEAD MUST HAVE AT LEAST 2" (50 MM) SLACK REMAINING AFTER CONNECTION, WHEN SPACE PERMITS. THIS IS DONE FOR ELECTRICAL SAFETY. IF THE CABLES IS MISTAKENLY PULLED OUT, THE GROUND LEAD WILL BE THE LAST WIRE BROKEN.

4.2 Grounding (Fig. 14 and Table 2)

Be sure to connect the ground line (labeled "G") to ground. Prior to grounding, ensure that the wire is the specified one (labeled "G").

Also, verify that grounding continuity has been established inside the motor by checking that ground wire (labeled "G") is electrically conductive with the bolt on the top of the motor (to be stripped of paint).

Ground the motor according to local codes.

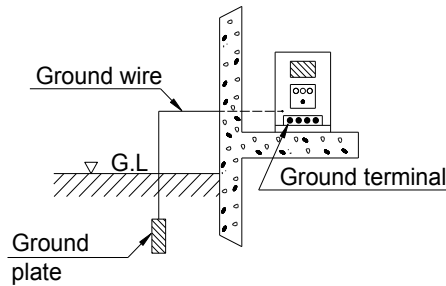

Fig. 14

Table 2 (Example)

Motor classification	Grounding resistance	Grounding line diameter
AC 600V below	10Ω	φ1.6 mm

(Source : Electrical Equipment Technical Standards, Ministry of International Trade and Industry).

4.3 Protective Device Cable Connection (Fig. 15 and Table 3)

This pump have a leakage detector at the motor bottom and a thermal protector, in the stator coil to protect the motor, with cable connections as illustrated in Fig. 15. Connect terminals P1 and P2 for the thermal detector to P1 and P2 of the same control connector. Connect the remaining terminal G to ground. Table 3 shows detailed specifications regarding protective devices.

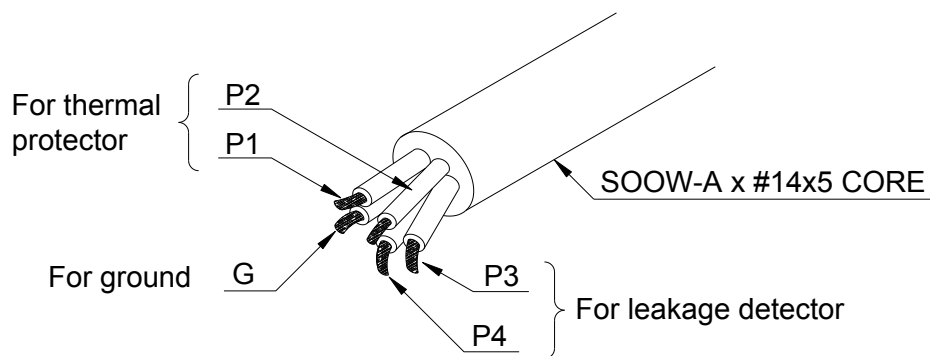

Fig. 15

Table 3

	Thermal protector	Leakage detector
Type	9700K 06-215	OLV – 5 (float type)
Manufacturer	SENSATA TECHNOLOGIES JAPAN LTD.	NOHKEN INC.
Contact rating	AC 115V/230V × 18A/12A (max)	AC 300V × 0.5A (max)
Contact type	B-contact (normally closed)	B-contact (normally closed)
Cable terminal identification	P1 P2	P3 P4
Material and size of cable	SOOW-A × #14	

⚠ WARNING : AN EARTH LEAKAGE BREAKER MUST BE USED ACCORDING TO LAW TO PREVENT ELECTRICAL ACCIDENTS.

⚠ CAUTION : A MOTOR PROTECTIVE DEVICE SHOULD BE INSTALLED ON CONTROL PANEL TO PROTECT THE SUBMERSIBLE MOTOR AGAINST OPEN-PHASE, OVER-CURRENT OR INCHING.

4.4 Water Level Switch Cable Connection (Fig. 16 and 17)

Figs. 16 and 17 illustrate typical float switch applications for water level control. Three (or four) float switches are required for single unit operation, whereas four (or five) are necessary for two-unit alternating operation. If you desire our Ebara Water Level Control Float Switch, ask us for a catalog.

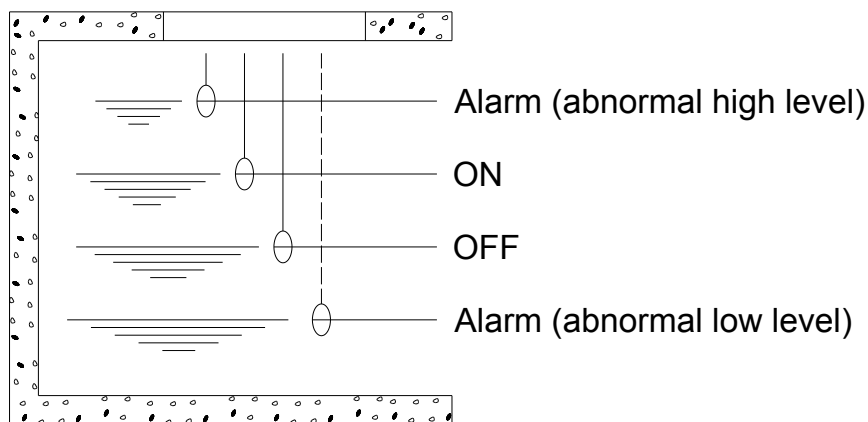

Fig. 16 Single Unit Operation

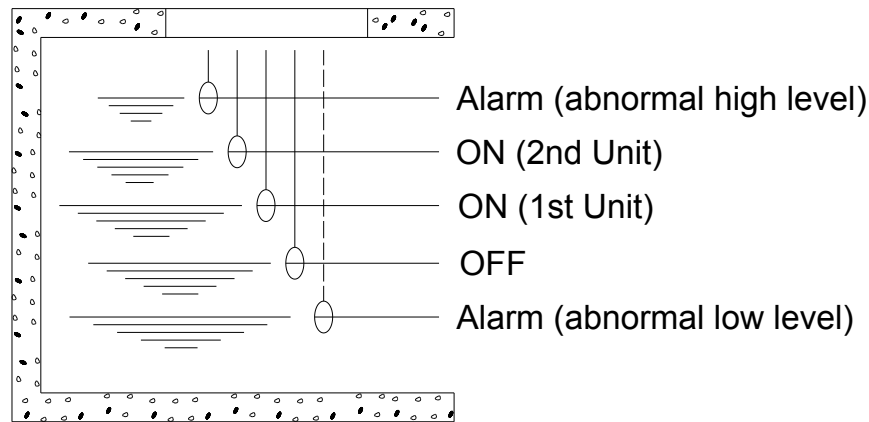

Fig. 17 Two-Unit Alternating Operation

5. Operation

5.1 Operational Limitations

This pump is designed to operate under the following conditions:

- (1) Liquid temperature : max. 40°C (104° F)
- (2) Liquid : This pump must not be used with sea water and corrosive chemicals or combustible liquids.
- (3) Lowest liquid level : Refer to lowest liquid level shown in the technical document.
- (4) Voltage variations : The motor is designed to supply its rated output at variations of up to $\pm 10\%$ of the rated voltage at the rated frequency.
- (5) Voltage balance : Balance among the supply phases should not exceed deviations in excess of $\pm 1\%$.
- (6) Frequency variations : The motor is designed do supply its rated output at variations of up to $+3\%/-5\%$ of the rated frequency at the rated voltage.
- (7) Frequency of starts : The pump should not be started in excess of 15 times per hour for 4 pole and 6 pole 50hp to 145hp, 10 times per hour for 4 pole, 6 pole and 8 pole 175hp to 245hp and 10 pole 50hp to 145hp.

5.2 Checking Rotation Direction (Figs. 18 and 19)

Check the motor for rotation direction by the following procedure after the pump has been installed in the pump pit.

A reversing pump is no problem if operation is not prolonged.

- (1) If the pump performance curve is available.

Open the sluice valve on the discharge side approximately half a turn (so that air is released and a small quantity of liquid is discharged), and turn the main switch ON. With all air released from the discharge pipe, fully close the sluice valve.

As this time, if the value of shut-off head ($H1 + H2$) (ft), where

$H1$ (ft) Compound pressure gauge reading

$H2$ (ft) Vertical distance from gauge to liquid surface

is generally in agreement with the pump performance at hand, the pump is operating normally.

If the pump is reversed, a performance curve as denoted by dashed lines in Fig. 18 is usually obtained, where the pump's discharge pressure is lower than normal or specified, and a sudden rise electric current occurs with gradual opening of sluice valve.

In this event, change connections as shown in Fig. 19.

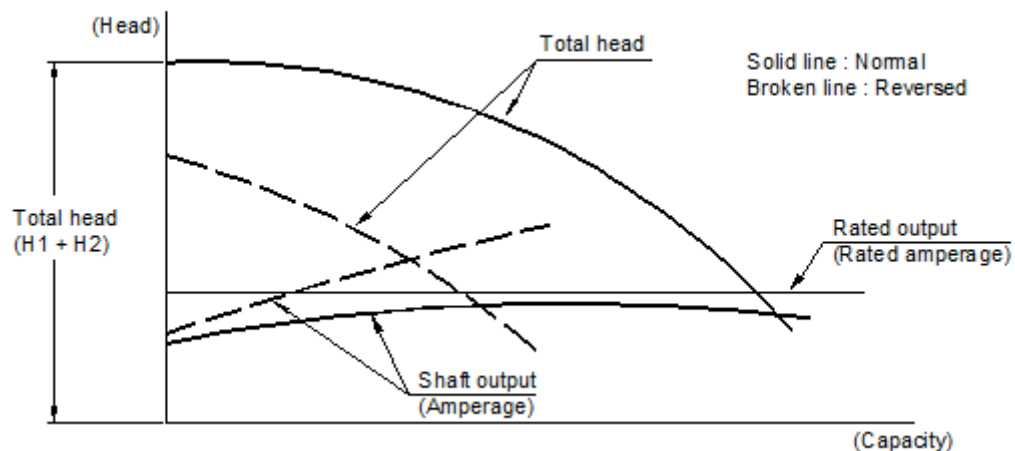

Fig. 18 Pump performance for Normal Rotation

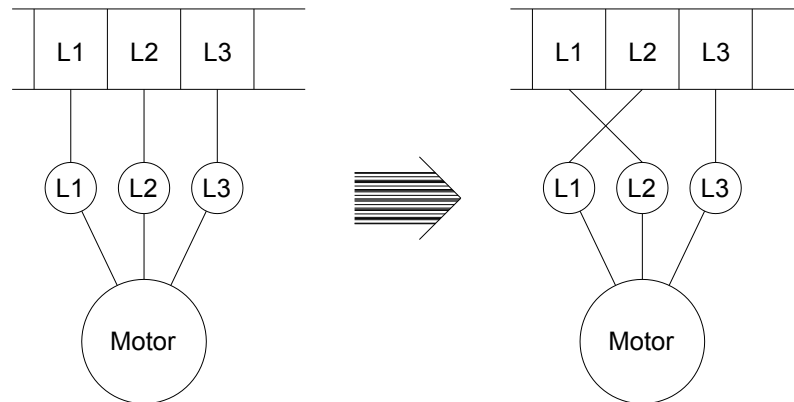

Fig. 19 Change of Connections for Normal Pump Performance

⚠ WARNING : CHECK THE PUMP TO REDUCE THE TORQUE PRODUCED BY A LARGE SIZED PUMP.

- (2) If the pressure gauge or compound pressure gauge is not installed on discharge pipe.

If checks of the rotating direction of the pump in the water as described above cannot be performed, proceed as follows.

Lay the pump on the ground. Turn switch on and off instantaneously, and check visually the rotation direction through the discharge bore of the pump. The rotating direction of the pump should be clockwise when viewed from above.

⚠ CAUTION : SINCE THE STARTING TORQUE ON LARGE PUMPS CAN BE POWERFUL, THE PUMP MUST BE SUPPORTED.

⚠ DANGER : DURING CHECKING THE DIRECTION OF ROTATION, DO NOT TOUCH ROTATING PARTS OF THE PUMP. KEEP HANDS, HAIR AND TOOLS AWAY FROM ROTATING PARTS TO PREVENT SERIOUS ACCIDENTS.

5.3 Cautions of Operation

Closed valve operation of the pump is no problem if operating is not prolonged. Otherwise, the pump not only becomes overheated but also is caused to rattle and vibrate by backward flow of the liquid at the suction port. Avoid closed valve operation as much as circumstances allow.

5.4 Operation

(1) Starting

- Open the valve if provided.

Note : A pump of lower shut off power than rated horse power may be started with the valve closed.

In such case, open the valve within 1 minute after motor start.

- Start motor

 **CAUTION** : DO NOT START THE MOTOR IF REVERSE FLOW OCCURS.

(2) Stopping

- Stop motor

Note : A pump of lower shut off power than rated horse power may be stopped just after the valve is closed.

5.5 Cautions During Operation

Pay attention to abnormal noise and vibration. If air or foreign matter enters the pump or if there is a change in the operating point, mis-operation or valve defect in the discharge lines, abnormal noise and vibration can occur. Pump discharge pressure can also vary greatly or the current meter of the motor can vary suddenly during operation.

In such cases, immediately check to find the cause of these problems.

6. Maintenance and Overhaul

While the life of the pump depends largely on the ambient conditions, daily servicing and inspection helps extend service life considerably. To achieve that, carry out the maintenance as follows :

6.1 Daily Checks

Check the following items at least once a week.

- (1) Current
If the ammeter reading exceeds the motor rating listed on the data plate or is abnormally lower than usual, it is an indication of a problem.
- (2) Voltage
Voltage should be within $\pm 10\%$ of the rated value throughout operation.
- (3) Vibration
Check for the abnormal vibrations.
- (4) Protective devices
Check protective devices by reading the panel indicator.

6.2 Monthly Checks

Check the following items at least once a month.

- (1) Discharge pressure
Check pump discharge pressure and discharge flow rate (if flow meter is provided).
- (2) Insulation resistance
Operation is safe as long as insulation resistance is more than $2M\Omega$. If higher than $2M\Omega$, but this occurs after a sharp decline from a certain value, check the cables, and / or overhaul is required.

6.3 Annual Checks

Even if there is nothing wrong with the pump under normal service condition, it should be lifted out and inspected once a year at least.

Particularly, when the pump is in use under severe conditions, such as where the liquid being handled contains sand or is corrosive, or oversized debris is pumped through, inspect it as often as circumstances allow.

A recommended procedure for inspection is outlined below. If mechanical seal must be replaced or on overhaul is considered necessary as a result of the inspection, contact nearest dealer, or us directly.

⚠ WARNING : BEFORE PULLING THE PUMP, DISCONNECT ALL CABLES AND ENSURE THAT THE PUMP IS ISOLATED FROM THE POWER SUPPLY.

⚠ WARNING : ALWAYS LIFT THE PUMP BY THE LIFTING LUGS, NEVER BY THE MOTOR CABLE.

⚠ WARNING : WHEN LIFTING THE PUMP, USE APPROPRIATE CRANE (OR HOIST) AND LIFT SYSTEM.

CHECK POSITION AND TIGHTNESS OF LIFT SYSTEM SO THAT WEIGHT OF THE PUMP IS NOT UNBALANCED.

FAILURE TO OBSERVE THIS PRECAUTION CAN RESULT IN SERIOUS ACCIDENTS.

6.3.1 Steps for Lifting Pump

- (1) Remove the floor plate. Hook the lifting chain on the hoist or motor-driven chain block.
- (2) Simply lift the whole pump body slowly as that is all that is required for lifting the pump.
It is not necessary to empty the pump pit, or remove any bolts.
- (3) If the guide pipe is deposited with dirt and the pump cannot be slip up along it smoothly, do not lifting using force but clear the pipe of dirt with a stick, etc.

6.3.2 Inspection Procedure

- (1) Appearance check
Check the impeller, cables, bolts and nuts, external surface conditions for abnormal conditions.

⚠ CAUTION : THE SEAL CHAMBER MAY BE UNDER PRESSURE. HOLD A RAG OVER THE OIL PLUG TO PREVENT SPLATTER.

- (2) Mechanical seal (upper)
 - (a) Lift the pump out of the pump pit by lifting procedure described above, and stand it on the floor in a vertical position. Unplug the “leak check” in the intermediate casing of the pump.
 - (b) If neither oil nor water leaks form the “leak check”, the mechanical seal (upper) is in satisfactory condition.

- (c) If a very small quantity of oil leaks out, there is no practical problem. If water or oil containing water, in excess of 1 liter (after one year of use), leaks out the mechanical seal must be replaced.
- (d) If much water is emitted, the mechanical seal or others components may be damaged, and an overhaul is necessary.
- (e) When inspection is completed, put a sheet gasket between the plug and the boss, and tighten the plug.

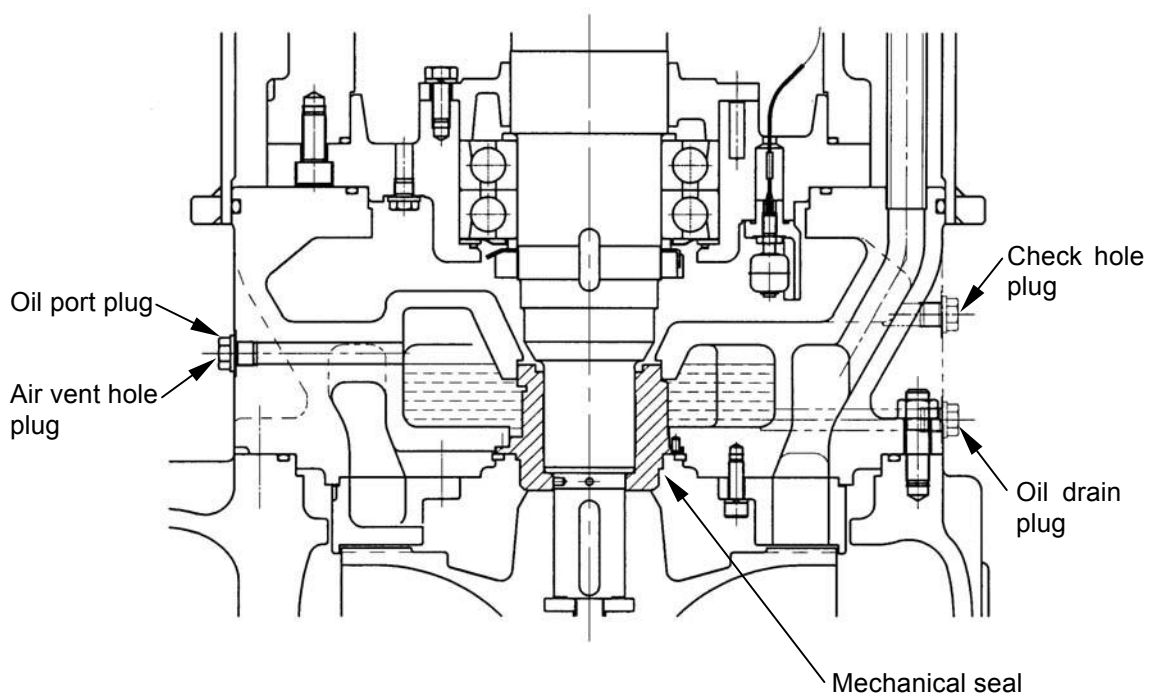

Fig. 20

(3) Mechanical Seal (lower)

- (a) Unplug the “oil drain” and “air vent” and drain all internal oil. (Refer to “Changing Oil”, Para 6.6).
- (b) If the drained oil is muddy, or milky-white, it contains water. The mechanical seal (lower) is in satisfactory condition as long as the oil does not contain much water. Otherwise, it must be replaced.
- (c) After the oil has been inspected, pour fresh oil (Turbine Oil ISO VG32) through the “oil port”, with the pump in a vertical position, till oil overflows from the “air vent”. The quantity of oil is shown in Table 1.

- (d) Replug the “oil port” as carefully as the other ports.
- (e) To replace either upper or lower mechanical seal, the pump must be disassembled. As the mechanical seal is a cartridge type, removing the retaining ring permits seal removal as a complete assembly. After the mechanical seal has been replaced with a new one, reassemble the pump and supply the specified oil through the “oil port” in the manner describe above. At this point, turn the rotating body by hand to ensure that it turns smoothly.

Also, check for oil leaks.

***ICS opt.**

(2) Mechanical seal (upper)

- (a) Lift the pump out of the pump pit by lifting procedure described above, and stand it on the floor in a vertical position. Unplug “Leak check hole” in the intermediate casing of the pump.
- (b) If no liquid leaks from “Leak check hole”, the mechanical seal (upper) is in satisfactory condition.
- (c) If a very small quantity of any liquid leaks out, there is no practical problem. If any liquid, in excess of 1 liter (after one year of use) leaks out, the mechanical seal must be replaced.
- (d) If much liquid is emitted, the mechanical seal or others components may be damaged, and an overhaul is necessary.
- (e) When inspection is completed, put a sheet gasket between the plug and the boss, and tighten the plug.

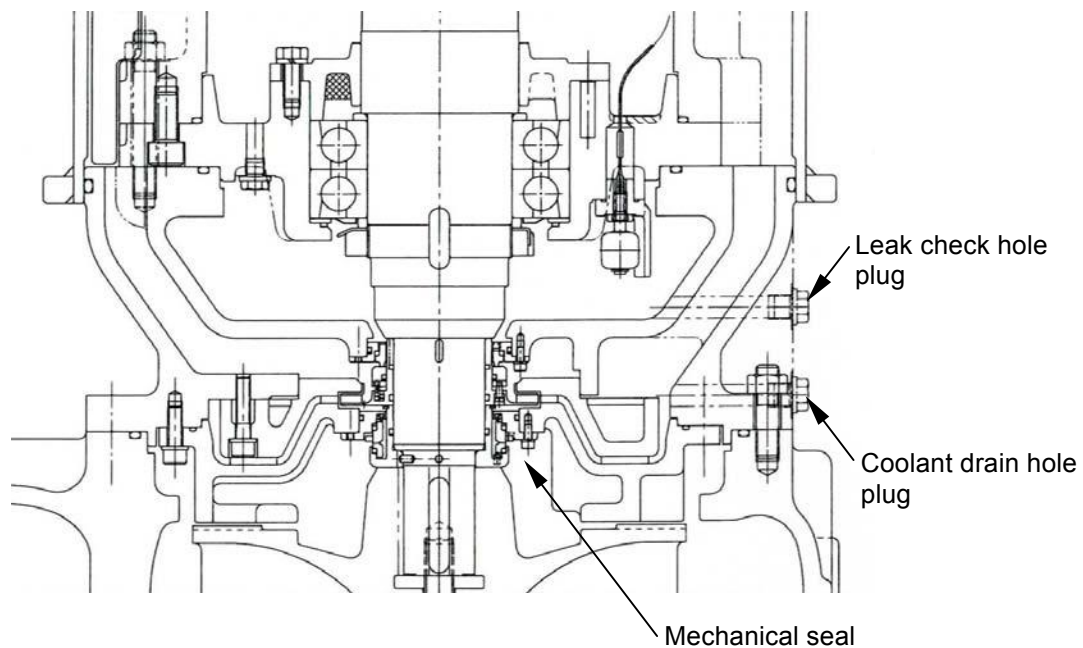

Fig. 20c

***ICS opt.** (3) Mechanical Seal (lower)

- (a) Unplug “Coolant drain hole” (shown in Fig. 20c) and “Air vent” (shown in Figs. 7c and 8c) and drain all internal coolant. (Refer to “Changing Coolant”, ***ICS opt.** Para 6.6).
- (b) If the drained coolant is muddy, or milky-white, it contains pumped liquid. The mechanical seal (lower) is in satisfactory condition as long as the coolant does not contain much pumped liquid. Otherwise, it must be replaced.
- (c) After the coolant has been inspected, pour fresh coolant (30%: Propylene glycol, 70%: Water) through the “Coolant supply hole” (shown in Figs. 7c and 8c), with the pump in a vertical position, till the coolant overflows from “Air vent & full level check hole” (shown in Figs. 7c and 8c). The quantity of coolant is shown in Table 1c.
- (d) Replug “Coolant supply hole” as carefully as the other ports.
- (e) To replace either upper or lower mechanical seal, the pump must be disassembled. After the mechanical seal has been replaced with a new one, reassemble the pump and supply the specified coolant through “Coolant supply hole” in the manner describe above. At this point, turn the rotating body by hand to ensure that it turns smoothly. Also, check for coolant leaks.

(4) Rotor

- (a) After checking the oil, put your hand through the pump discharge and turn the impeller. If it turns smoothly, the rotating components should be in satisfactory condition.
- (b) If the impeller resists or feels locked, the pump requires overhaul.

6.3.3 Reinstallation

After the pump has been thoroughly inspected, reinstall it by reversing the lifting procedure.

If dirt is caught in the elbow, lift the pump back a little and operate pump for 2 or 3 seconds to blow off the dirt.

6.4 Overhaul

Whenever the pump requires overhaul due to operational problems, poor insulation or as a result of inspection, returns it to us for the job.

Pumps should be overhauled for general inspection every second year to prevent major troubles even if there are no apparent problems.

(1) Cable disposition

When the pump is lifted for overhaul, it is necessary to disconnect all cables from the control panel terminal board. At this time, if the cables are pulled out from the floor-level elbow, reinstallation becomes difficult.

To prevent this, pull the cables with their ends tied with string. When the cables are put back into their original position after overhaul, tie the cables ends again with the same string and pull from the opposite side.

(2) Details of overhaul

Overhaul consists of the following work (to be done at our shop) :

- (a) Complete disassembly, inspection and cleaning of pump.
- (b) Inspection of starter coil and insulation test.
- (c) Replacement of worn and damage parts.
- (d) Functional tests.
- (e) Performance tests. (If required)

6.5 Disassembly and Reassembly

⚠ WARNING : WHEN DISASSEMBLING THE PUMP, WARNING SIGNS MUST BE POSTED NEARBY TO PREVENT MISOPERATION BY THIRD PARTIES. FAILURE TO OBSERVE THIS PRECAUTION CAN RESULT IN DAMAGE OR SERIOUS ACCIDENTS.

⚠ WARNING : DURING PUMP DISASSEMBLY AND REASSEMBLY, ENSURE THAT THE CABLES ARE DISCONNECTED AND ISOLATED FROM THE POWER SUPPLY.

6.5.1 Preparation for Disassembly and Reassembly

An adequate workspace should be found which is as wide as possible, and has a rigid floor. The area should be safe from hazards. The following should be prepared before disassembly and reassembly.

- Lifting devices.
- Wooden supports and pads.
- Standard tools.
- Special tools.
- Teflon tape or liquid packing.
- Rags.

⚠ WARNING : DURING DISASSEMBLY AND REASSEMBLY, BE SURE TO USE APPROPRIATE CRANE (OR HOIST) AND WIRE ROPES. USE OF IMPROPER CRANE AND WIRE ROPES CAN RESULT IN SERIOUS ACCIDENTS. FAILURE TO OBSERVE THIS PRECAUTION CAN RESULT IN SERIOUS ACCIDENTS.

6.5.2 Cautions for Disassembly

- (1) Cautions for unloading products
 - (a) When hoisting heavy loads such as the pump proper, pay careful attention to attaching the sling so that the load will be centered and the sling does not slip.
 - (b) When lifting heavy parts, use soft padding under the wire to protect the coated and machined surfaces. Do not raise or lower the parts too rapidly with the crane.
 - (c) When assembling components on the floor, use protective blocks under the components to protect the coated surfaces and prevent rolling.

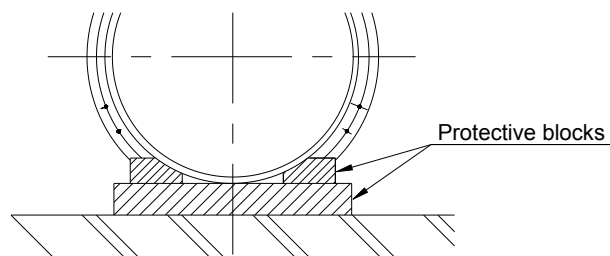

Fig. 21

- (2) Protect surfaces of mating flanges and the corners of spigot and socket.
- (3) Cover the shaft threads to protect from damage after disassembly.
- (4) After disassembly, apply temporary rust prevention to the machined surfaces such as lifted surfaces, threads, shafts, etc.
- (5) Be careful not to drop tools and parts into the sump pit.
- (6) To protect against lost parts and mixing of parts with those from another machine, provide cases for disassembled parts and store parts in cases.
- (7) Store bolts in bags as a set.
- (8) Do not disassembly the motor. If the motor requires disassembly, please contact us.

6.6 Replacing Components

(1) Changing oil

Stand the pump in a vertical position, and unplug “oil drain” and “air vent”. Drain all oil from the “oil drain” (In case of model “F”, “G”, “D1”, “D2”, “G1” and “G2” using the oil pump.)

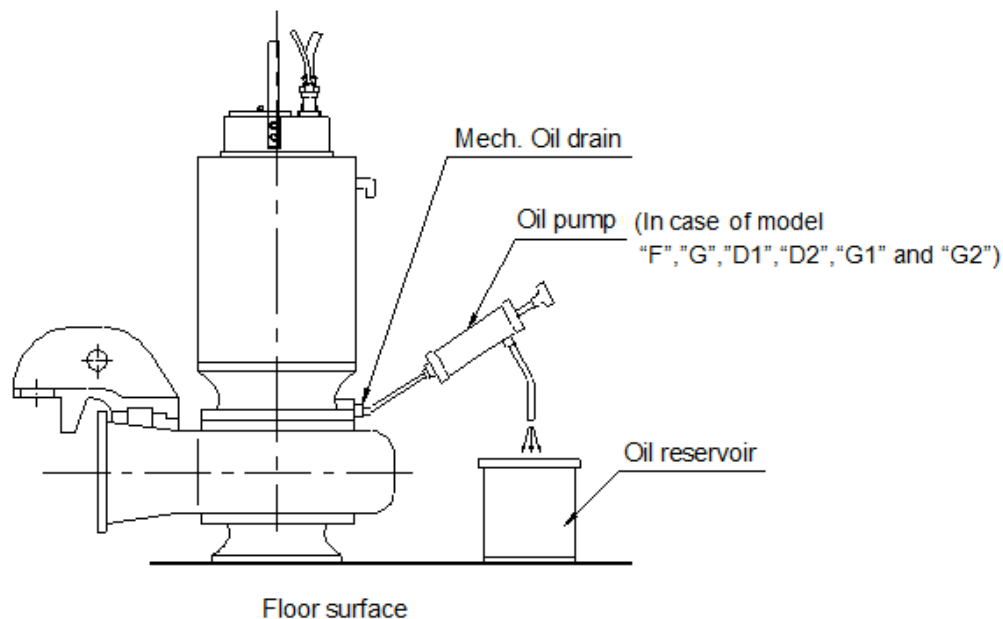

Fig. 22

Inspect the oil for water contamination. If the oil contains much water, mechanical seal must be replaced.

After the oil has been inspected, pour oil (Turbine Oil ISO VG 32) through the “oil port”, until oil overflows from “air vent”.

Put a sheet gasket between the plug and the boss, and tighten the plug.
(Refer to Para. 3.6.1)

ICS opt.*6.6 Replacing Components**

(1) Changing coolant

Stand the pump in a vertical position, and unplug “Coolant drain hole” (shown in Fig. 20c) and “Air vent & full level check hole” (shown in Figs. 7c and 8c). Drain all the coolant from “Coolant drain hole”.

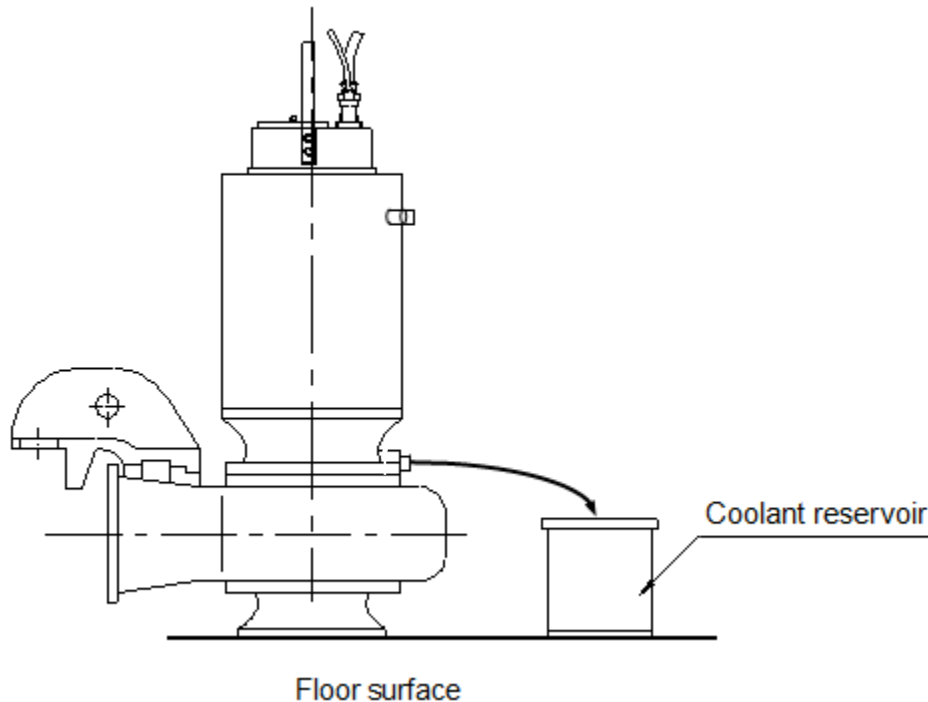

Fig. 22c

Inspect the coolant for contamination. If the coolant contains much pumped liquid, the mechanical seal must be replaced.

After the coolant has been inspected, pour coolant (30%: Propylene glycol, 70%: Water) through “Coolant supply hole”, until the coolant overflows from “Air vent & full level check hole”, and tighten the plugs. (Refer to ***ICS opt.** Para. 3.6.1)

- (2) Impeller disassembly
 Remove the impeller bolt cap and impeller bolt with special tools.
 Remove the impeller with special pull out tool. (Refer to Fig. 23)

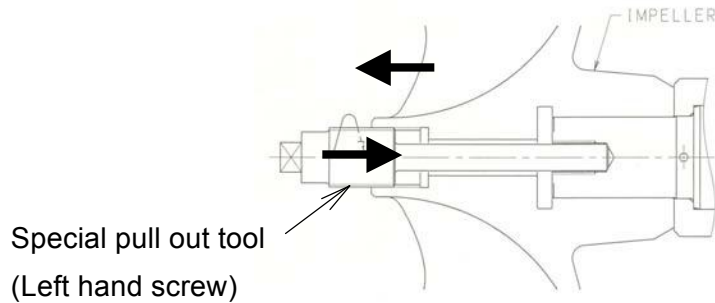

Fig. 23

- (3) Mechanical seal replacement (Refer to Fig. 24)
 (a) Remove the snap ring (A) from intermediate casing.
 (b) Remove the mechanical seal by using push bolts (B).

For assembly, reverse the above steps.

After installing the mechanical seal, fill the threads (C) with the silicon-rubber sealant (SHIN-ETSU CHEMICAL Co., Ltd. KE-45 or equivalent).

⚠ CAUTION : DO NOT COMPLETELY DISASSEMBLE THE MECHANICAL SEAL.

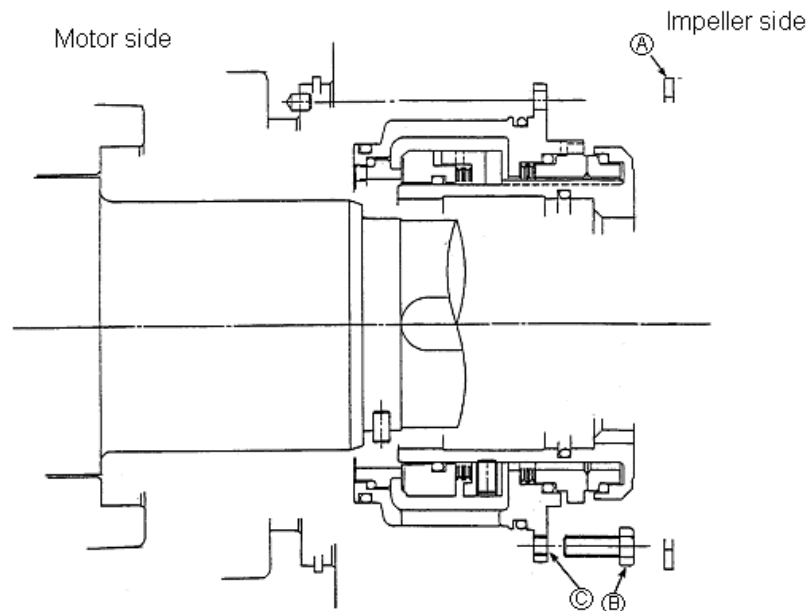

Fig. 24

***ICS opt.**

(3) Mechanical seal replacement (Refer to Fig. 24c)

When removing "1. Lower stationary side & rotating side assy" or "5. Upper stationary side assy", use two push bolts (M5).

(There are two female threads (M5) on the flange part of each assy.)

For assembly, reverse the above steps.

After installing the mechanical seal, fill the above female threads (for push bolts) with the silicon-rubber sealant (SHIN-ETSU CHEMICAL Co., Ltd. KE-45 or equivalent).

⚠ CAUTION : DO NOT COMPLETELY DISASSEMBLE THE MECHANICAL SEAL.

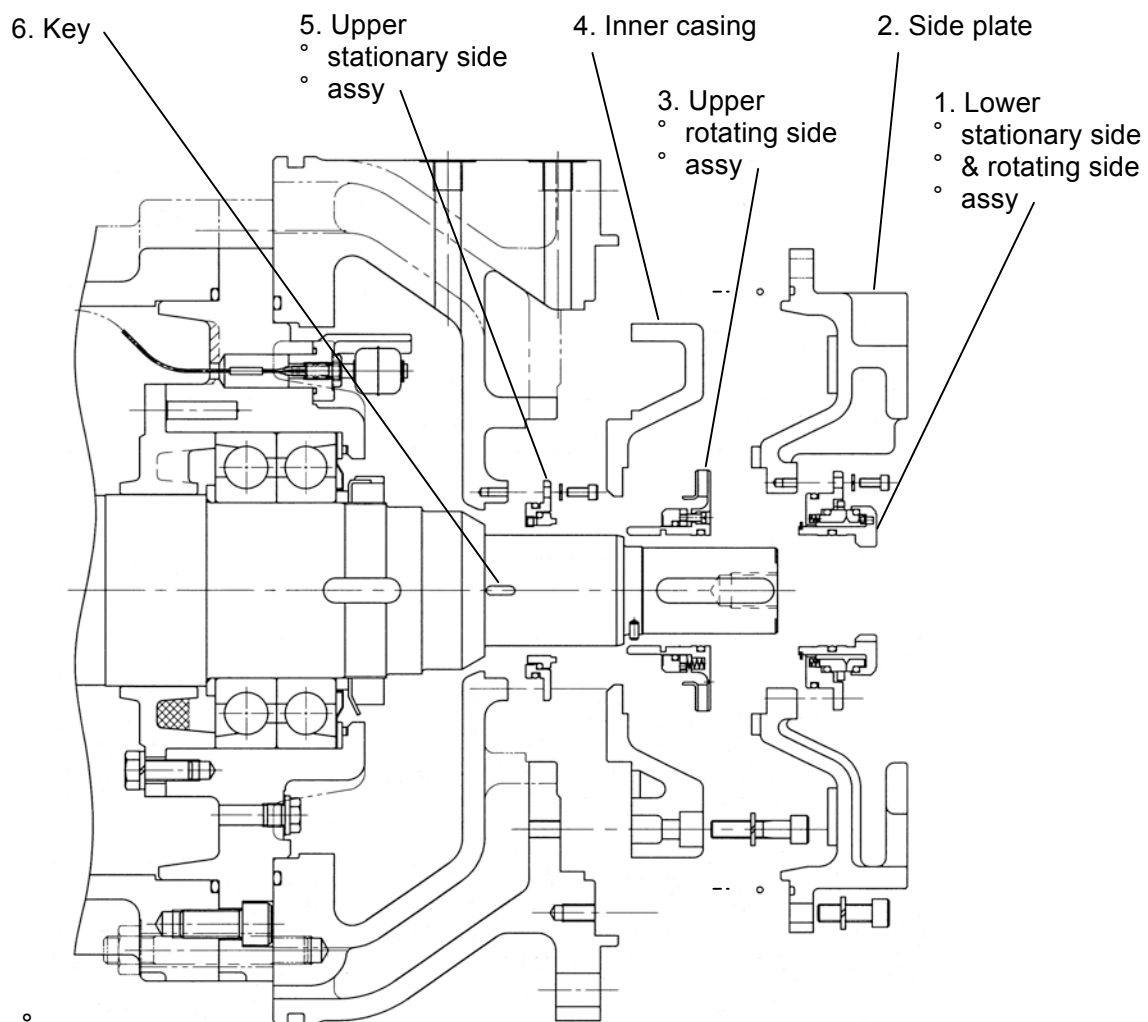

Fig. 24c

The disposition of the casings seen from the opposite side of the motor is as follows. The standard direction should be matched with the discharge direction.

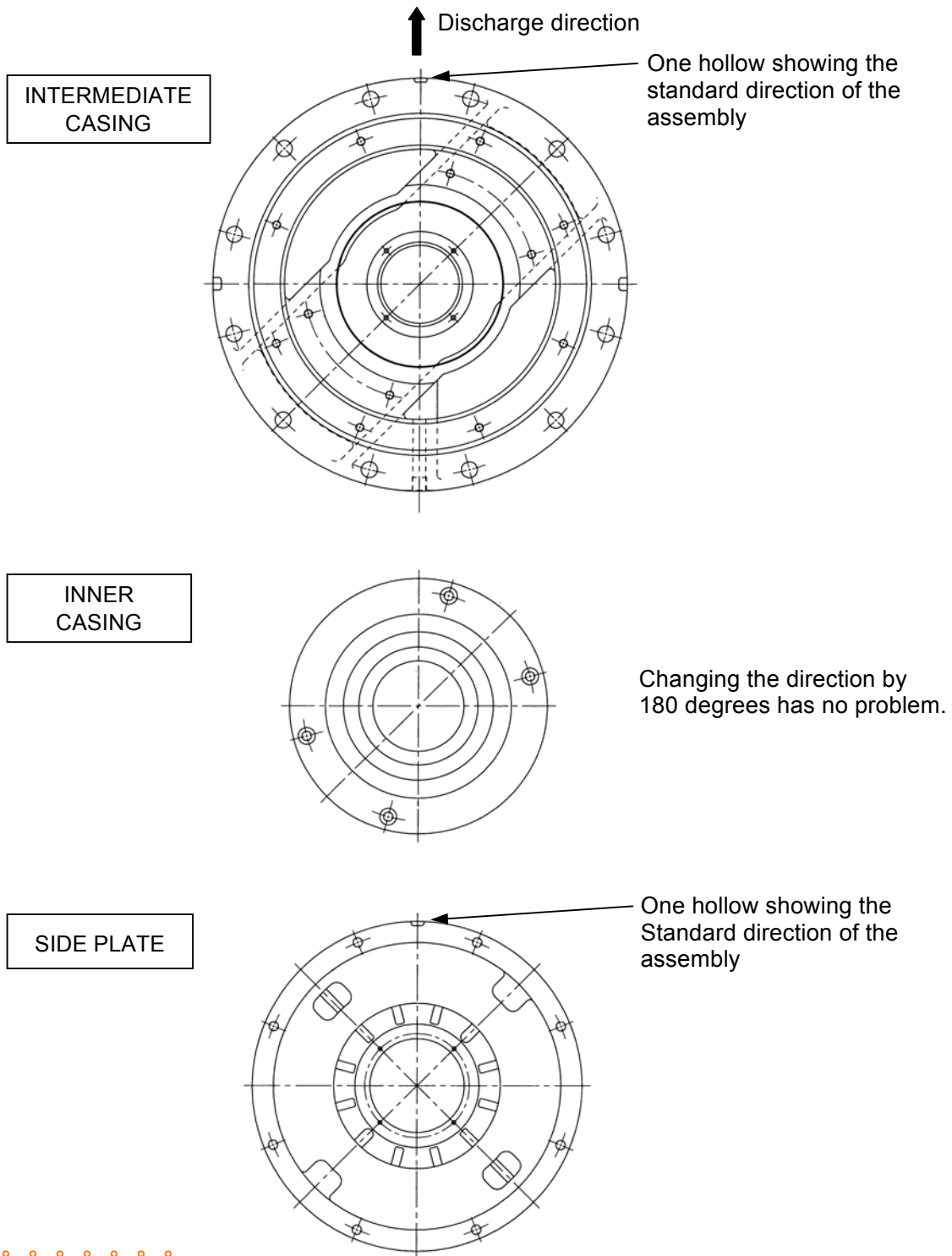

Fig. 25c

The situation after the completion of the assembly of the mechanical seal is as follows.

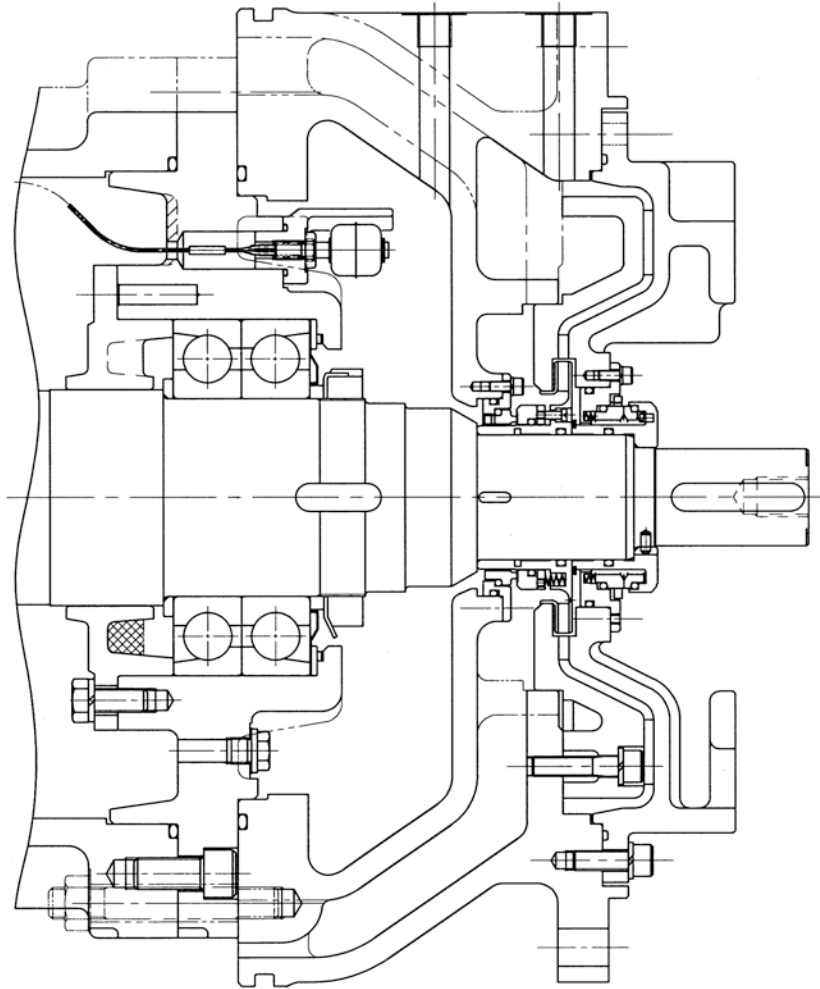

Fig. 26c

(4) Torque table

Table 4

Bolt Size	Torque kg.m (Ft.lbs.)	
	Without anti seized compound	With anti seized compound
M8	1.1 (8)	0.8 (6)
M10	2.2 (16)	1.5 (11)
M12	3.8 (28)	2.6 (18)
M16	9.1 (66)	6.2 (45)
M20	17.8 (129)	12.1 (88)
M22	24.0 (174)	16.2 (117)
M24	30.8 (223)	20.9 (151)
M30	61.4 (444)	41.6 (301)
M36	107.0 (774)	72.4 (524)

⚠ WARNING : WHEN MACHINES SURFACES ARE DAMAGED AND MUST BE REPAIRED, USE AN APPROPRIATE GRINDER. DURING GRINDING WORK, APPROVED PROTECTIVE GOGGLES MUST ALSO BE WORN.

7. Troubleshooting

Symptoms	Probable Causes	Remedies
Pump fails to start	<ul style="list-style-type: none"> ○ Defective cable or motor. ○ Malfunction inside control panel. ○ Power source trouble. ○ Pump is mechanically locked. ○ Defective protector. 	<ul style="list-style-type: none"> ○ Lifts pump and replace cable or motor. ○ Inspection made by competent electrician. ○ Inspection made by competent electrician. ○ Lift pump, inspect and/or overhaul. ○ Replace protector.
Pump fails to function despite motor operation	<ul style="list-style-type: none"> ○ System head too high. ○ Clogged discharge pipe (Pressure too high). ○ Clogged pump or strainer (Pressure too low). ○ Wrong direction rotation. ○ Internal pump wear. ○ Valve is closed. 	<ul style="list-style-type: none"> ○ Recheck requirements. ○ Clean discharge pipe. ○ Clean strainer or impeller and casing. ○ Check and change rotation. Transpose two of three phase leads at panel. ○ Repair and/or replace. ○ Check valve operation.
Insufficient capacity	<ul style="list-style-type: none"> ○ Air suction. ○ System head too high. ○ Clogged discharge pipe. (Pressure too high) ○ Clogged pump or strainer. (Pressure too low) ○ Air accumulation in pipe. ○ Internal pump wear. ○ Wrong direction rotation. ○ Liquid viscosity different from design value. ○ Damaged impeller. 	<ul style="list-style-type: none"> ○ Raise water level in pump pit. ○ Recheck requirements. ○ Clean discharge pipe. ○ Clean strainer, impeller and bowl. ○ Install air vent valve. ○ Repair and/or replace. ○ Check and change rotation. Transpose two of the three phase leads at panel. ○ Recheck requirements. ○ Repair and/or replace
Excessive current	<ul style="list-style-type: none"> ○ Gravity of pumped liquid greater than that specified. ○ Sand mixed with water. ○ Refer to "Pump fails to start" 	<ul style="list-style-type: none"> ○ Change pump unit. ○ Lift the pump and overhaul. Remove sand in tank.
Vibration and/or noise	<ul style="list-style-type: none"> ○ Internal pump wear. ○ Clogged pump. ○ Cavitation or vortex. ○ Resonance in pipe line or foundation. ○ Rotating component in contact with fixed component. ○ Damaged impeller. 	<ul style="list-style-type: none"> ○ Repair and/or replace. ○ Clean pump. ○ Raise suction water level. Operate at proper flow rate. ○ Repair to change characteristic vibration. ○ Internal pump check. Repair and/or replace. ○ Repair and/or replace.



*Contact your dealer or supplier
for more information about other EBARA products:*



EBARA Fluid Handling

1651 Cedar Line Drive • Rock Hill, SC 29730

(803) 327-5005 (t) • (803) 327-5097 (f)

www.pumpsebara.com

© 2015 EBARA International Corporation

EICDSC4x 0415