

EBARA



# Submersible Axial Flow Propeller Pumps

Model DSZ3



water | wastewater | flood control



**EBARA**

**EBARA** Fluid Handling

*an EBARA International Corporation company*

# Model DSZ3

## Features

- **Watertight cable entry system** prevents capillary action and protects against moisture; reduces maintenance costs
- **Junction area** includes a terminal board for cable connections allowing for fast efficient replacement; area sealed from the stator housing; prevents leakage into the motor; reduces the possibility of failure
- **Heavy duty, high efficiency, air filled motor, Class F** insulated, rated for 311°F with a 1.10 service factor dissipates heat easily; thermal protection in each phase of windings protects; operates cooler with higher efficiencies; longer service life with lower operating costs
- **Double and triple row grease bearings** carries thrust loading with L-10 life of 100,000 hours; ensures long, dependable operation and lowers maintenance costs
- **Float type leakage detector** provides early warning of mechanical seal failure; avoids costly motor repairs
- **Cartridge type, duplex mechanical seals** assembled in tandem arrangement; easy maintenance and high reliability
- **High efficiency, axial flow impellers** accept large diameter solids; lowers operating costs
- **Replaceable case liner** maintains working clearances while lowering case replacement costs

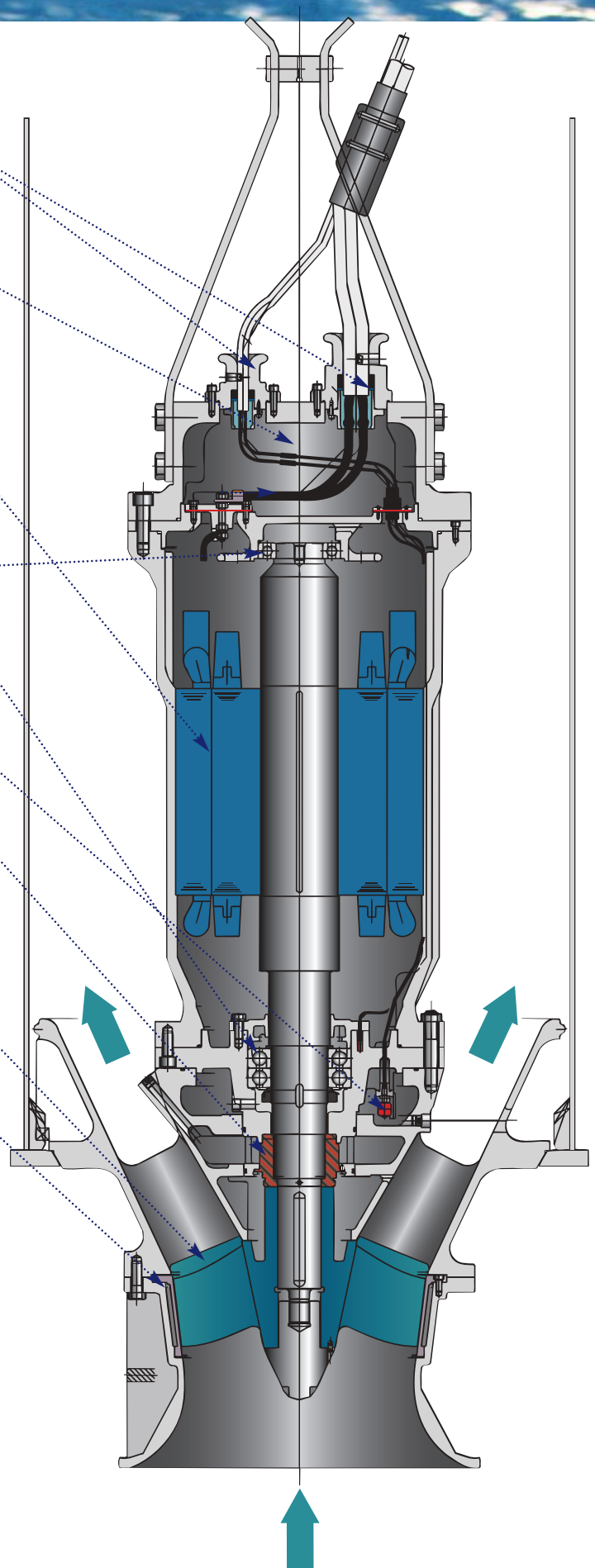

## Sealed junction area

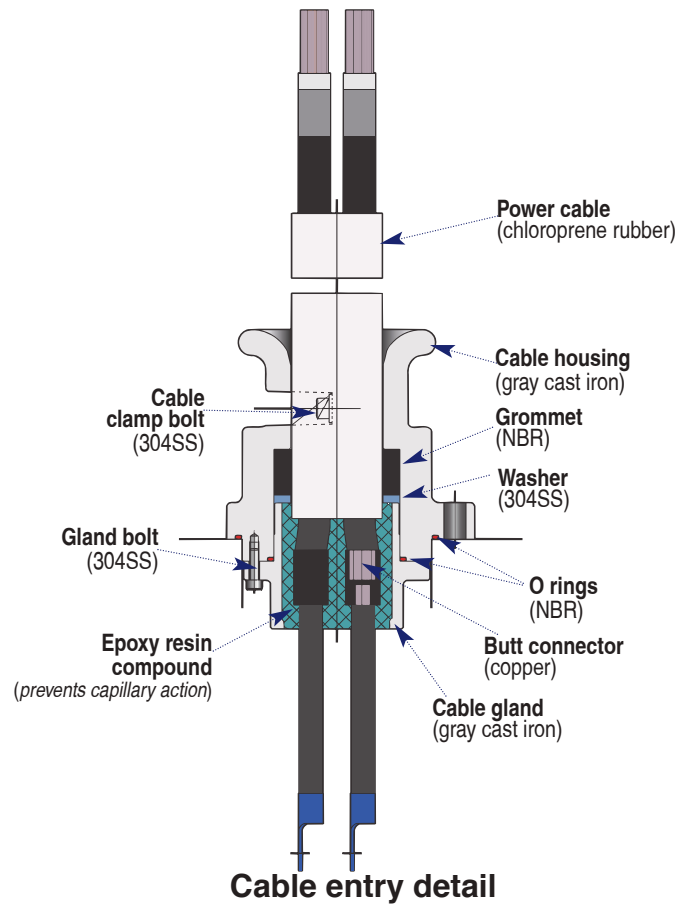
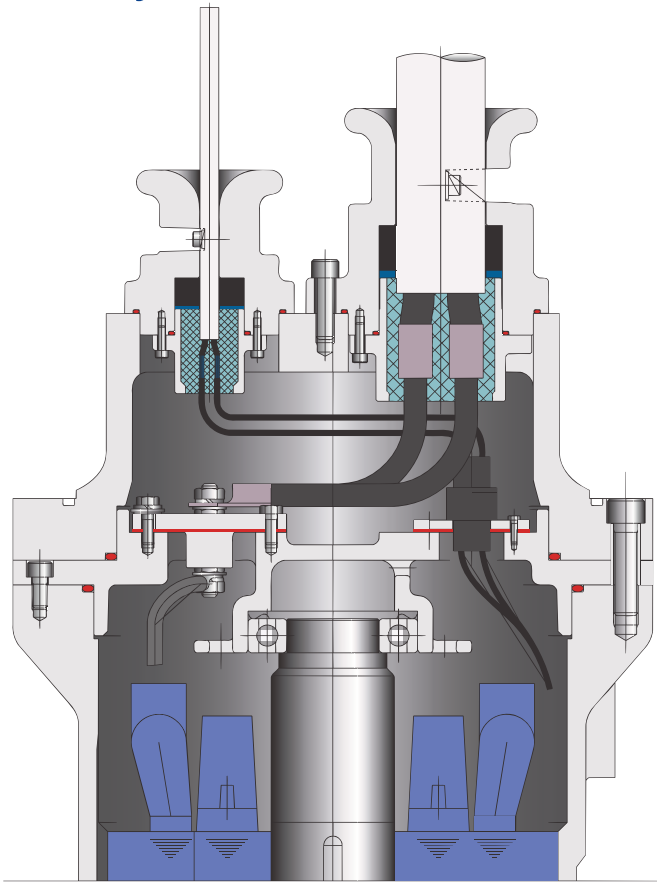

## Leak detection area

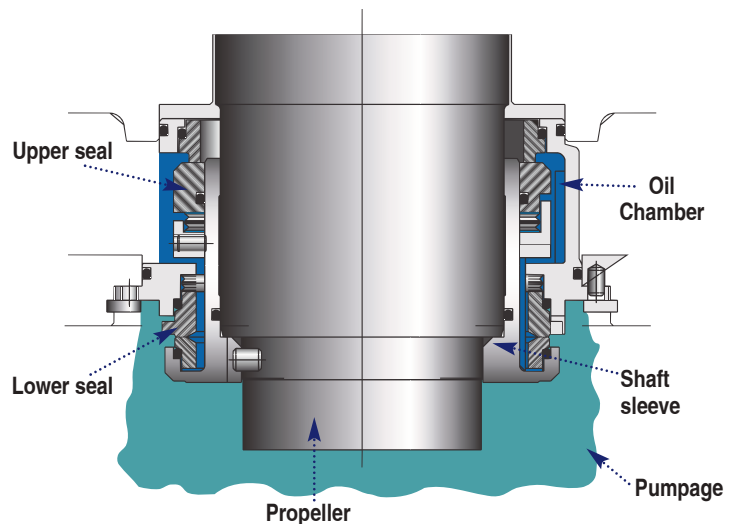
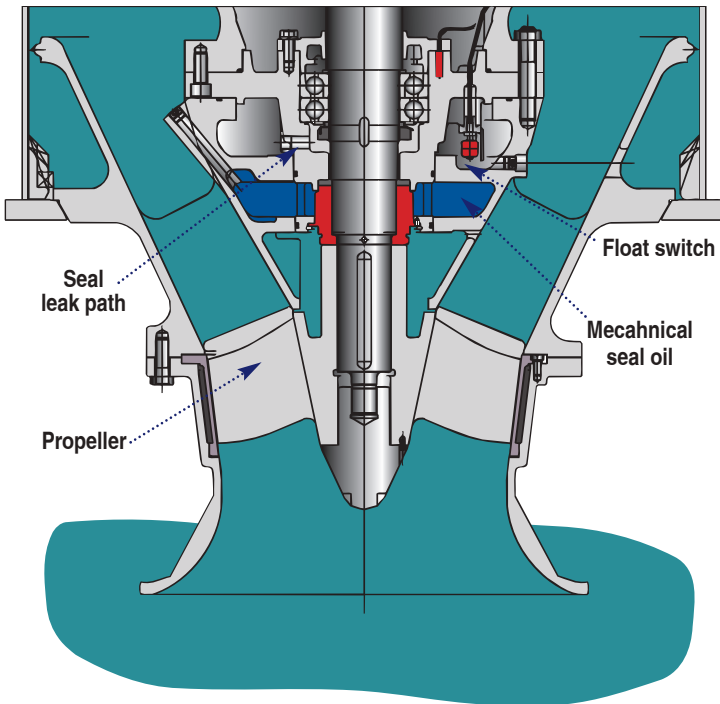

- Upper seal O rings — NBR
- Upper seal faces — Carbon vs Ceramic
- Lower seal O rings — Viton
- Lower seal faces — Silicon carbide vs Silicon carbide
- Seal springs — 304SS
- Shaft sleeve — 304SS

*Note:* Optional seal face materials available

## Double mechanical seal detail

# Materials

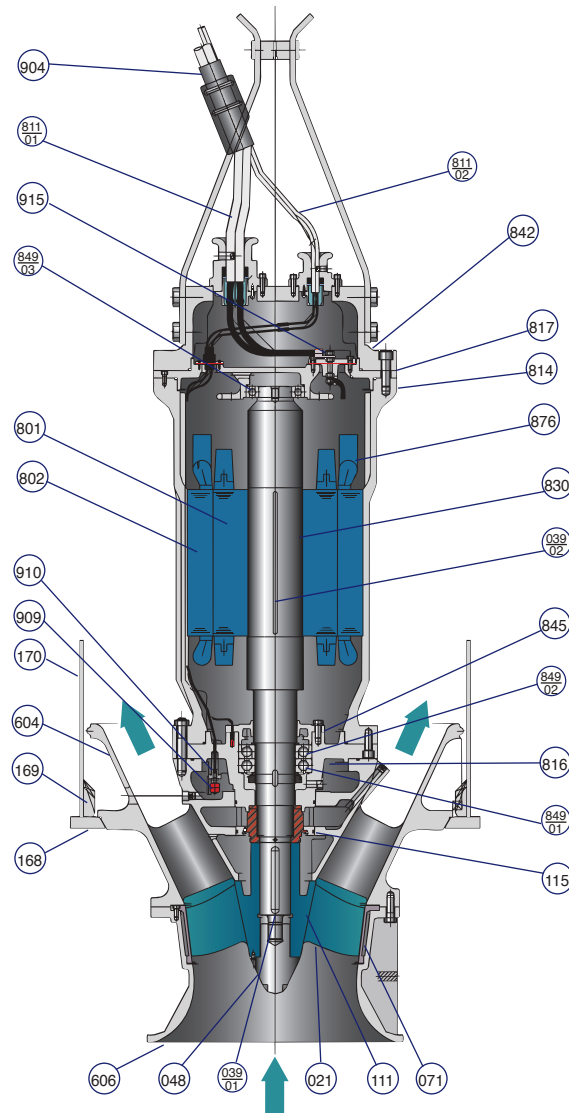

No.	Qty	Part Name	Material	ATM/AISI Code	No.	Qty	Part Name	Material	ATM/AISI Code
915	1	Terminal Board			811-01	1	Power Cable		
910	1	Leakage Detector Support	Cast Iron	ASTM A48 CL. 30	802	1	Stator	Copper	
909	1	Leakage Detector			801	1	Rotor	Aluminum	
904	1	Lifting Hanger	Steel	ASTM A283 GR.D	606	1	Suction Bell	Cast Iron	ASTM A48 CL. 35
876	1	Thermal Protector			604	1	Discharge Bowl	Cast Iron	ASTM A48 CL. 35
849-03	1	Ball Bearing	Steel		170	1	Column Pipe	Steel	ASTM A283 GR. D
849-02	1	Ball Bearing	Steel		169	1	Rotation Stopper	Steel	ASTM A283 GR. D
849-01	1	Ball Bearing	Steel		168	1	Sole Plate	Steel	ASTM A283 GR. D
845	1	Bearing Cover	Cast Iron	ASTM A48 CL. 30	115	1	O-Ring	NBR	
842	1	Motor Cover	Cast Iron	ASTM A48 CL. 35	111	1	Mechanical Seal	See Detail	
830	1	Shaft	Stainless	AISI 403	071	1	Casing Liner	Stainless	ASTM A743-CF8
817	1	Opposite Side Bracket	Cast Iron	ASTM A48 CL. 35	048	1	Impeller Nut	Stainless	AISI 403
816	1	Power Side Bracket	Cast Iron	ASTM A48 CL. 35	039-02	1	Key	Steel	AISI 1050
814	1	Motor Frame	Cast Iron	ASTM A48 CL. 35	039-01	1	Key	Stainless	AISI 420
811-02	1	Control Cable			021	1	Impeller	Ductile Iron	ASTM A536-60-40

## Optional Materials

021	1	Impeller
021	1	Impeller

Stainless	ASTM A743 CF8
Bronze	ASTM B584 C90300

## Notes

- Mechanical Seal Shaft Sleeve is Stainless Steel.
- Other materials available, consult EBARA.

# Model DSZ3

## Specifications

- Capacities to 55,000 GPM
- Heads to 55 feet
- Horsepower range to 800 HP
- RPM range 600 to 1,800
- Liquid temperatures to 104 F
- Submergence to 114 feet (35 m)
- Stainless steel shaft
- Replaceable case liner
- Cartridge mechanical seal assembly
- 1.10 Motor service factor
- 10 starts per hour
- Bearing L-10 life of 100,000 hours
- Optional five year warranty
- Seal leak detection system
- Motor winding protection
- Thrust bearing protection
- FM explosion proof models available

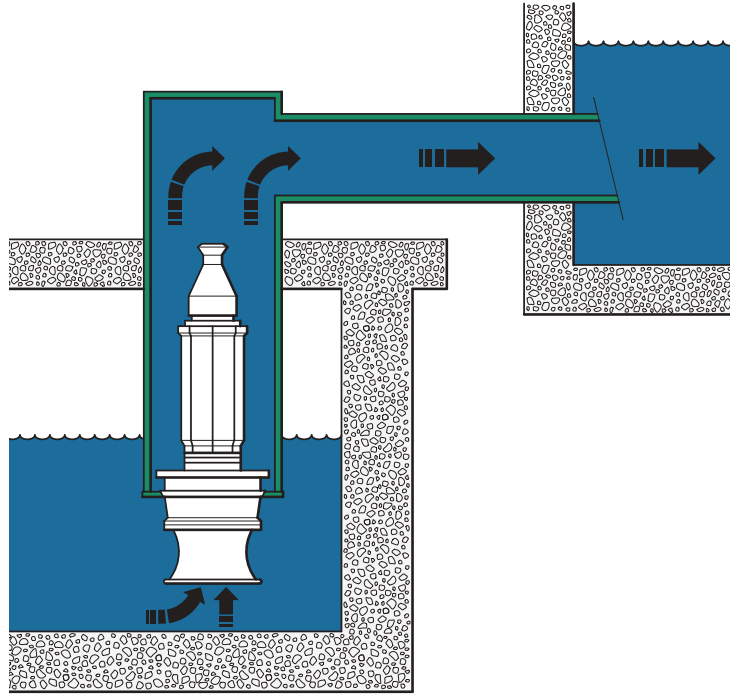

Vertical suspended column with horizontal discharge

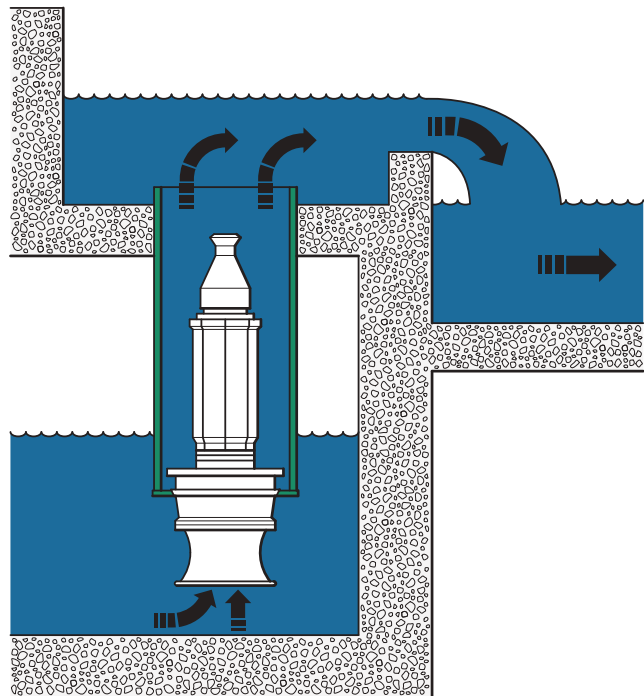

Vertical suspended column with vertical discharge

# Model DSZ3

## Selection Chart

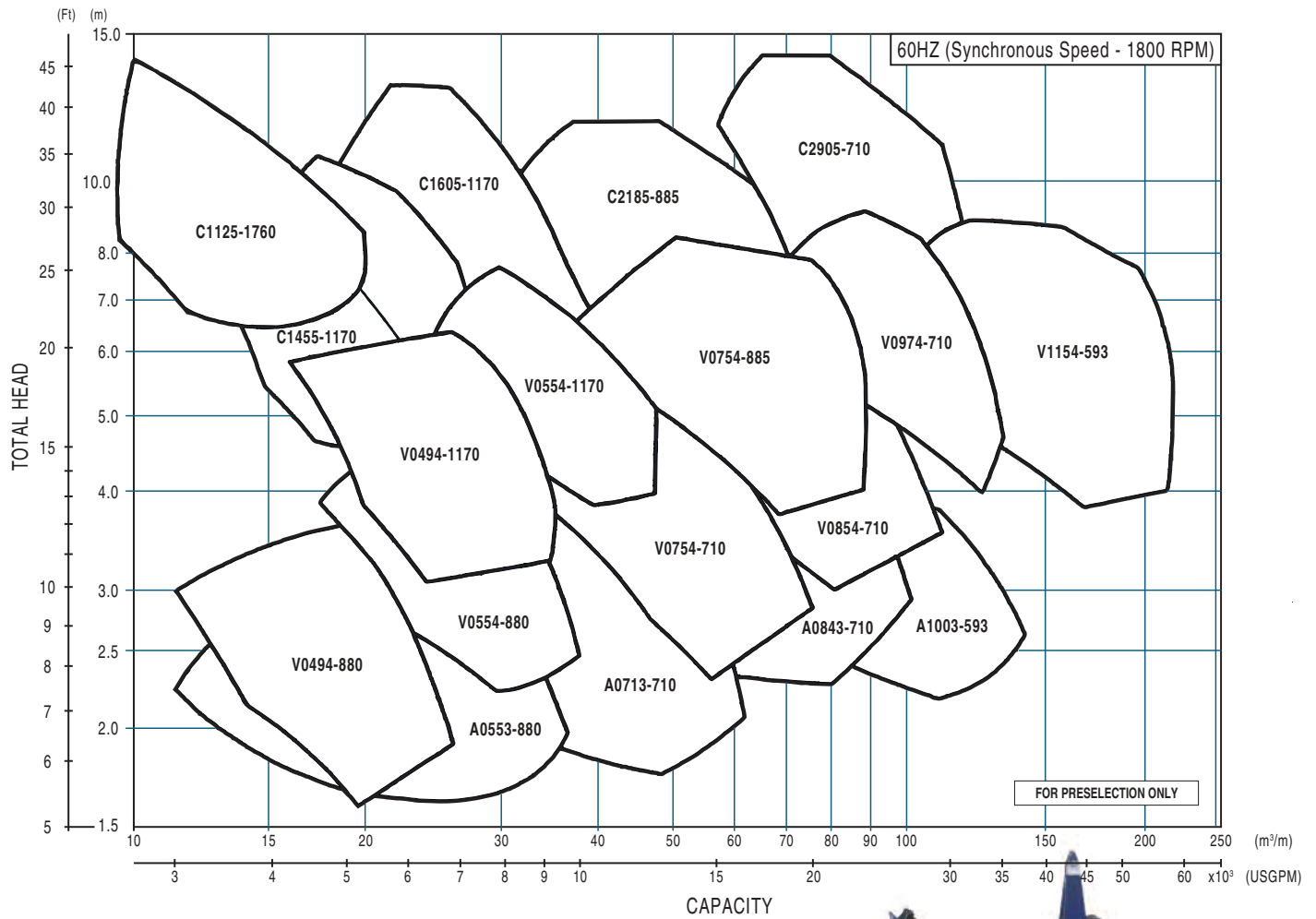

### EBARA Fluid Handling

1651 Cedar Line Drive • Rock Hill, SC 29730 • t (803) 327-5005 • f (803) 327-5097

[www.pumpsebara.com](http://www.pumpsebara.com)

© 2011 EBARA International Corporation, All rights reserved.

EFHDSZ0116