

**Contents**

**Model DVFU**

|            |             |             |             |
|------------|-------------|-------------|-------------|
| 50DVFU61.5 | 80DVFU61.5  | 100DVFU63.7 | 150DVBFU611 |
| 50DVFU62.2 | 80DVBFU62.2 | 100DVFU65.5 | 150DVBFU615 |
|            | 80DVCFU62.2 | 100DVFU67.5 | 150DVBFU618 |
|            | 80DVBFU63.7 | 100DVBFU611 | 150DVCFU618 |
|            | 80DVCFU63.7 | 100DVCFU611 | 150DVBFU622 |
|            | 80DVFU65.5  | 100DVDFU611 | 150DVCFU622 |
|            | 80DVFU67.5  | 100DVCFU615 |             |
|            | 80DVBFU611  | 100DVDFU615 |             |
|            | 80DVCFU611  | 100DVDFU618 |             |
|            | 80DVCFU615  | 100DVDFU622 |             |
|            | 80DVCFU618  |             |             |
|            | 80DVCFU622  |             |             |

| Section                         | Page    |
|---------------------------------|---------|
| Specifications                  | 2-217   |
| Selection Chart                 | 2-217   |
| Performance Curves              | 2-222   |
| Outline Drawings                | 2-232   |
| Sectional View                  | 2-245   |
| QDC Information                 | 2-278   |
| Technical Information           | 2-289.1 |
| material specification          |         |
| impeller description            |         |
| motor protection                |         |
| cable entry                     |         |
| paint specifications            |         |
| mechanical seal                 |         |
| general                         |         |
| Motor Data                      | 2-315.1 |
| motor electrical specifications |         |
| cable data                      |         |
| wiring diagrams                 |         |
| motor electrical data           |         |

**Model Designation**

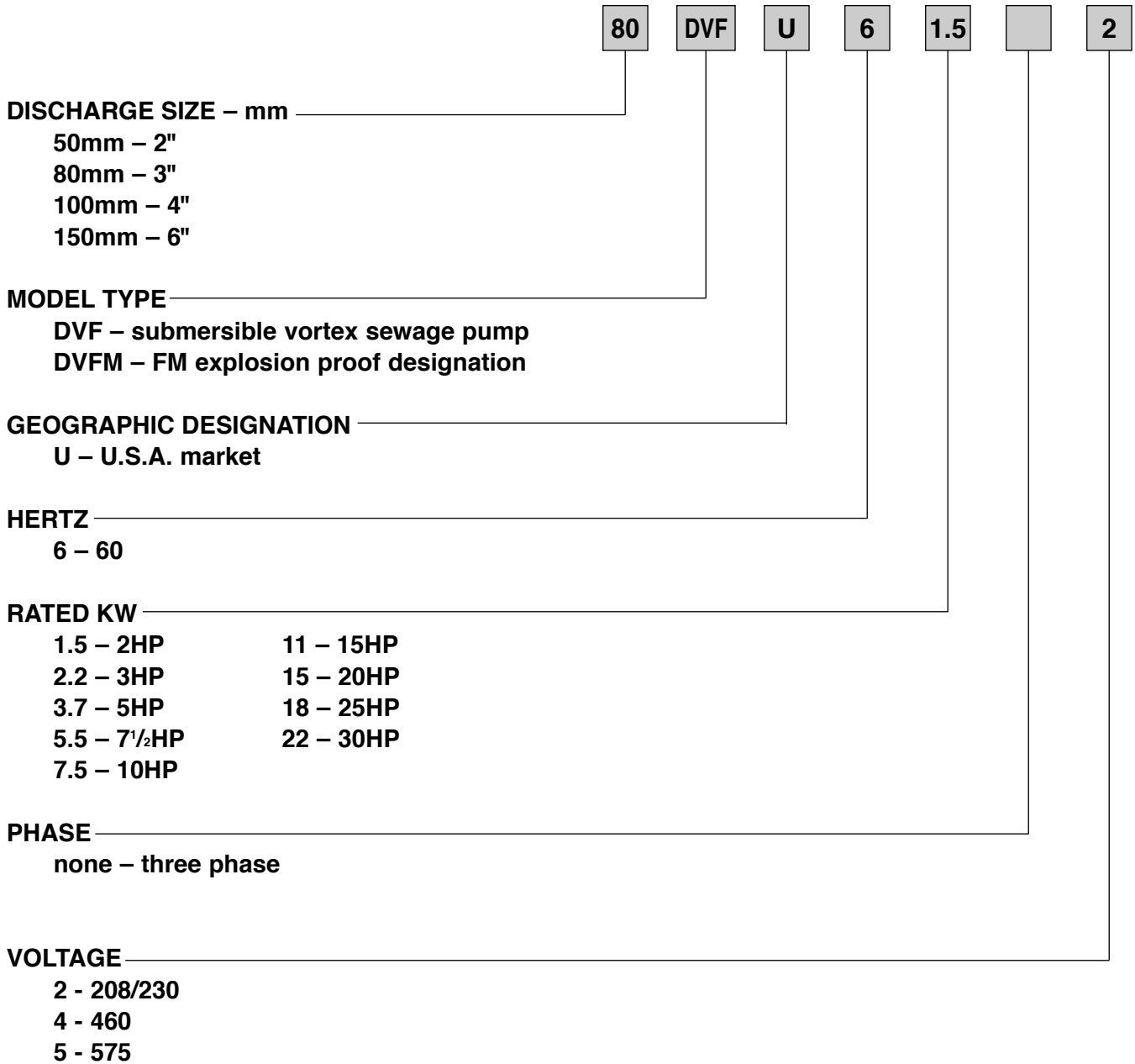

**Specifications**

|  | <b>Standard</b>  | <b>Optional</b>  |
|--|--|--|
| Size   | 2, 3, 4, 6 inch  |  |
| Range of HP<br>Range of Performance  | 2 to 30 HP<br>Capacity 16 to 1200 GPM<br>Head 13 to 121 feet   |  |
| <b>Limitation</b><br>Maximum Water Temperature   | 104°F (40°C)   |  |
| <b>Synchronous Speed</b>   | 1800 RPM   |  |
| <b>Materials</b><br>Casing<br>Impeller<br>Shaft<br><br>Motor Frame<br>Fastener   | Cast Iron<br>Cast Iron<br>403 Stainless Steel for 2 to 5HP<br>420 Stainless Steel for 7½ to 30HP<br>Cast Iron<br>304 Stainless Steel   |  |
| <b>Mechanical Seal</b><br>Material   Upper Side<br>Material   Lower Side<br>Impeller Type<br>Bearing<br>Motor<br>Three Phase<br>Motor Protection | Double Mechanical Seal<br>Carbon/Ceramic<br>Silicon Carbide/Silicon Carbide<br>Semi-open Recessed Vortex<br>Prelubricated Ball Bearing<br>Insulation Class H<br>208/230V, 460V<br>Built-in Thermal Detector   Klixons<br>Built-in Leakage Detector | FM Explosion Proof, Class 1,<br>Division 1, Group C, D |
| Submersible cable  | 33 ft. (2 to 5 HP)<br>40 ft. (7½ to 30 HP)   | ____ ft. (customer specified)                          |
| Accessories  |  | QDC System   |



Selection chart

Three Phase

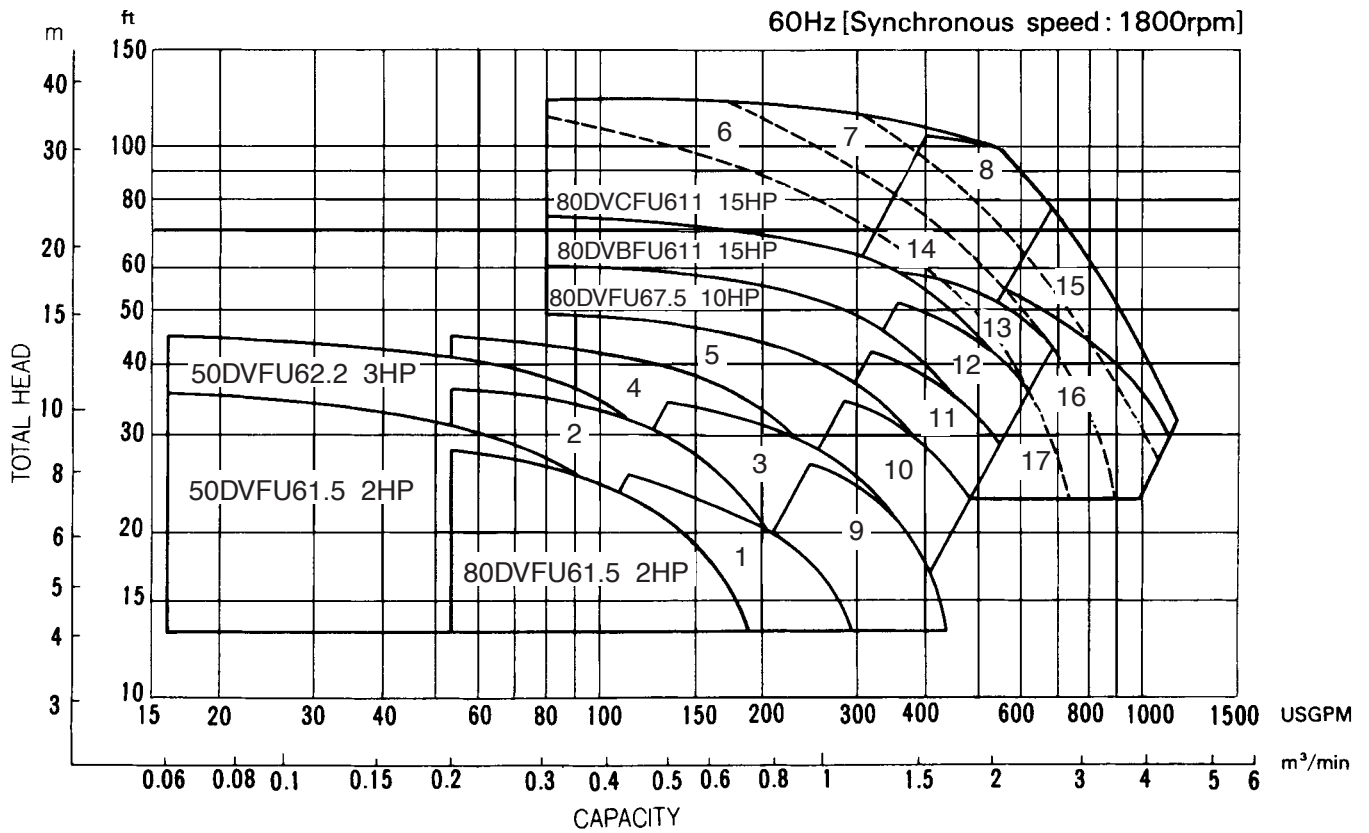

- |                   |                     |
|-------------------|---------------------|
| 1 80DVBFU62.2 3HP | 10 100DVFU65.5 7HP  |
| 2 80DVCFU62.2 3HP | 11 100DVFU67.5 10HP |
| 3 80DVBFU63.7 5HP | 12 100DVBFU611 15HP |
| 4 80DVCFU63.7 5HP | 13 100DVCFU611      |
| 5 80DVFU65.5 7HP  | 14 100DVCFU615      |
| 6 80DVFU615 20HP  | 15 150DVCFU622      |
| 7 80DVFU618 25HP  | 16 150DVBFU622      |
| 8 80DVFU622 30HP  | 17 150DVBFU622 15HP |
| 9 100DVFU63.7 5HP |                     |

**Specifications**

**A. General:**

Provide submersible recessed impeller, vortex type sewage pumps suitable for continuous duty operation underwater without loss of watertight integrity to a depth of 65 feet. Pump system design shall include a guide rail system be such that the pump will be automatically connected to the discharge piping when lowered into place on the discharge connection. The pump shall be easily removable for inspection or service, requiring no bolts, nuts, or other fasteners to be disconnected, or the need for personnel to enter the wet well. The motor and pump shall be designed, manufactured, and assembled by the same manufacturer.

**B. Manufacturer:**

EBARA International Corporation

**C. Pump Characteristics:**

Pumps shall conform to the following requirements:

|                                    |                     |
|------------------------------------|---------------------|
| Number of units                    |                     |
| Design flow (gpm)                  |                     |
| Design TDH (ft)                    |                     |
| Minimum shut off head (ft)         |                     |
| RPM                                | 1800                |
| Maximum HP                         |                     |
| Minimum efficiency at design (%)   |                     |
| Minimum power factor at design (%) |                     |
| Voltage/HZ                         | 208/230V, 460V / 60 |
| Phase                              | 3                   |

**D. Pump Construction:**

All major parts of the pumping unit(s) including casing, impeller, motor frame and discharge elbow shall be manufactured from gray cast iron, ASTM A-48 Class 30. Castings shall have smooth surfaces devoid of blow holes or other casting irregularities. Casing design shall be centerline discharge with a large radius on the cut water to prevent clogging. Units shall be furnished with a discharge elbow and 125 lb. flat face ANSI flange. All exposed bolts and nuts shall be 304 stainless steel. All mating surfaces of major components shall be machined and fitted with NBR O-rings where watertight sealing is required. Machining and fitting shall be such that sealing is accomplished by automatic compression of O-rings in two planes and O-ring contact is made on four surfaces without the requirement of specific torque limits. Internal and external surfaces are prepared to SPPC-VISI-SP-3-63 then coated with a zinc-chromate primer. The external surfaces are then coated with an H.B. Tnemecol 46-465 Coal Tar paint.

Impeller design shall be a semi-open recessed, vortex, multi-vane design, direct connected to the motor shaft with a slip fit, key driven, and secured with an impeller nut. The inlet edge of the impeller vanes shall be angled toward the impeller periphery so as to facilitate the release of objects that might otherwise clog the pump. The design shall also include back pump out vanes to reduce the pressure and entry of foreign materials into the mechanical seal area. In addition, a lip seal shall be located behind the impeller hub to further reduce the entry of foreign materials into the seal area on 7½ HP and above.

**1. Mechanical Seals:**

- a. For units 2 to 5 HP, double mechanical seals operating in an oil bath shall be provided on all units. The oil filled seal chamber shall be designed to prevent over-filling and include an anti-vortexing vane to insure proper lubrication of both seal faces. Lower face materials shall be silicon carbide, upper faces carbon vs. ceramic, NBR elastomers, and 304SS hardware. Seal system shall not rely on pumping medium for lubrication.
- b. Units 7½ to 30 HP shall be designed to include a double mechanical seal in a tandem arrangement. Each seal shall be positively driven and act independently with its own spring system. The upper seal operates in an oil bath, while the lower seal is lubricated by the oil from between the shaft and the seal faces, and in contact with the pumpage on the outside. Lower face materials shall be silicon carbide, upper faces carbon vs. ceramic, NBR elastomers, and 304SS hardware. Seal system shall not rely on pumping medium for lubrication.

## Specifications

---

### E. Motor Construction:

The pump motor shall be an air filled induction type with a squirrel cage rotor, shell type design, built to NEMA MG-1, Design B specifications. Stator windings shall be copper, insulated with moisture resistant Class H insulation, rated for 311°F. The stator shall be dipped and baked three times in Class H varnish and heat shrunk fitted into the stator housing. Rotor bars and short circuit rings shall be manufactured of cast aluminum. Motor shaft shall be one piece AISI403 for 2 to 5HP, AISI420 for 7½ to 30 HP material, rotating on two permanently lubricated ball bearings designed for a minimum B-10 life of 60,000 hours. Motor service factor shall be 1.15 and capable of up to 20 starts per hour. The motor shall be designed for continuous duty pumping at a maximum sump temperature of 104°F. Voltage and frequency tolerances shall be a maximum 10 / 5% respectively. Motor over temperature protection shall be provided by miniature thermal protectors embedded in the windings. Mechanical seal failure protection shall be provided by a mechanical float switch located in a chamber above the seal. This switch shall be comprised of a magnetic float that actuates a dry reed switch encapsulated within the stem. Should the mechanical seal fail, liquid shall be directed into the float chamber, in which the rising liquid activates the switch opening the normally closed circuit. For units 2 to 10HP the float body and float shall be a polypropylene material with a 316SS stopper. Units 15HP and greater, the float switch components shall be 304SS. The motor shall be non overloading over the entire specified range of operation and be able to operate at full load intermittently while unsubmerged without damage to the unit.

Power cable jacket shall be manufactured of an oil resistant chloroprene rubber material, designed for submerged applications. Cable shall be watertight to a depth of at least 65'. The cable entry system shall comprise of primary, secondary, and tertiary sealing methods. The primary seal shall be achieved by an cylindrical elastomeric grommet compressed between the motor cover and a 304SS washer. Secondary sealing is accomplished with a compressed O-ring made of NBR material. Compression and subsequent sealing shall preclude specific torque requirements. The system shall also include tertiary sealing to prevent leakage into the motor housing due to capillary action through the insulation if the cable is damaged or cut. The cable wires shall be cut, stripped, re-connected with a copper butt end connector, and embedded in epoxy within the cable gland. This provides a dead end for leakage through the cable insulation into the motor junction area.

### F. Guide Rail system:

Design shall include two (2) 304SS schedule 40 guide rails sized to mount directly to the quick discharge connector, QDC, at the floor of the wetwell and to a guide rail bracket at the top of the wetwell below the hatch opening, (refer to project drawings). Intermediate guide brackets are recommended for rail lengths over 15 feet.

Guide rails are not part of the pump package and shall be supplied by others.

The QDC shall be manufactured of cast iron, A48 Class 30. It shall be designed to adequately support the guide rails, discharge piping, and pumping unit under both static and dynamic loading conditions with support legs that are suitable for anchoring it to the wetwell floor. The face of the inlet QDC flange shall be perpendicular to the floor of the wetwell. The discharge flange of the QDC shall conform to ANSI B16.1 Class 125.

The pump design shall include an integral self-aligning sliding bracket. Sealing of the pumping unit to the QDC shall be accomplished by a single, linear, downward motion of the pump. The entire weight of the pump unit shall be guided to and wedged tightly against the inlet flange of the QDC, making metal to metal contact with the pump discharge forming a seal without the use of bolts, gaskets or O-rings.

A stainless steel lifting chain of adequate length for removing and installing the pump unit is recommended. The chain shall have a round link with a 2-¼" inside diameter every two feet. This link will allow for a sliding pinch bar through the link to pick the chain, more than once if necessary, at multiple intervals during pump removal and installation.



**Specifications**

**A. General:**

Provide FM explosion proof submersible recessed impeller vortex type sewage pumps suitable for continuous duty operation underwater without loss of watertight integrity to a depth of 65 feet. Pump system design shall include a guide rail system be such that the pump will be automatically connected to the discharge piping when lowered into place on the discharge connection. The pump shall be easily removable for inspection or service, requiring no bolts, nuts, or other fasteners to be disconnected, or the need for personnel to enter the wet well. The motor and pump shall be designed, manufactured, and assembled by the same manufacturer.

**B. Manufacturer:**

EBARA International Corporation

**C. Pump Characteristics:**

Pumps shall conform to the following requirements:

|                                    |                     |
|------------------------------------|---------------------|
| Number of units                    |                     |
| Design flow (gpm)                  |                     |
| Design TDH (ft)                    |                     |
| Minimum shut off head (ft)         |                     |
| RPM                                | 1800                |
| Maximum HP                         |                     |
| Minimum efficiency at design (%)   |                     |
| Minimum power factor at design (%) |                     |
| Voltage/HZ                         | 208/230V, 460V / 60 |
| Phase                              | 3                   |

**D. Pump Construction:**

All major parts of the pumping unit(s) including casing, impeller, motor frame and discharge elbow shall be manufactured from gray cast iron, ASTM A-48 Class 30. Castings shall have smooth surfaces devoid of blow holes or other casting irregularities. Casing design shall be centerline discharge with a large radius on the cut water to prevent clogging. Units shall be furnished with a discharge elbow and 125 lb. flat face ANSI flange. All exposed bolts and nuts shall be 304 stainless steel. All mating surfaces of major components shall be machined and fitted with NBR O-rings where watertight sealing is required. Machining and fitting shall be such that sealing is accomplished by automatic compression of O-rings in two planes and O-ring contact is made on four surfaces without the requirement of specific torque limits. Internal and external surfaces are prepared to SPPC-VISI-SP-3-63 then coated with a zinc-chromate primer. The external surfaces are then coated with an H.B. Tnemecol 46-465 Coal Tar paint.

Impeller design shall be a semi-open, recessed, vortex, multi-vane design, direct connected to the motor shaft with a slip fit, key driven, and secured with an impeller nut. The inlet edge of the impeller vanes shall be angled toward the impeller periphery so as to facilitate the release of objects that might otherwise clog the pump. The design shall also include back pump out vanes to reduce the pressure and entry of foreign materials into the mechanical seal area. In addition, a lip seal shall be located behind the impeller hub to further reduce the entry of foreign materials into the seal area on 7½ HP and above.

**1. Mechanical Seals:**

- a. For units 2 to 5 HP, double mechanical seals operating in an oil bath shall be provided on all units. The oil filled seal chamber shall be designed to prevent over-filling and include an anti-vortexing vane to insure proper lubrication of both seal faces. Lower face materials shall be silicon carbide, upper faces carbon vs. ceramic, NBR elastomers, and 304SS hardware. Seal system shall not rely on pumping medium for lubrication.
- b. Units 7½ to 30 HP shall be designed to include a double mechanical seal in a tandem arrangement. Each seal shall be positively driven and act independently with its own spring system. The upper seal operates in an oil bath, while the lower seal is lubricated by the oil from between the shaft and the seal faces, and in contact with the pumpage on the outside. Lower face materials shall be silicon carbide, upper faces carbon vs. ceramic, NBR elastomers, and 304SS hardware. Seal system shall not rely on pumping medium for lubrication.



**Specifications****E. Motor Construction:**

The pump motor shall be FM Explosion Proof, Class 1, Division 1, Groups C, D. The design shall be an air filled induction type with a squirrel cage rotor, shell type design, built to NEMA MG-1, Design B specifications. Stator windings shall be copper, insulated with moisture resistant Class H insulation, rated for 311°F. The stator shall be dipped and baked three times in Class H varnish and heat shrunk fitted into the stator housing. Rotor bars and short circuit rings shall be manufactured of cast aluminum. Motor shaft shall be one piece AISI403 for 2 to 5HP, AISI420 for 7½ to 30HP material, rotating on two permanently lubricated ball bearings designed for a minimum B-10 life of 60,000 hours. Motor service factor shall be 1.15 and capable of up to 20 starts per hour. The motor shall be designed for continuous duty pumping at a maximum sump temperature of 104°F. Voltage and frequency tolerances shall be a maximum 10 / 5% respectively. Motor over temperature protection shall be provided by miniature thermal protectors embedded in the windings. Mechanical seal failure protection shall be provided by a mechanical float switch located in a chamber above the seal. This switch shall be comprised of a magnetic float that actuates a dry reed switch encapsulated within the stem. Should the mechanical seal fail, liquid shall be directed into the float chamber, in which the rising liquid activates the switch opening the normally closed circuit. For units 2 to 10HP the float body and float shall be a polypropylene material with a 316SS stopper. Units 15HP and greater, the float switch components shall be 304SS. The motor shall be non overloading over the entire specified range of operation and be able to operate at full load intermittently while unsubmerged without damage to the unit.

Power cable jacket shall be manufactured of an oil resistant chloroprene rubber material, designed for submerged applications. Cable shall be watertight to a depth of at least 65'. The cable entry system shall comprise of primary, secondary, and tertiary sealing methods. The primary seal shall be achieved by an cylindrical elastomeric grommet compressed between the motor cover and a 304SS washer. Secondary sealing is accomplished with a compressed O-ring made of NBR material. Compression and subsequent sealing shall preclude specific torque requirements. The system shall also include tertiary sealing to prevent leakage into the motor housing due to capillary action through the insulation if the cable is damaged or cut. The cable wires shall be cut, stripped, re-connected with a copper butt end connector, and embedded in epoxy within the cable gland. This provides a dead end for leakage through the cable insulation into the motor junction area.

**F. Guide Rail system:**

Design shall include two (2) 304SS schedule 40 guide rails sized to mount directly to the quick discharge connector, QDC, at the floor of the wetwell and to a guide rail bracket at the top of the wetwell below the hatch opening, (refer to project drawings). Intermediate guide brackets are recommended for rail lengths over 15 feet. Guide rails are not part of the pump package and shall be supplied by others.

The QDC shall be manufactured of cast iron, A48 Class 30. It shall be designed to adequately support the guide rails, discharge piping, and pumping unit under both static and dynamic loading conditions with support legs that are suitable for anchoring it to the wetwell floor. The face of the inlet QDC flange shall be perpendicular to the floor of the wetwell. The discharge flange of the QDC shall conform to ANSI B16.1 Class 125.

The pump design shall include an integral self-aligning sliding bracket. Sealing of the pumping unit to the QDC shall be accomplished by a single, linear, downward motion of the pump. The entire weight of the pump unit shall be guided to and wedged tightly against the inlet flange of the QDC, making metal to metal contact with the pump discharge forming a seal without the use of bolts, gaskets or O-rings.

A stainless steel lifting chain of adequate length for removing and installing the pump unit is recommended. The chain shall have a round link with a 2-¼" inside diameter every two feet. This link will allow for a sliding pinch bar through the link to pick the chain, more than once if necessary, at multiple intervals during pump removal and installation.





**Performance Curves**

Project: \_\_\_\_\_ GPM: \_\_\_\_\_ TDH: \_\_\_\_\_ EFF: \_\_\_\_\_ HP: \_\_\_\_\_ Chk'd: \_\_\_\_\_ Date: \_\_\_\_\_

**50DVF61.5 (2HP) Synchronous Speed: 1800 RPM**

**2 inch Discharge**

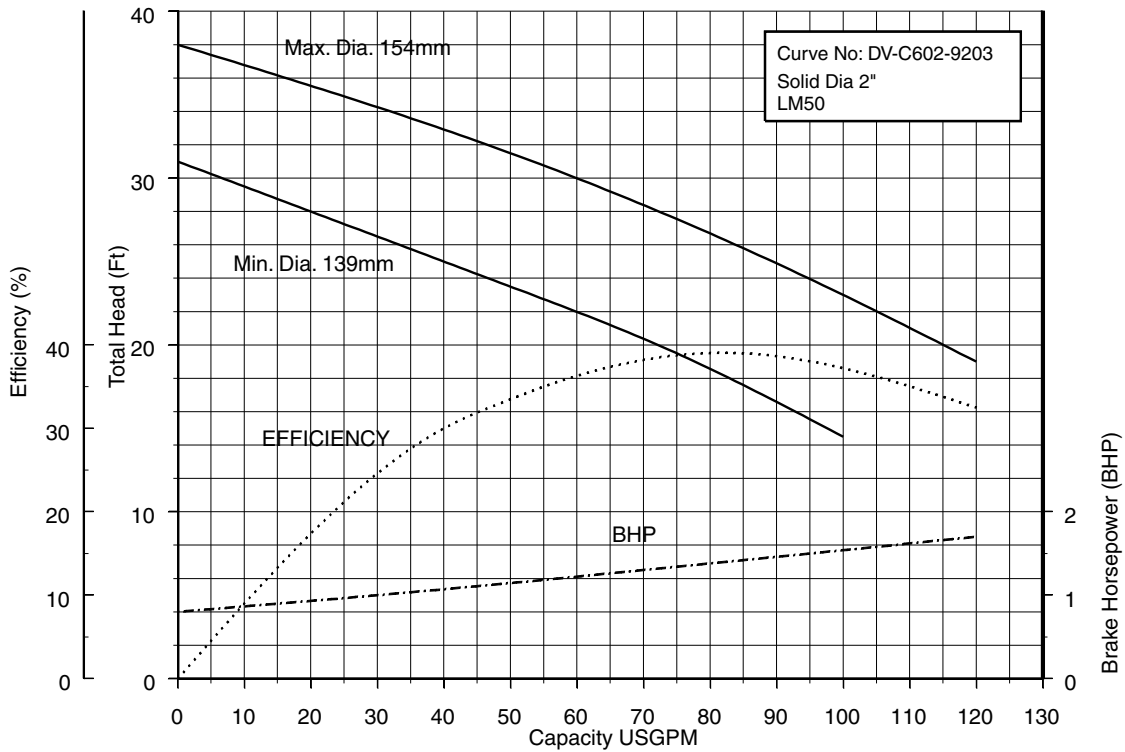

**50DVF62.2 (3HP) Synchronous Speed: 1800 RPM**

**2 inch Discharge**

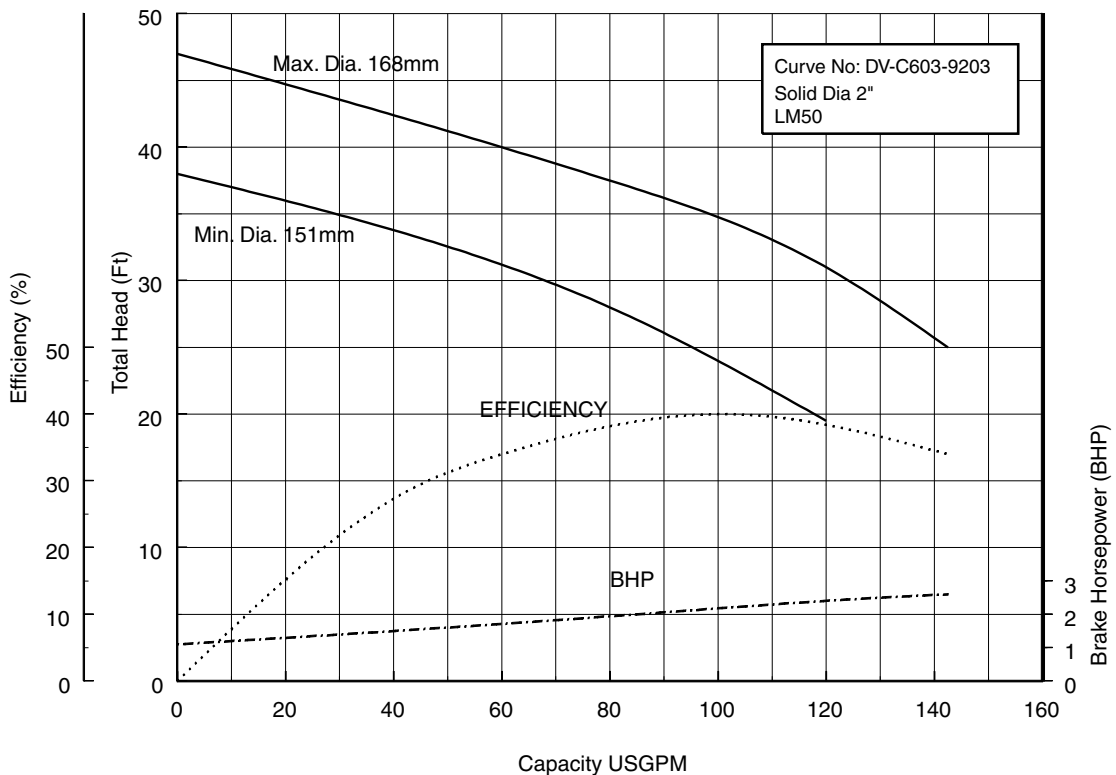

**Performance Curves**

Project: \_\_\_\_\_ GPM: \_\_\_\_\_ TDH: \_\_\_\_\_ EFF: \_\_\_\_\_ HP: \_\_\_\_\_ Chk'd: \_\_\_\_\_ Date: \_\_\_\_\_

**80DVF61.5 (2HP) Synchronous Speed: 1800 RPM**

**2, 3 inch Discharge**

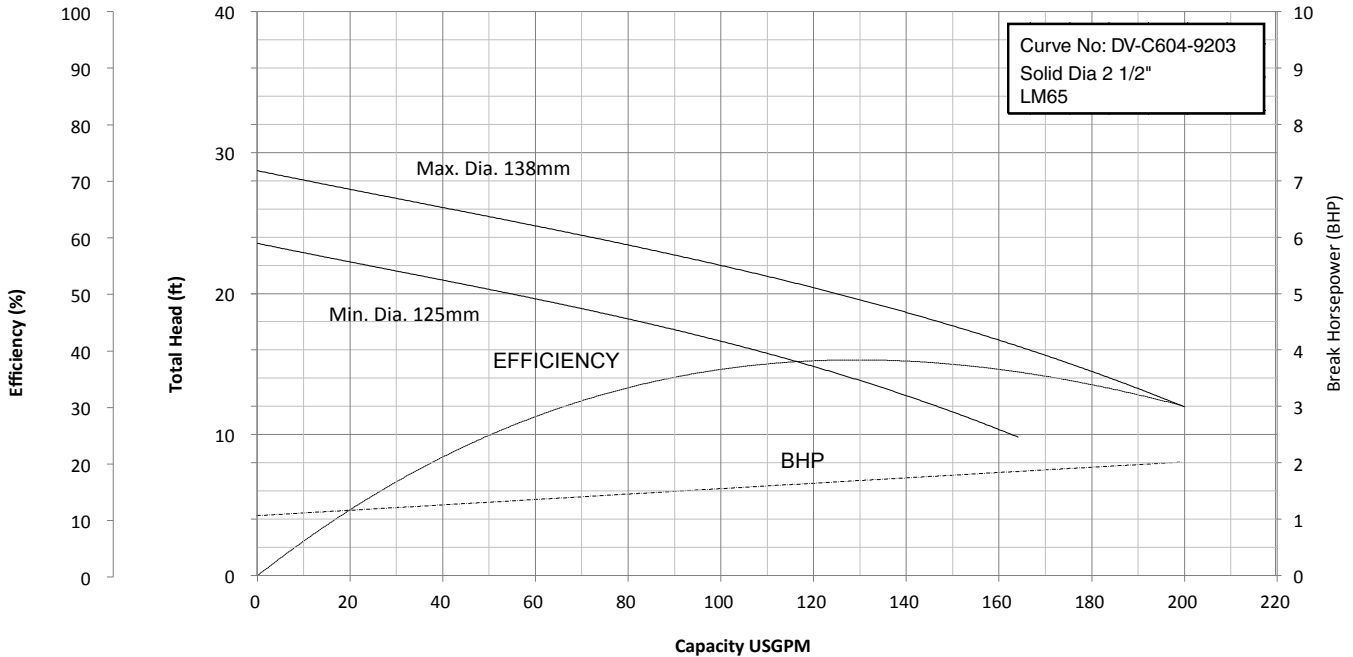

**80DVBF62.2 (3HP) Synchronous Speed: 1800 RPM**

**3, 4 inch Discharge**

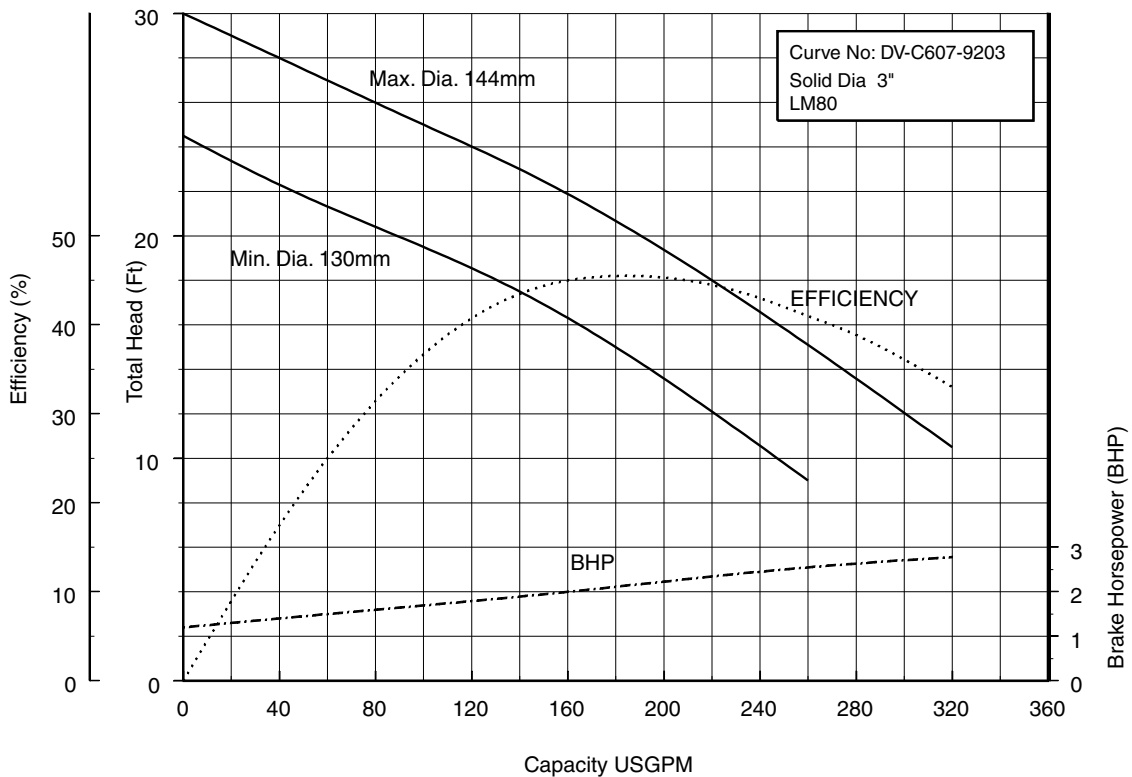

**Performance Curves**

Project: \_\_\_\_\_ GPM: \_\_\_\_\_ TDH: \_\_\_\_\_ EFF: \_\_\_\_\_ HP: \_\_\_\_\_ Chk'd: \_\_\_\_\_ Date: \_\_\_\_\_

**80DVCF62.2 (3HP) Synchronous Speed: 1800 RPM**

**2, 3 inch Discharge**

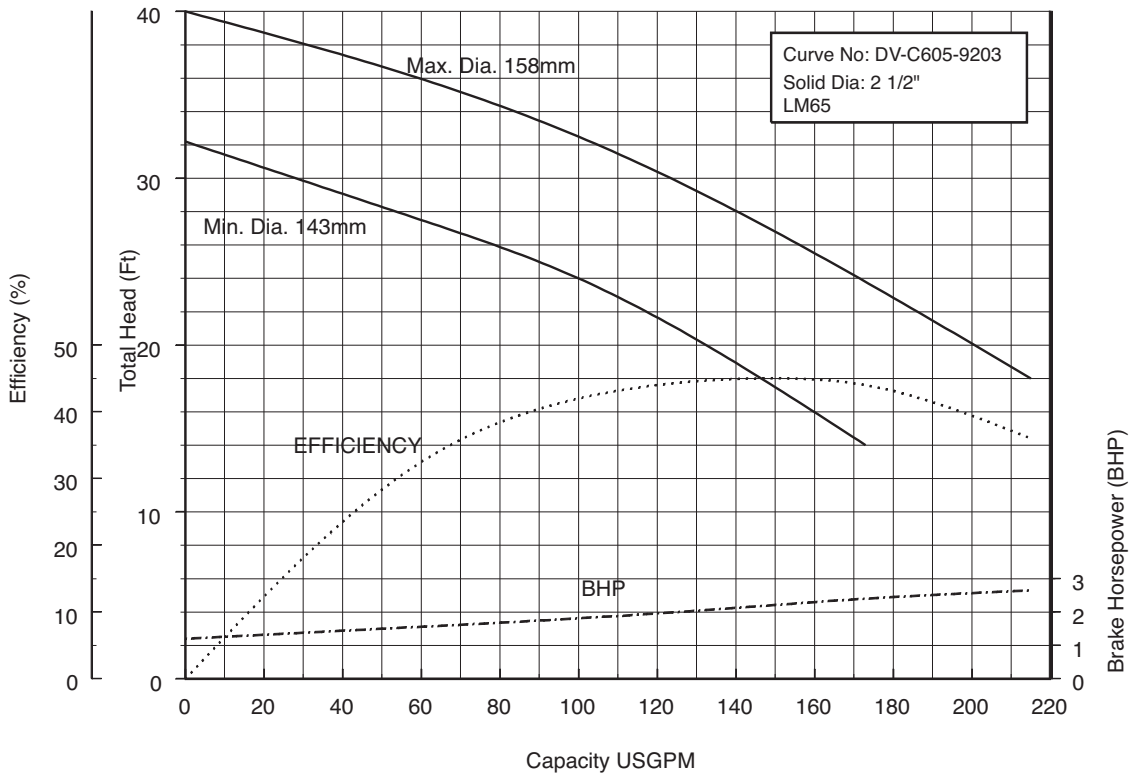

**80DVBF63.7 (5HP) Synchronous Speed: 1800 RPM**

**3, 4 inch Discharge**

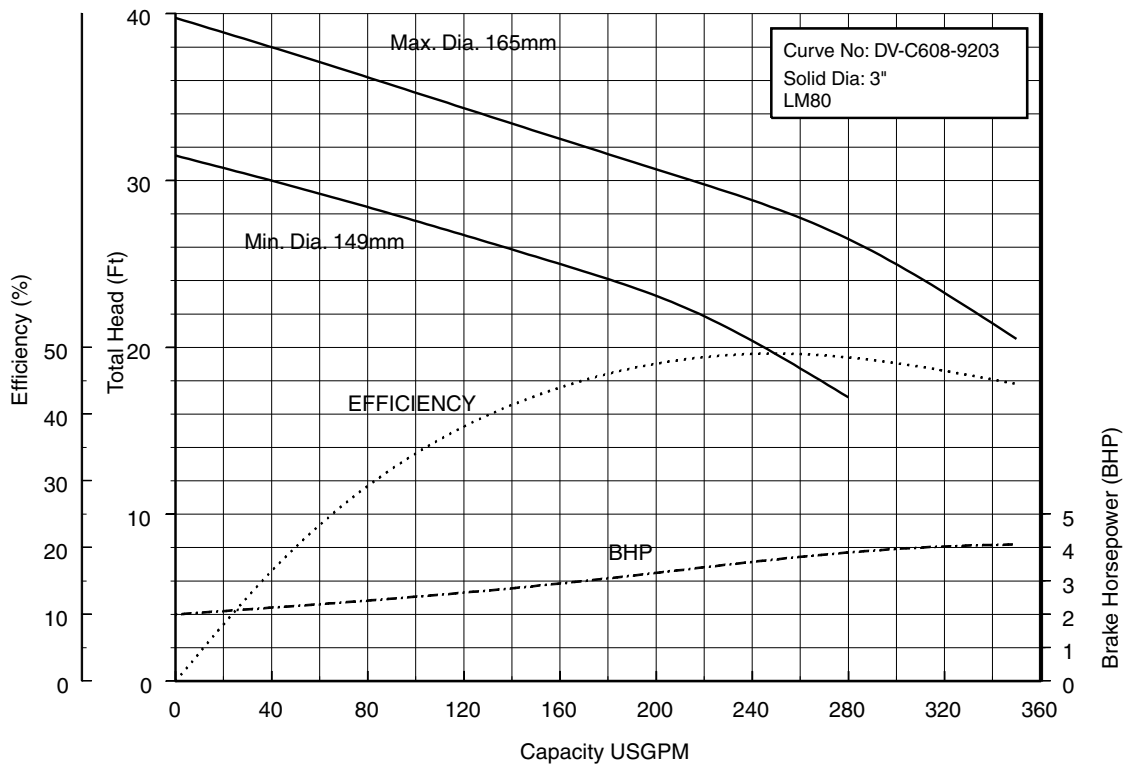

**Performance Curves**

Project: \_\_\_\_\_ GPM: \_\_\_\_\_ TDH: \_\_\_\_\_ EFF: \_\_\_\_\_ HP: \_\_\_\_\_ Chk'd: \_\_\_\_\_ Date: \_\_\_\_\_

**80DVCF63.7 (5HP) Synchronous Speed: 1800 RPM**

**2, 3 inch Discharge**

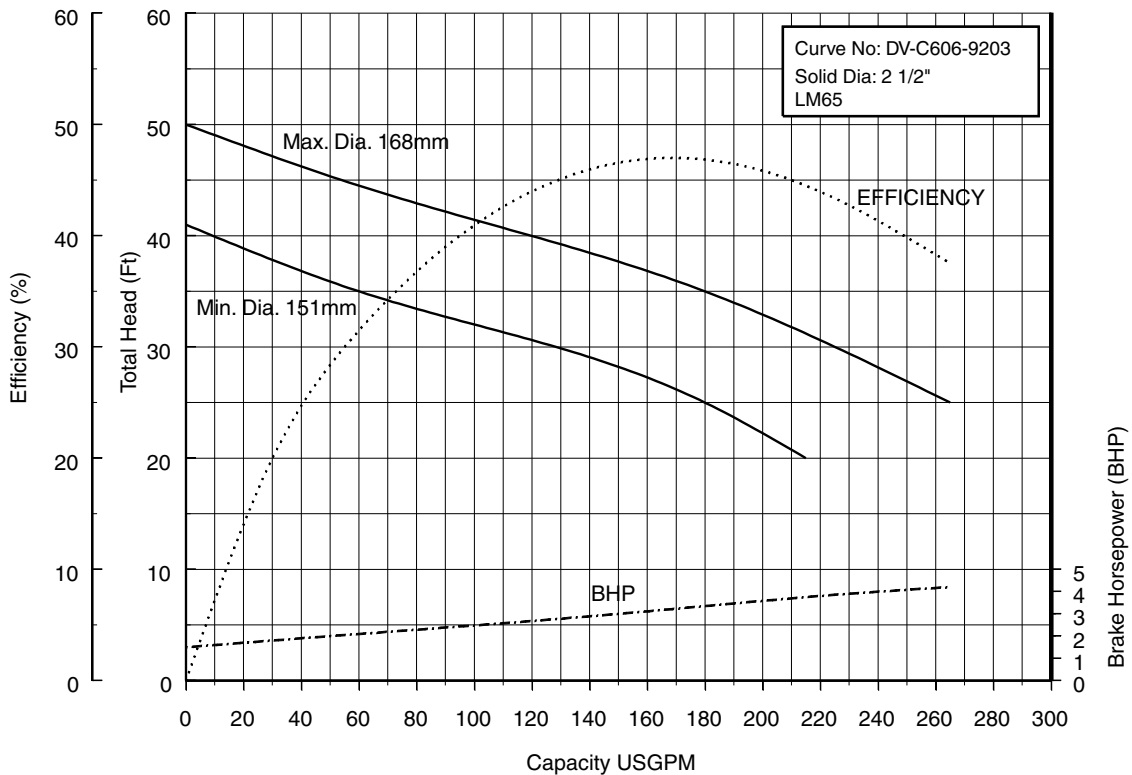

**80DVF65.5 (7 1/2HP) Synchronous Speed: 1800 RPM**

**3, 4 inch Discharge**

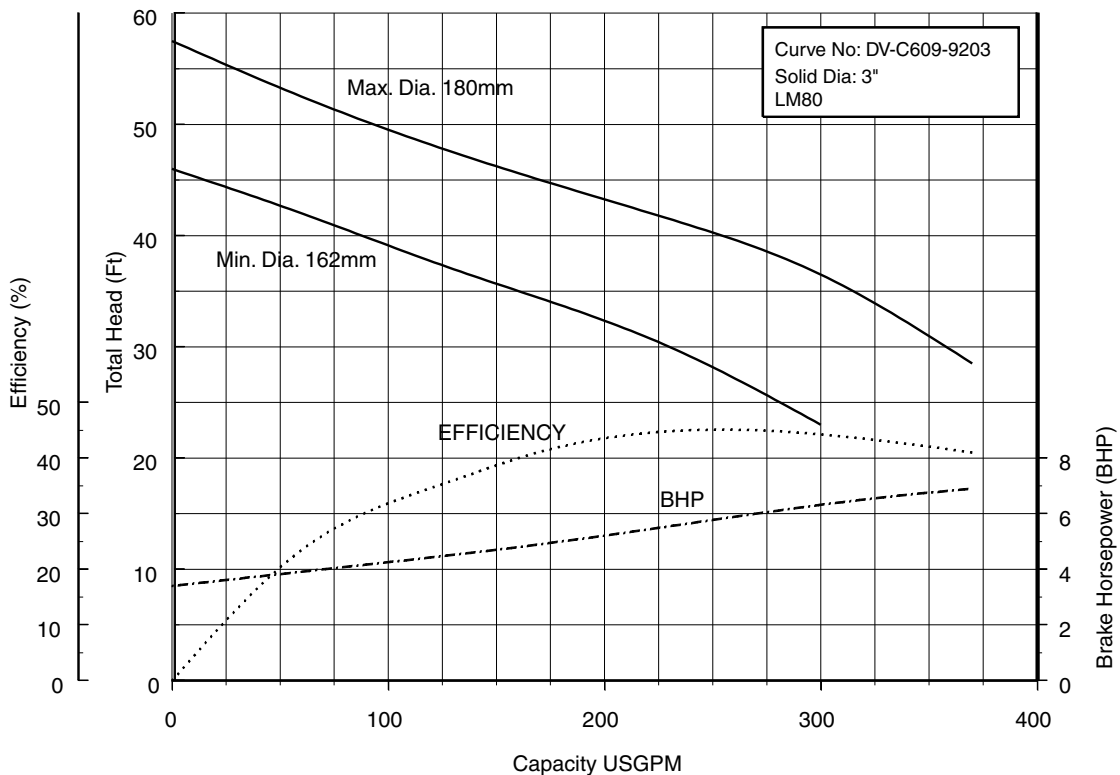

**Performance Curves**

Project: \_\_\_\_\_ GPM: \_\_\_\_\_ TDH: \_\_\_\_\_ EFF: \_\_\_\_\_ HP: \_\_\_\_\_ Chk'd: \_\_\_\_\_ Date: \_\_\_\_\_

**80DVF67.5 (10HP) Synchronous Speed: 1800 RPM**

**3, 4 inch Discharge**

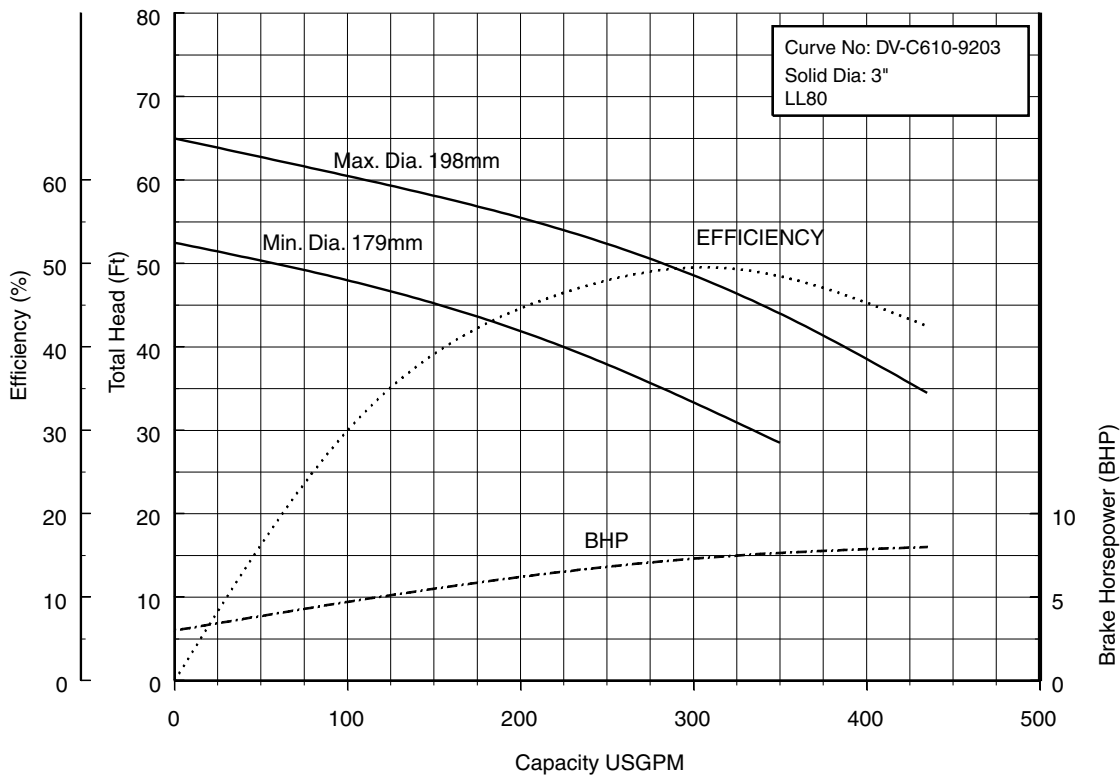

**80DVBF611 (15HP) Synchronous Speed: 1800 RPM**

**3, 4 inch Discharge**

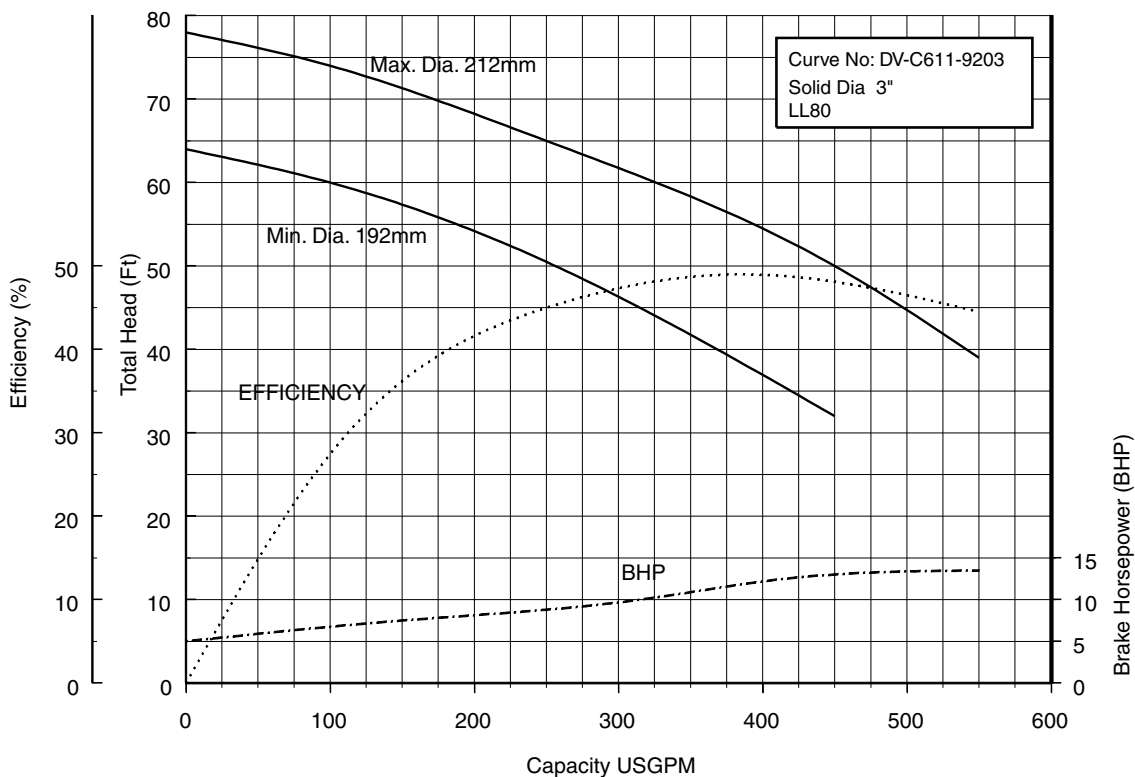

**Performance Curves**

Project: \_\_\_\_\_ GPM: \_\_\_\_\_ TDH: \_\_\_\_\_ EFF: \_\_\_\_\_ HP: \_\_\_\_\_ Chk'd: \_\_\_\_\_ Date: \_\_\_\_\_

**80DVCF611 TO 622 (15 to 30 HP) Synchronous Speed: 1800 RPM 3, 4 inch Discharge**

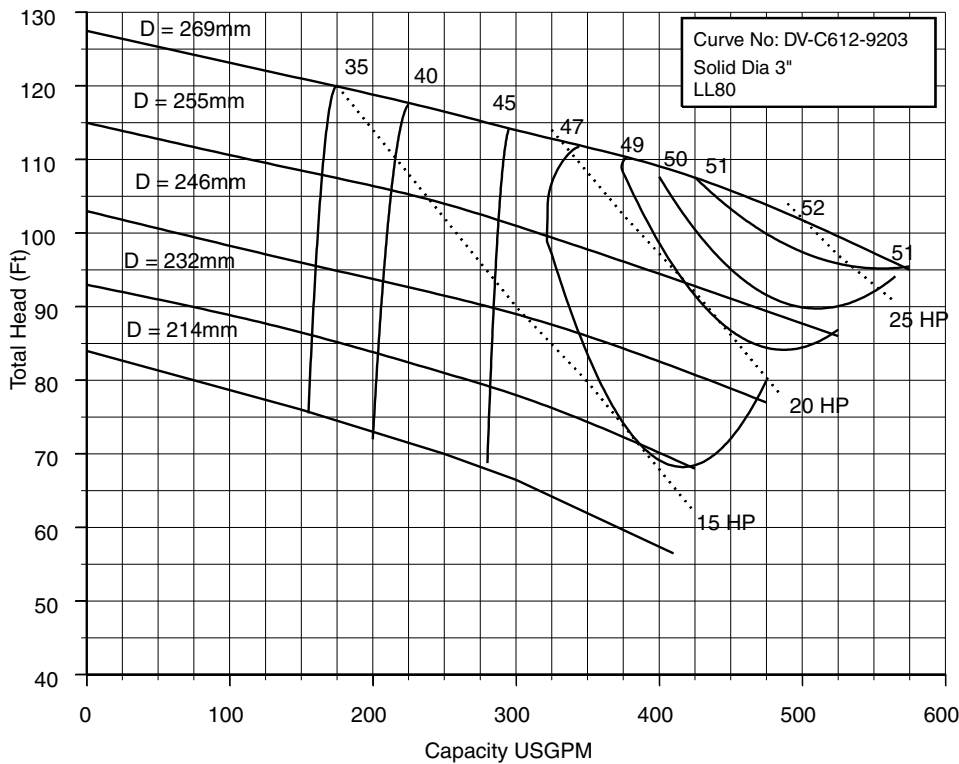

**100DVF63.7 (5HP) Synchronous Speed: 1800 RPM**

**3, 4 inch Discharge**

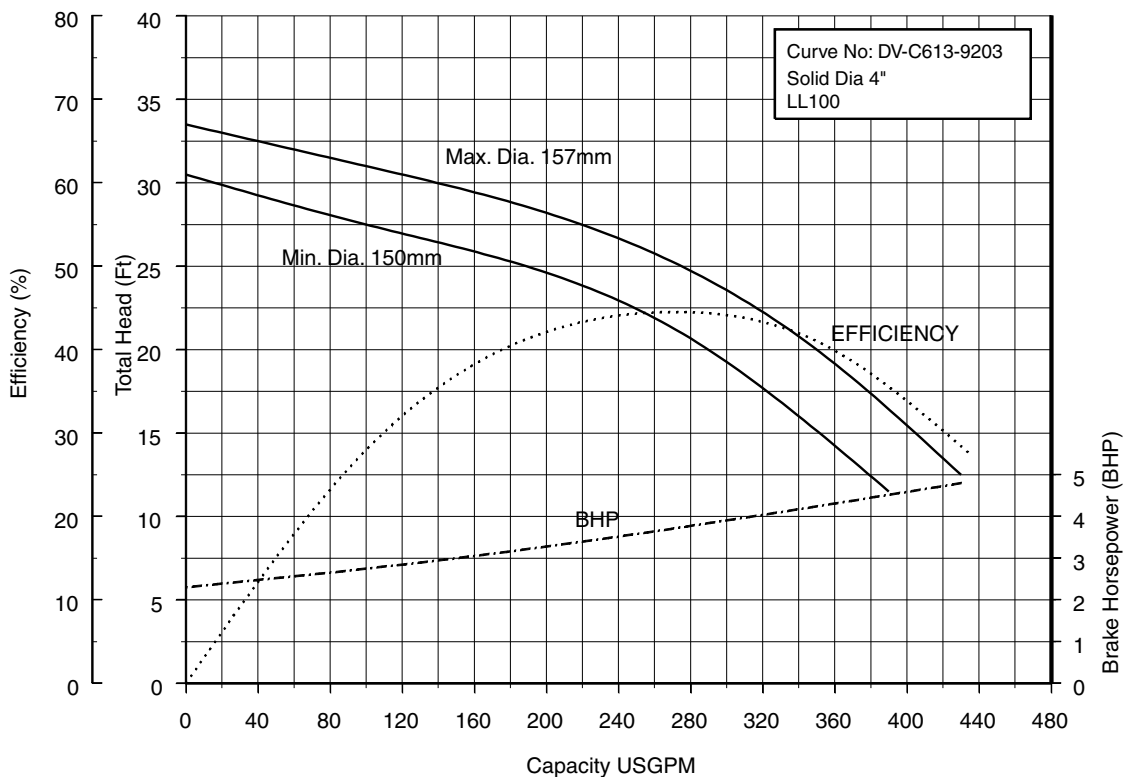

**Performance Curves**

Project: \_\_\_\_\_ GPM: \_\_\_\_\_ TDH: \_\_\_\_\_ EFF: \_\_\_\_\_ HP: \_\_\_\_\_ Chk'd: \_\_\_\_\_ Date: \_\_\_\_\_

**100DVF65.5 (7½HP) Synchronous Speed: 1800 RPM**

**3, 4 inch Discharge**

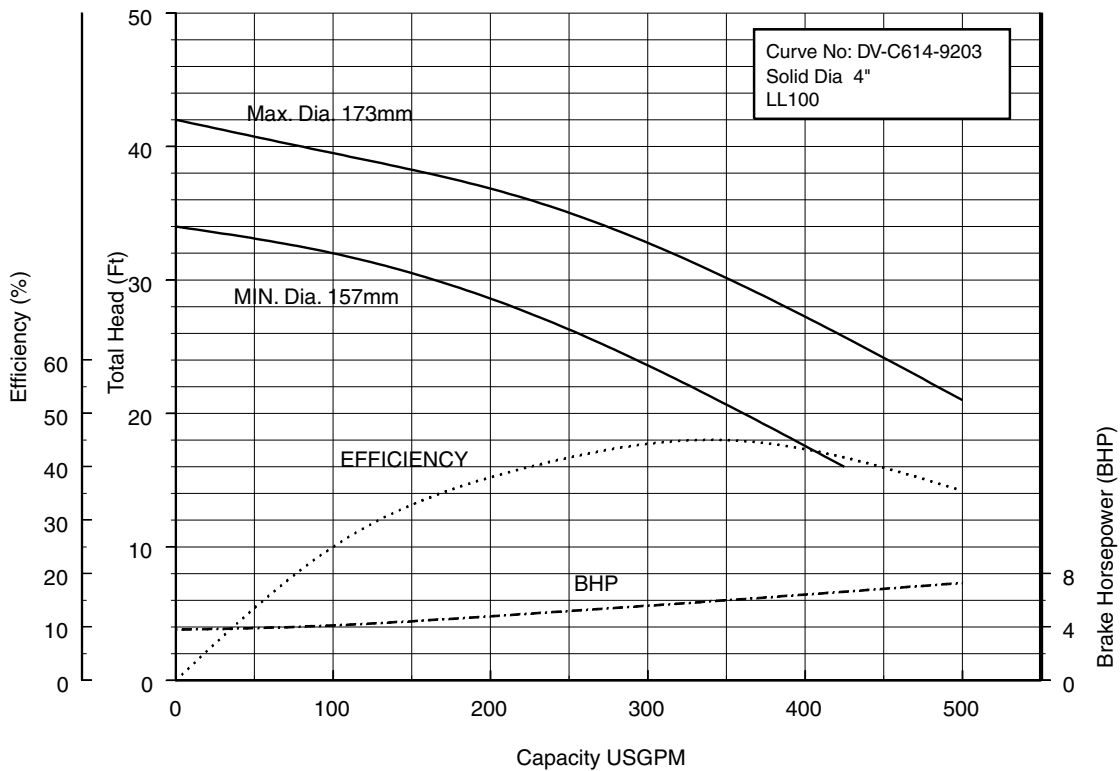

**100DVF67.5 (10HP) Synchronous Speed: 1800 RPM**

**3, 4 inch Discharge**

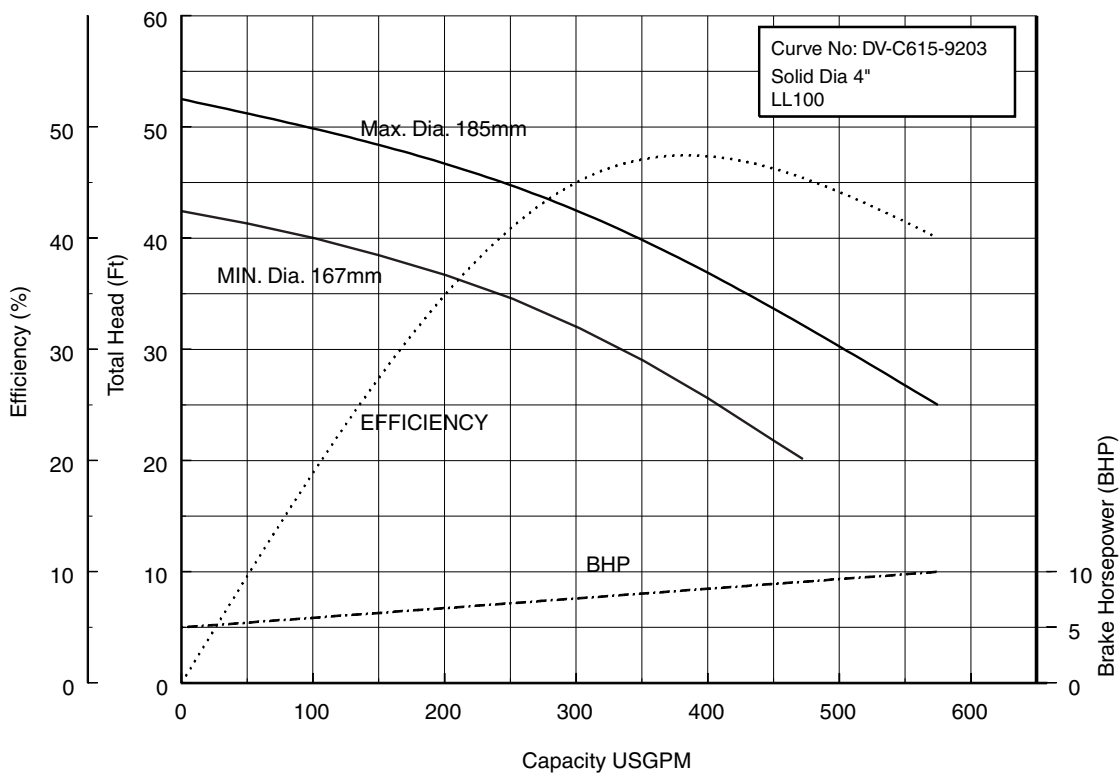

**Performance Curves**

Project: \_\_\_\_\_ GPM: \_\_\_\_\_ TDH: \_\_\_\_\_ EFF: \_\_\_\_\_ HP: \_\_\_\_\_ Chk'd: \_\_\_\_\_ Date: \_\_\_\_\_

**100DVBF611 (15HP) Synchronous Speed: 1800 RPM**

**3, 4 inch Discharge**

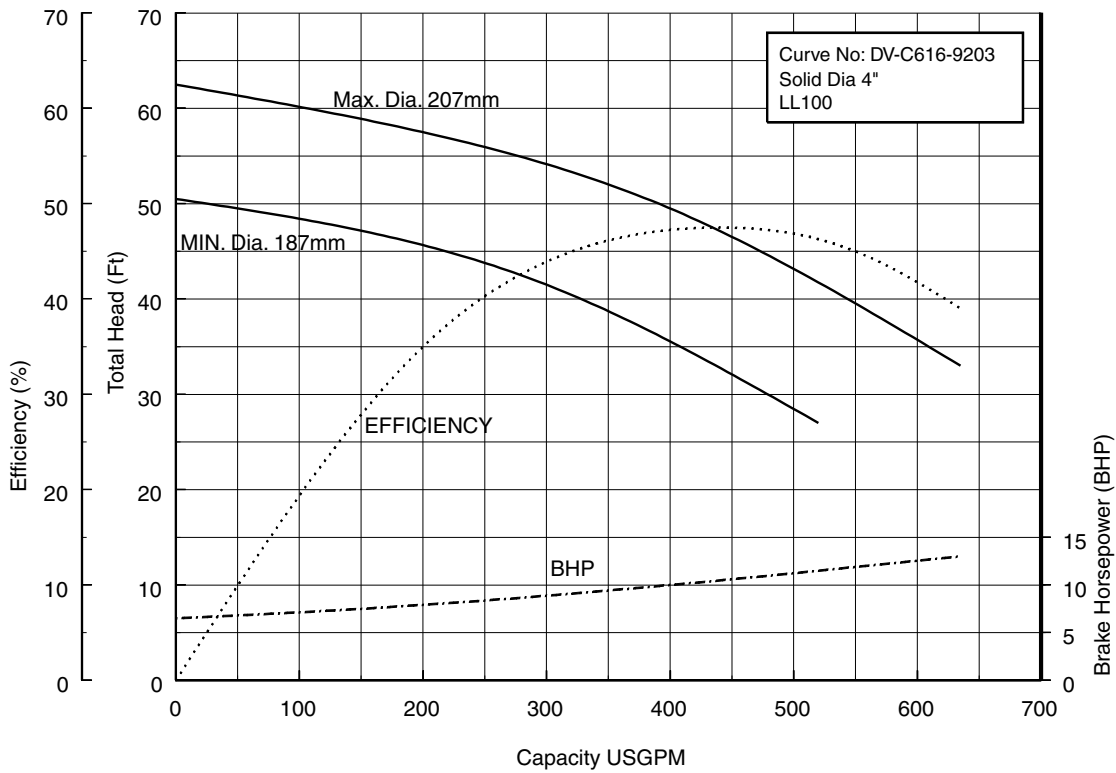

**100DVCF611 to 615 (15 to 20HP) Synchronous Speed: 1800 RPM 3, 4 inch Discharge**

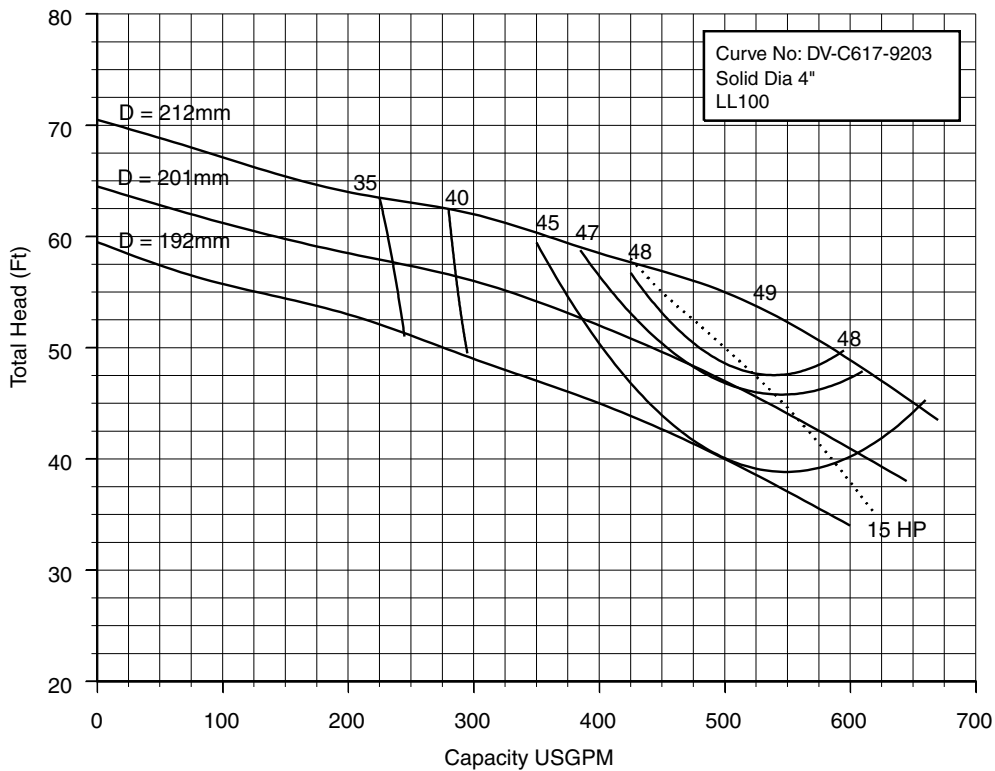



**Performance Curves**

Project: \_\_\_\_\_ GPM: \_\_\_\_\_ TDH: \_\_\_\_\_ EFF: \_\_\_\_\_ HP: \_\_\_\_\_ Chk'd: \_\_\_\_\_ Date: \_\_\_\_\_

**100DVDF611 to 622 (15 to 30HP) Synchronous Speed: 1800 RPM 3, 4 inch Discharge**

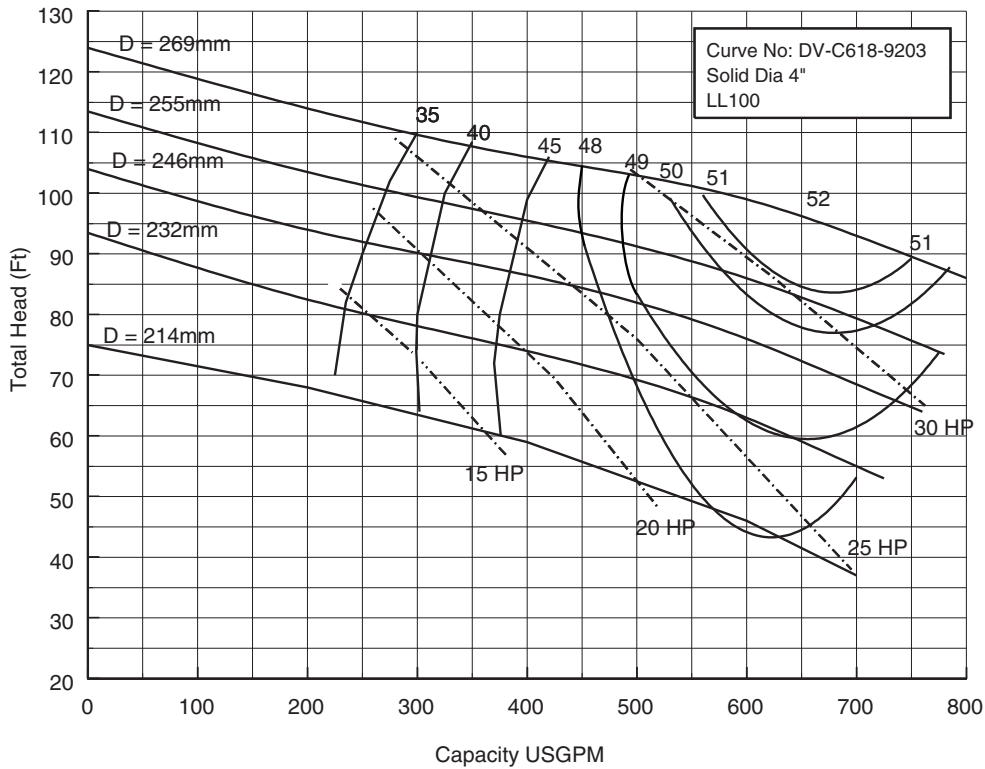

**150DVBF611 to 622 (15 to 30HP) Synchronous Speed: 1800 RPM 4, 6 inch Discharge**

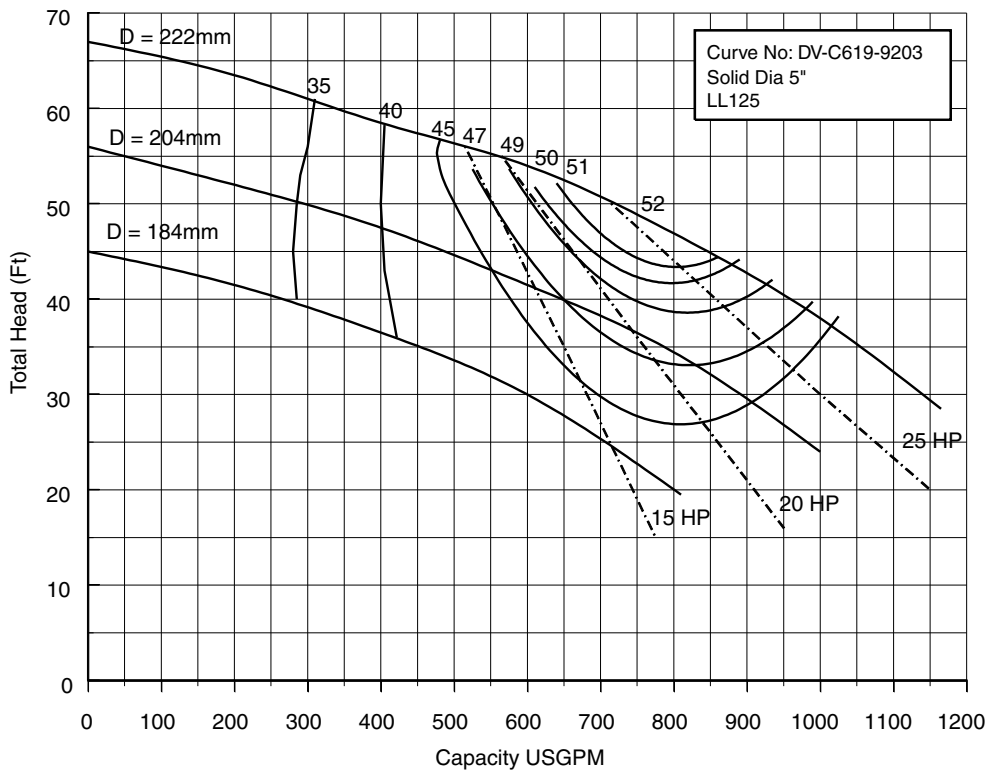

**Performance Curves**

Project: \_\_\_\_\_ GPM: \_\_\_\_\_ TDH: \_\_\_\_\_ EFF: \_\_\_\_\_ HP: \_\_\_\_\_ Chk'd: \_\_\_\_\_ Date: \_\_\_\_\_

**150DVCF618 to 622 (25 to 30HP) Synchronous Speed: 1800 RPM 4, 6 inch Discharge**

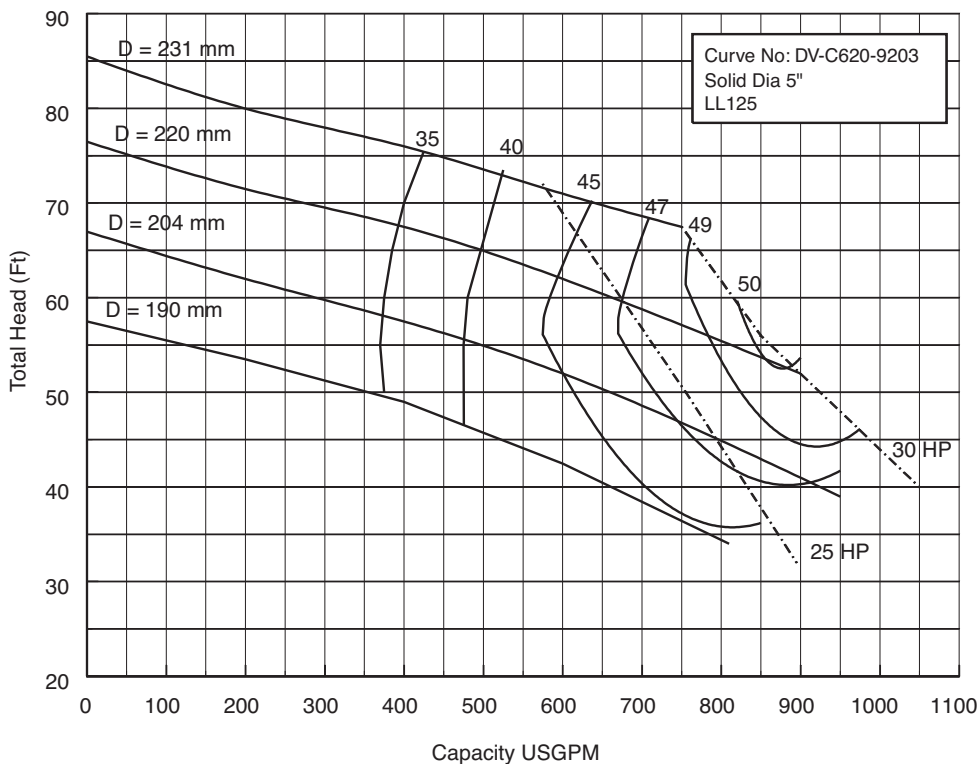

**Dimensions**

Project: \_\_\_\_\_ Model: \_\_\_\_\_ Chk'd: \_\_\_\_\_ Date: \_\_\_\_\_

**Model DVFU  
50DVFU, 2 to 3HP**

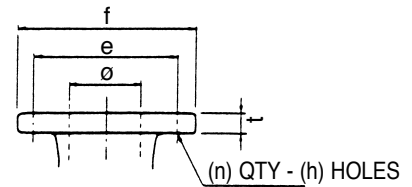
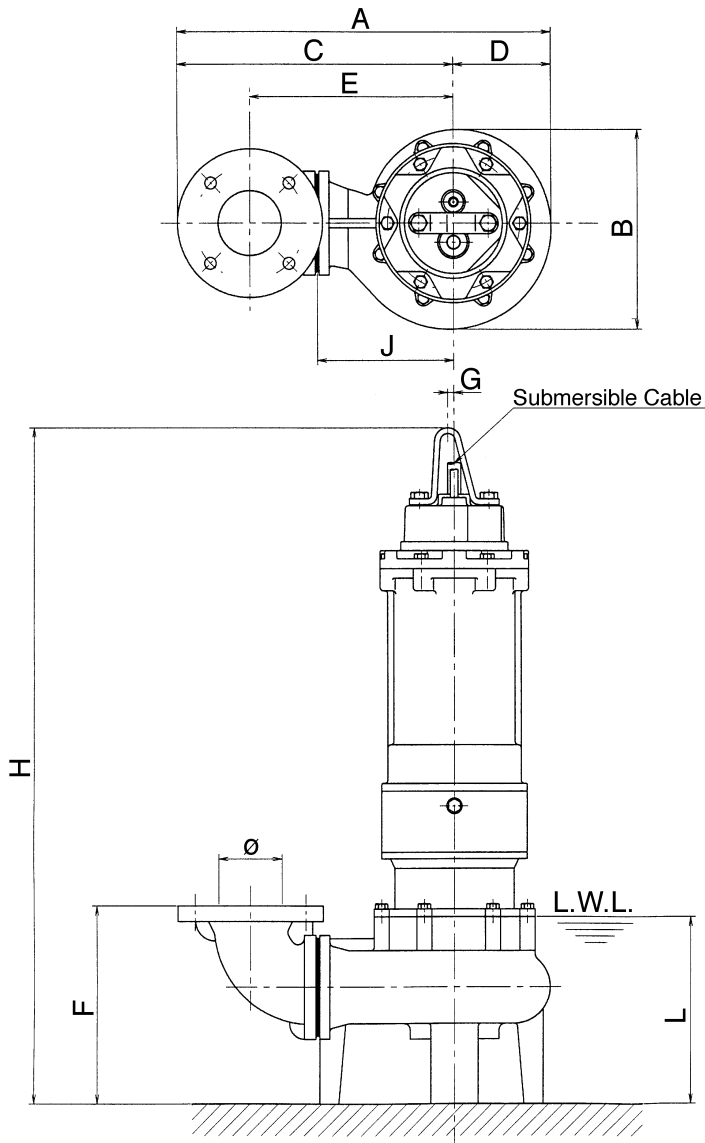

**Flange (ANSI 125 PSI F.F)**

| inch |                               |     |                               |   |                               |
|------|-------------------------------|-----|-------------------------------|---|-------------------------------|
| ø    | e                             | f   | t                             | n | h                             |
| 2    | 4 <sup>3</sup> / <sub>4</sub> | 6   | 5 <sup>5</sup> / <sub>8</sub> | 4 | 3 <sup>3</sup> / <sub>4</sub> |
| mm   |                               |     |                               |   |                               |
| ø    | e                             | f   | t                             | n | h                             |
| 50   | 121                           | 152 | 16                            | 4 | 19                            |

**Dimensions: inch**

| PHASE | SIZE<br>ø | MODEL      | OUTPUT |    | PUMP & MOTOR                   |                               |                                 |                                 |                                |                                |                                |    |                               |                               | WEIGHT<br>Lb |
|-------|-----------|------------|--------|----|--------------------------------|-------------------------------|---------------------------------|---------------------------------|--------------------------------|--------------------------------|--------------------------------|----|-------------------------------|-------------------------------|--------------|
|       |           |            | KW     | HP | A                              | B                             | C                               | D                               | E                              | F                              | G                              | H  | J                             | L                             |              |
| THREE | 2         | 50DVFU61.5 | 1.5    | 2  | 15 <sup>3</sup> / <sub>4</sub> | 9 <sup>3</sup> / <sub>8</sub> | 11 <sup>1</sup> / <sub>16</sub> | 4 <sup>11</sup> / <sub>16</sub> | 8 <sup>1</sup> / <sub>16</sub> | 7 <sup>5</sup> / <sub>16</sub> | 5 <sup>5</sup> / <sub>16</sub> | 28 | 5 <sup>7</sup> / <sub>8</sub> | 6 <sup>7</sup> / <sub>8</sub> | 121          |
|       |           | 50DVFU62.2 | 2.2    | 3  | 15 <sup>3</sup> / <sub>4</sub> | 9 <sup>3</sup> / <sub>8</sub> | 11 <sup>1</sup> / <sub>16</sub> | 4 <sup>11</sup> / <sub>16</sub> | 8 <sup>1</sup> / <sub>16</sub> | 7 <sup>5</sup> / <sub>16</sub> | 5 <sup>5</sup> / <sub>16</sub> | 29 | 5 <sup>7</sup> / <sub>8</sub> | 6 <sup>7</sup> / <sub>8</sub> | 150          |

**Dimensions: mm**

| PHASE | SIZE<br>ø | MODEL      | OUTPUT |    | PUMP & MOTOR |     |     |     |     |     |   |     |     |     | WEIGHT<br>kg |
|-------|-----------|------------|--------|----|--------------|-----|-----|-----|-----|-----|---|-----|-----|-----|--------------|
|       |           |            | KW     | HP | A            | B   | C   | D   | E   | F   | G | H   | J   | L   |              |
| THREE | 50        | 50DVFU61.5 | 1.5    | 2  | 400          | 238 | 281 | 119 | 205 | 185 | 8 | 711 | 150 | 175 | 55           |
|       |           | 50DVFU62.2 | 2.2    | 3  | 400          | 238 | 281 | 119 | 205 | 185 | 8 | 737 | 150 | 175 | 68           |

**Dimensions**

Project: \_\_\_\_\_ Model: \_\_\_\_\_ Chk'd: \_\_\_\_\_ Date: \_\_\_\_\_

**Model DVFU**  
**80DVFU, 2, 7½, 10HP**  
**80DVBFU, 3 to 5HP**  
**80DVCFU, 3 to 5HP**

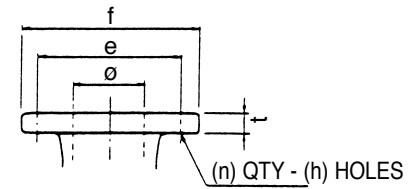
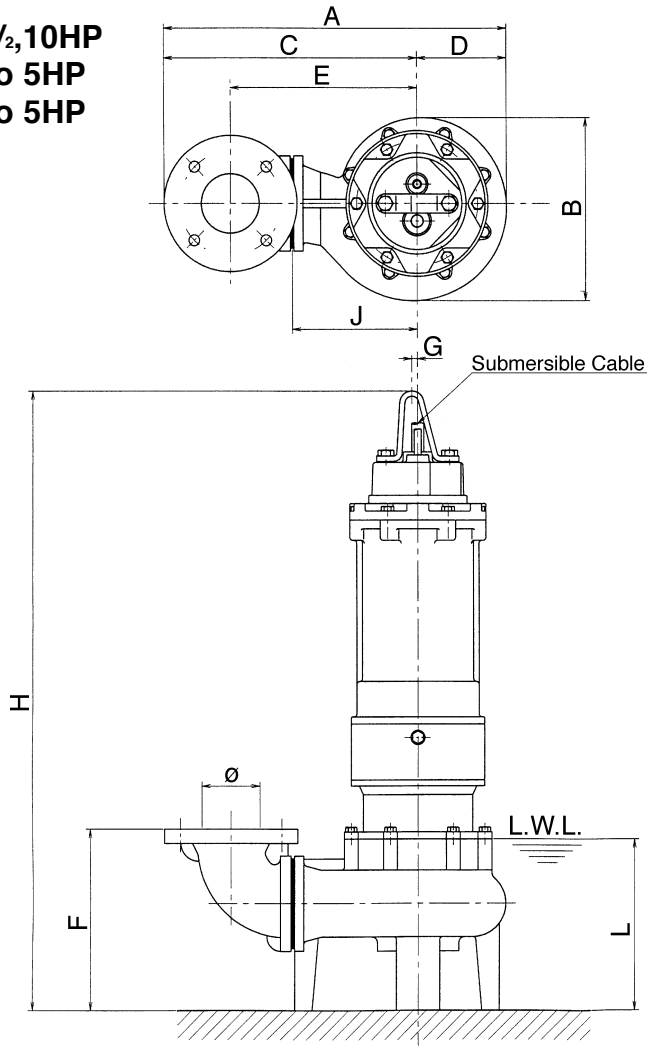

**Flange (ANSI 125 PSI F.F)**

| inch |                               |                               |                                |   |                               |
|------|-------------------------------|-------------------------------|--------------------------------|---|-------------------------------|
| ø    | e                             | f                             | t                              | n | h                             |
| 2    | 4 <sup>3</sup> / <sub>4</sub> | 6                             | 5 <sup>5</sup> / <sub>8</sub>  | 4 | 3 <sup>3</sup> / <sub>4</sub> |
| 3    | 6                             | 7 <sup>1</sup> / <sub>2</sub> | 3 <sup>3</sup> / <sub>4</sub>  | 4 | 3 <sup>3</sup> / <sub>4</sub> |
| 4    | 7 <sup>1</sup> / <sub>2</sub> | 9                             | 1 <sup>5</sup> / <sub>16</sub> | 8 | 3 <sup>3</sup> / <sub>4</sub> |

| mm  |     |     |    |   |    |
|-----|-----|-----|----|---|----|
| ø   | e   | f   | t  | n | h  |
| 50  | 121 | 152 | 16 | 4 | 19 |
| 80  | 152 | 191 | 19 | 4 | 19 |
| 100 | 191 | 229 | 24 | 8 | 19 |

**Dimensions: inch**

| PHASE      | SIZE ø | MODEL       | OUTPUT                         |                                | PUMP & MOTOR                     |                                 |                                  |                                 |                                  |                                 |                                |                                 |                                |                                | WEIGHT Lb |
|------------|--------|-------------|--------------------------------|--------------------------------|----------------------------------|---------------------------------|----------------------------------|---------------------------------|----------------------------------|---------------------------------|--------------------------------|---------------------------------|--------------------------------|--------------------------------|-----------|
|            |        |             | kW                             | HP                             | A                                | B                               | C                                | D                               | E                                | F                               | G                              | H                               | J                              | L                              |           |
| THREE      | 2/3    | 80DVFU61.5  | 1.5                            | 2                              | 17 <sup>11</sup> / <sub>16</sub> | 9 <sup>3</sup> / <sub>8</sub>   | 13 <sup>1</sup> / <sub>16</sub>  | 4 <sup>11</sup> / <sub>16</sub> | 9 <sup>1</sup> / <sub>4</sub>    | 8 <sup>13</sup> / <sub>16</sub> | 5 <sup>5</sup> / <sub>16</sub> | 29 <sup>7</sup> / <sub>16</sub> | 6 <sup>5</sup> / <sub>16</sub> | 8 <sup>1</sup> / <sub>16</sub> | 130       |
|            |        | 80DVCFU62.2 | 2.2                            | 3                              | 17 <sup>11</sup> / <sub>16</sub> | 9 <sup>3</sup> / <sub>8</sub>   | 13 <sup>1</sup> / <sub>16</sub>  | 4 <sup>11</sup> / <sub>16</sub> | 9 <sup>1</sup> / <sub>4</sub>    | 8 <sup>13</sup> / <sub>16</sub> | 5 <sup>5</sup> / <sub>16</sub> | 30 <sup>7</sup> / <sub>16</sub> | 6 <sup>5</sup> / <sub>16</sub> | 8 <sup>1</sup> / <sub>4</sub>  | 159       |
|            |        | 80DVCFU63.7 | 3.7                            | 5                              | 17 <sup>11</sup> / <sub>16</sub> | 9 <sup>3</sup> / <sub>8</sub>   | 13 <sup>1</sup> / <sub>16</sub>  | 4 <sup>11</sup> / <sub>16</sub> | 9 <sup>1</sup> / <sub>4</sub>    | 8 <sup>13</sup> / <sub>16</sub> | 5 <sup>5</sup> / <sub>16</sub> | 32                              | 6 <sup>5</sup> / <sub>16</sub> | 8 <sup>1</sup> / <sub>4</sub>  | 172       |
|            | 3/4    | 80DVBFU62.2 | 2.2                            | 3                              | 18 <sup>9</sup> / <sub>16</sub>  | 9 <sup>15</sup> / <sub>16</sub> | 13 <sup>5</sup> / <sub>8</sub>   | 4 <sup>15</sup> / <sub>16</sub> | 9 <sup>13</sup> / <sub>16</sub>  | 10                              | 5 <sup>5</sup> / <sub>16</sub> | 32 <sup>5</sup> / <sub>16</sub> | 6 <sup>7</sup> / <sub>8</sub>  | 10 <sup>1</sup> / <sub>4</sub> | 176       |
|            |        | 80DVBFU63.7 | 3.7                            | 5                              | 18 <sup>9</sup> / <sub>16</sub>  | 9 <sup>15</sup> / <sub>16</sub> | 13 <sup>5</sup> / <sub>8</sub>   | 4 <sup>15</sup> / <sub>16</sub> | 9 <sup>13</sup> / <sub>16</sub>  | 10                              | 5 <sup>5</sup> / <sub>16</sub> | 33 <sup>7</sup> / <sub>8</sub>  | 6 <sup>7</sup> / <sub>8</sub>  | 10 <sup>1</sup> / <sub>4</sub> | 176       |
|            |        | 80DVFU65.5  | 5.5                            | 7 <sup>1</sup> / <sub>2</sub>  | 20 <sup>1</sup> / <sub>4</sub>   | 11 <sup>1</sup> / <sub>4</sub>  | 14 <sup>5</sup> / <sub>8</sub>   | 5 <sup>5</sup> / <sub>8</sub>   | 10 <sup>13</sup> / <sub>16</sub> | 10                              | 3 <sup>3</sup> / <sub>8</sub>  | 39 <sup>1</sup> / <sub>8</sub>  | 7 <sup>1</sup> / <sub>8</sub>  | 13                             | 262       |
| 80DVFU67.5 | 7.5    | 10          | 20 <sup>1</sup> / <sub>4</sub> | 11 <sup>1</sup> / <sub>4</sub> | 14 <sup>5</sup> / <sub>8</sub>   | 5 <sup>5</sup> / <sub>8</sub>   | 10 <sup>13</sup> / <sub>16</sub> | 10                              | 3 <sup>3</sup> / <sub>8</sub>    | 39 <sup>1</sup> / <sub>8</sub>  | 7 <sup>1</sup> / <sub>8</sub>  | 13                              | 291                            |                                |           |

**Dimensions: mm**

| PHASE      | SIZE ø | MODEL       | OUTPUT |                               | PUMP & MOTOR |     |     |     |     |     |     |     |     |     | WEIGHT kg |
|------------|--------|-------------|--------|-------------------------------|--------------|-----|-----|-----|-----|-----|-----|-----|-----|-----|-----------|
|            |        |             | kW     | HP                            | A            | B   | C   | D   | E   | F   | G   | H   | J   | L   |           |
| THREE      | 50/80  | 80DVFU61.5  | 1.5    | 2                             | 450          | 238 | 331 | 119 | 235 | 224 | 8   | 747 | 160 | 205 | 59        |
|            |        | 80DVCFU62.2 | 2.2    | 3                             | 450          | 238 | 331 | 119 | 235 | 224 | 8   | 773 | 160 | 210 | 72        |
|            |        | 80DVCFU63.7 | 3.7    | 5                             | 450          | 238 | 331 | 119 | 235 | 224 | 8   | 813 | 160 | 210 | 78        |
|            | 80/100 | 80DVBFU62.2 | 2.2    | 3                             | 471          | 252 | 346 | 125 | 250 | 254 | 8   | 820 | 175 | 260 | 80        |
|            |        | 80DVBFU63.7 | 3.7    | 5                             | 471          | 252 | 346 | 125 | 250 | 254 | 8   | 860 | 175 | 260 | 80        |
|            |        | 80DVFU65.5  | 5.5    | 7 <sup>1</sup> / <sub>2</sub> | 514          | 285 | 371 | 143 | 275 | 254 | 10  | 994 | 200 | 330 | 119       |
| 80DVFU67.5 | 7.5    | 10          | 514    | 285                           | 371          | 143 | 275 | 254 | 10  | 994 | 200 | 330 | 132 |     |           |

**\*Note:** All dimensions are based on 3" discharge.

**Dimensions**

Project: \_\_\_\_\_ Model: \_\_\_\_\_ Chk'd: \_\_\_\_\_ Date: \_\_\_\_\_

**Model DVFU**  
**80DVBFU, 15HP**  
**80DVCFU, 15 to 30HP**

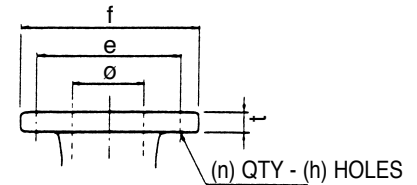
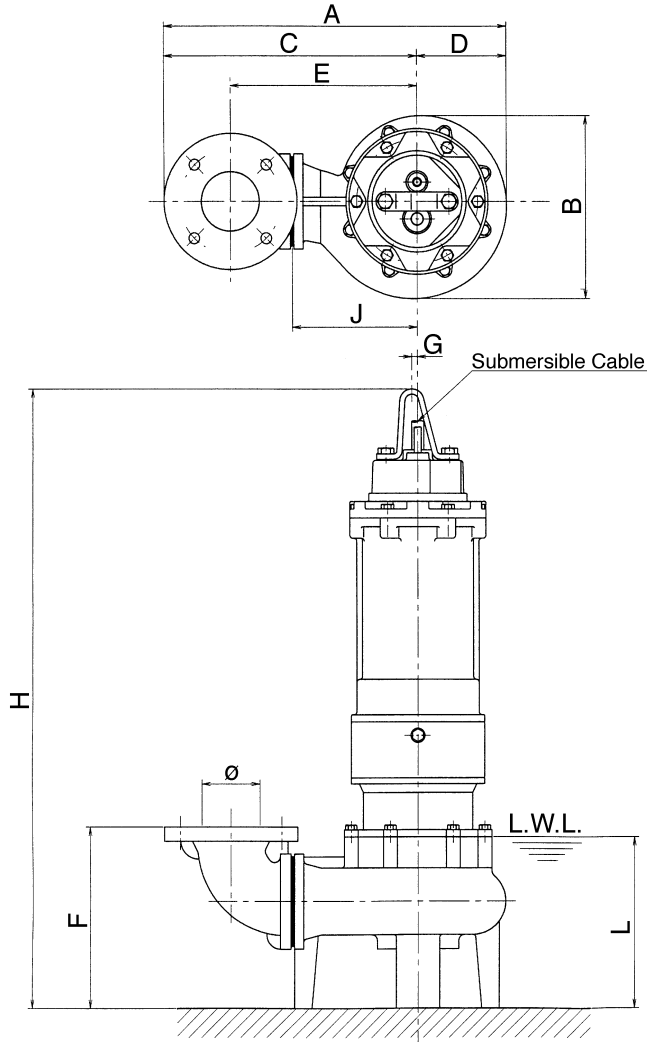

**Flange (ANSI 125 PSI F.F)**

| inch |       |       |       |   |     |
|------|-------|-------|-------|---|-----|
| ø    | e     | f     | t     | n | h   |
| 3    | 6     | 7 1/2 | 3/4   | 4 | 3/4 |
| 4    | 7 1/2 | 9     | 15/16 | 8 | 3/4 |

| mm  |     |     |    |   |    |
|-----|-----|-----|----|---|----|
| ø   | e   | f   | t  | n | h  |
| 80  | 152 | 191 | 19 | 4 | 19 |
| 100 | 191 | 229 | 24 | 8 | 19 |

**Dimensions: inch**

| PHASE | SIZE ø | MODEL      | OUTPUT |    | PUMP & MOTOR |         |         |       |          |    |      |          |        |        | WEIGHT Lb |
|-------|--------|------------|--------|----|--------------|---------|---------|-------|----------|----|------|----------|--------|--------|-----------|
|       |        |            | kW     | HP | A            | B       | C       | D     | E        | F  | G    | H        | J      | L      |           |
| THREE | 3/4    | 80DVBFU611 | 11     | 15 | 20 1/4       | 11 1/4  | 14 5/8  | 5 5/8 | 10 13/16 | 10 | 5/16 | 42 13/16 | 7 7/8  | 13     | 390       |
|       |        | 80DVCFU611 | 11     | 15 | 22 15/16     | 13 7/16 | 16 3/16 | 6 3/4 | 12 3/8   | 10 | 5/16 | 42 13/16 | 9 7/16 | 13     | 406       |
|       |        | 80DVCFU615 | 15     | 20 | 22 15/16     | 13 7/16 | 16 3/16 | 6 3/4 | 12 3/8   | 10 | 5/16 | 45 3/8   | 9 7/16 | 13 3/4 | 503       |
|       |        | 80DVCFU618 | 18     | 25 | 22 15/16     | 13 7/16 | 16 3/16 | 6 3/4 | 12 3/8   | 10 | 5/16 | 46 15/16 | 9 7/16 | 13 3/4 | 578       |
|       |        | 80DVCFU622 | 22     | 30 | 22 15/16     | 13 7/16 | 16 3/16 | 6 3/4 | 12 3/8   | 10 | 5/16 | 46 15/16 | 9 7/16 | 13 3/4 | 633       |

**Dimensions: mm**

| PHASE | SIZE ø | MODEL      | OUTPUT |    | PUMP & MOTOR |     |     |     |     |     |   |      |     |     | WEIGHT kg |
|-------|--------|------------|--------|----|--------------|-----|-----|-----|-----|-----|---|------|-----|-----|-----------|
|       |        |            | kW     | HP | A            | B   | C   | D   | E   | F   | G | H    | J   | L   |           |
| THREE | 80/100 | 80DVBFU611 | 11     | 15 | 514          | 285 | 371 | 143 | 275 | 254 | 8 | 1087 | 200 | 330 | 177       |
|       |        | 80DVCFU611 | 11     | 15 | 582          | 342 | 411 | 171 | 315 | 254 | 8 | 1087 | 240 | 330 | 184       |
|       |        | 80DVCFU615 | 15     | 20 | 582          | 342 | 411 | 171 | 315 | 254 | 8 | 1152 | 240 | 350 | 228       |
|       |        | 80DVCFU618 | 18     | 25 | 582          | 342 | 411 | 171 | 315 | 254 | 8 | 1192 | 240 | 350 | 262       |
|       |        | 80DVCFU622 | 22     | 30 | 582          | 342 | 411 | 171 | 315 | 254 | 8 | 1192 | 240 | 350 | 287       |

**\*Note:** All dimensions are based on 3" discharge.

Dimensions

Project: \_\_\_\_\_ Model: \_\_\_\_\_ Chk'd: \_\_\_\_\_ Date: \_\_\_\_\_

**Model DVFU**  
**100DVFU, 5 to 10HP**  
**100DVBFU, 15HP**

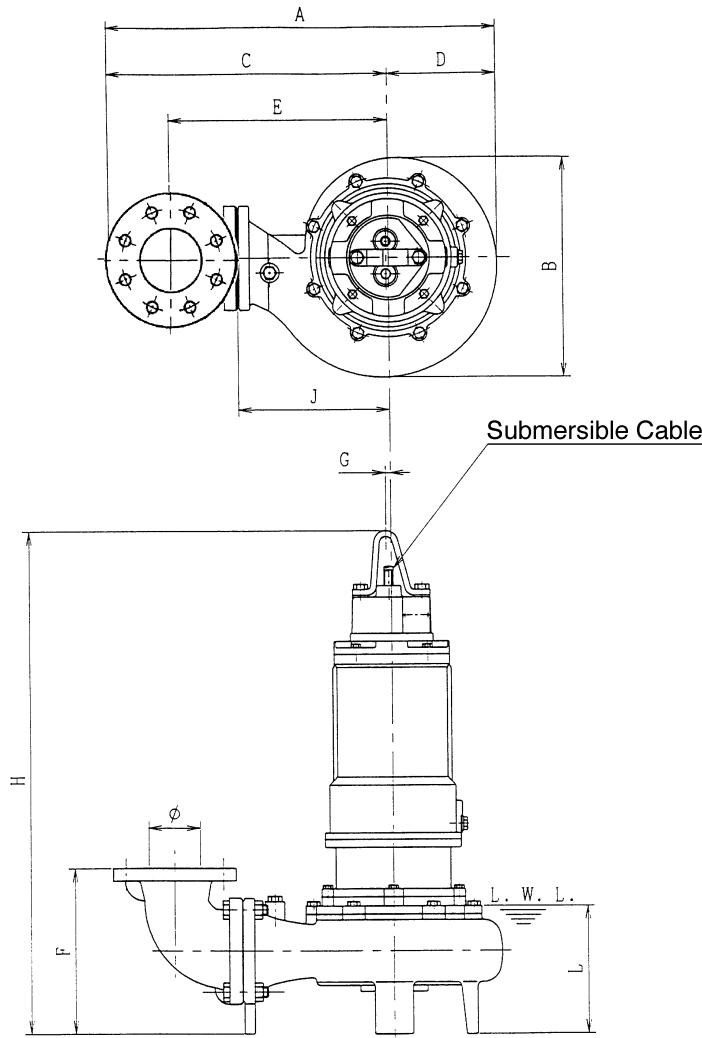

**Flange (ANSI 125 PSI F.F)**

| inch |       |       |       |   |     |
|------|-------|-------|-------|---|-----|
| ø    | e     | f     | t     | n | h   |
| 3    | 6     | 7 1/2 | 3/4   | 4 | 3/4 |
| 4    | 7 1/2 | 9     | 15/16 | 8 | 3/4 |

| mm  |     |     |    |   |    |
|-----|-----|-----|----|---|----|
| ø   | e   | f   | t  | n | h  |
| 80  | 152 | 191 | 19 | 4 | 19 |
| 100 | 191 | 229 | 24 | 8 | 19 |

**Dimensions: inch**

| PHASE | SIZE<br>ø | MODEL       | OUTPUT |       | PUMP & MOTOR |        |        |        |        |    |      |         |        |        | WEIGHT<br>Lb |
|-------|-----------|-------------|--------|-------|--------------|--------|--------|--------|--------|----|------|---------|--------|--------|--------------|
|       |           |             | kW     | HP    | A            | B      | C      | D      | E      | F  | G    | H       | J      | L      |              |
| THREE | 3/4       | 100DVFU63.7 | 3.7    | 5     | 23 3/16      | 12 1/8 | 17 1/8 | 6 1/16 | 12 5/8 | 12 | 5/16 | 36 1/16 | 8 7/16 | 12 3/8 | 209          |
|       |           | 100DVFU65.5 | 5.5    | 7 1/2 | 23 3/16      | 12 1/8 | 17 1/8 | 6 1/16 | 12 5/8 | 12 | 3/8  | 41 3/8  | 8 7/16 | 15 1/4 | 317          |
|       |           | 100DVFU67.5 | 7.5    | 10    | 23 3/16      | 12 1/8 | 17 1/8 | 6 1/16 | 12 5/8 | 12 | 3/8  | 41 3/8  | 8 7/16 | 15 1/4 | 346          |
|       |           | 100DVBFU611 | 11     | 15    | 23 3/16      | 12 1/8 | 17 1/8 | 6 1/16 | 12 5/8 | 12 | 5/16 | 45 1/16 | 8 7/16 | 15 1/4 | 452          |

**Dimensions: mm**

| PHASE | SIZE   | MODEL       | OUTPUT |       | PUMP & MOTOR |     |     |     |     |     |    |      |     |     | WEIGHT<br>kg |
|-------|--------|-------------|--------|-------|--------------|-----|-----|-----|-----|-----|----|------|-----|-----|--------------|
|       |        |             | kW     | HP    | A            | B   | C   | D   | E   | F   | G  | H    | J   | L   |              |
| THREE | 80/100 | 100DVFU63.7 | 3.7    | 5     | 589          | 308 | 435 | 154 | 320 | 305 | 8  | 916  | 215 | 315 | 95           |
|       |        | 100DVFU65.5 | 5.5    | 7 1/2 | 589          | 308 | 435 | 154 | 320 | 305 | 10 | 1051 | 215 | 388 | 144          |
|       |        | 100DVFU67.5 | 7.5    | 10    | 589          | 308 | 435 | 154 | 320 | 305 | 10 | 1051 | 215 | 388 | 157          |
|       |        | 100DVBFU611 | 11     | 15    | 589          | 308 | 435 | 154 | 320 | 305 | 8  | 1144 | 215 | 388 | 205          |

**Dimensions**

Project: \_\_\_\_\_ Model: \_\_\_\_\_ Chk'd: \_\_\_\_\_ Date: \_\_\_\_\_

**Model DVFU**  
**100DVCFU, 15 to 20HP**  
**100DVDFU, 15 to 30HP**

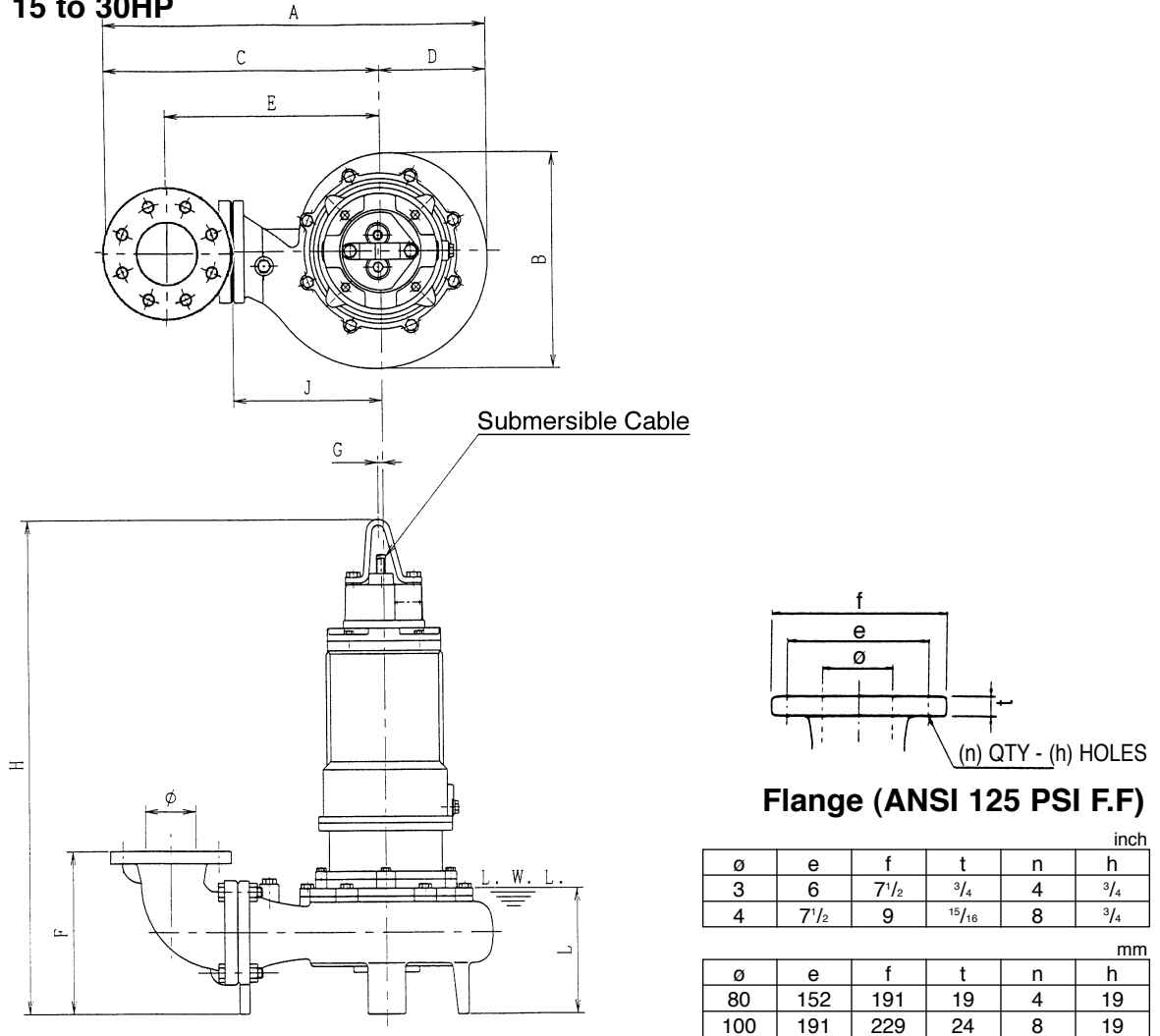

**Dimensions: inch**

| PHASE | SIZE<br>∅ | MODEL       | OUTPUT |    | PUMP & MOTOR       |                   |                   |                    |                   |    |      |                     |                    |                     | WEIGHT<br>Lb |
|-------|-----------|-------------|--------|----|--------------------|-------------------|-------------------|--------------------|-------------------|----|------|---------------------|--------------------|---------------------|--------------|
|       |           |             | kW     | HP | A                  | B                 | C                 | D                  | E                 | F  | G    | H                   | J                  | L                   |              |
| THREE | 3/4       | 100DVCFU611 | 11     | 15 | 23 <sup>3/16</sup> | 12 <sup>1/8</sup> | 17 <sup>1/8</sup> | 6 <sup>1/16</sup>  | 12 <sup>5/8</sup> | 12 | 5/16 | 45 <sup>1/16</sup>  | 8 <sup>7/16</sup>  | 15 <sup>1/4</sup>   | 452          |
|       |           | 100DVCFU615 | 15     | 20 | 23 <sup>3/16</sup> | 12 <sup>1/8</sup> | 17 <sup>1/8</sup> | 6 <sup>1/16</sup>  | 12 <sup>5/8</sup> | 12 | 5/16 | 47 <sup>5/8</sup>   | 8 <sup>7/16</sup>  | 15 <sup>15/16</sup> | 547          |
|       |           | 100DVDFU611 | 11     | 15 | 25 <sup>7/16</sup> | 13 <sup>7/8</sup> | 18 <sup>1/2</sup> | 6 <sup>15/16</sup> | 14                | 12 | 5/16 | 44 <sup>15/16</sup> | 9 <sup>13/16</sup> | 15 <sup>1/4</sup>   | 445          |
|       |           | 100DVDFU615 | 15     | 20 | 25 <sup>7/16</sup> | 13 <sup>7/8</sup> | 18 <sup>1/2</sup> | 6 <sup>15/16</sup> | 14                | 12 | 5/16 | 47 <sup>1/2</sup>   | 9 <sup>13/16</sup> | 15 <sup>15/16</sup> | 547          |
|       |           | 100DVDFU618 | 18     | 25 | 25 <sup>7/16</sup> | 13 <sup>7/8</sup> | 18 <sup>1/2</sup> | 6 <sup>15/16</sup> | 14                | 12 | 5/16 | 49 <sup>1/8</sup>   | 9 <sup>13/16</sup> | 15 <sup>15/16</sup> | 602          |
|       |           | 100DVDFU622 | 22     | 30 | 25 <sup>7/16</sup> | 13 <sup>7/8</sup> | 18 <sup>1/2</sup> | 6 <sup>15/16</sup> | 14                | 12 | 5/16 | 49 <sup>1/8</sup>   | 9 <sup>13/16</sup> | 15 <sup>15/16</sup> | 668          |

**Dimensions: mm**

| PHASE | SIZE<br>∅ | MODEL       | OUTPUT |    | PUMP & MOTOR |     |     |     |     |     |   |      |     |     | WEIGHT<br>kg |
|-------|-----------|-------------|--------|----|--------------|-----|-----|-----|-----|-----|---|------|-----|-----|--------------|
|       |           |             | kW     | HP | A            | B   | C   | D   | E   | F   | G | H    | J   | L   |              |
| THREE | 80/100    | 100DVCFU611 | 11     | 15 | 589          | 308 | 435 | 154 | 320 | 305 | 8 | 1144 | 215 | 388 | 205          |
|       |           | 100DVCFU615 | 15     | 20 | 589          | 308 | 435 | 154 | 320 | 305 | 8 | 1209 | 215 | 405 | 248          |
|       |           | 100DVDFU611 | 11     | 15 | 646          | 352 | 470 | 176 | 355 | 305 | 8 | 1142 | 250 | 388 | 202          |
|       |           | 100DVDFU615 | 15     | 20 | 646          | 352 | 470 | 176 | 355 | 305 | 8 | 1207 | 250 | 405 | 248          |
|       |           | 100DVDFU618 | 18     | 25 | 646          | 352 | 470 | 176 | 355 | 305 | 8 | 1247 | 250 | 405 | 273          |
|       |           | 100DVDFU622 | 22     | 30 | 646          | 352 | 470 | 176 | 355 | 305 | 8 | 1247 | 250 | 405 | 303          |

**Dimensions**

Project: \_\_\_\_\_ Model: \_\_\_\_\_ Chk'd: \_\_\_\_\_ Date: \_\_\_\_\_

**Model DVFU**  
**150DVBFU, 15 to 30HP**  
**150DVCFU, 25 to 30HP**

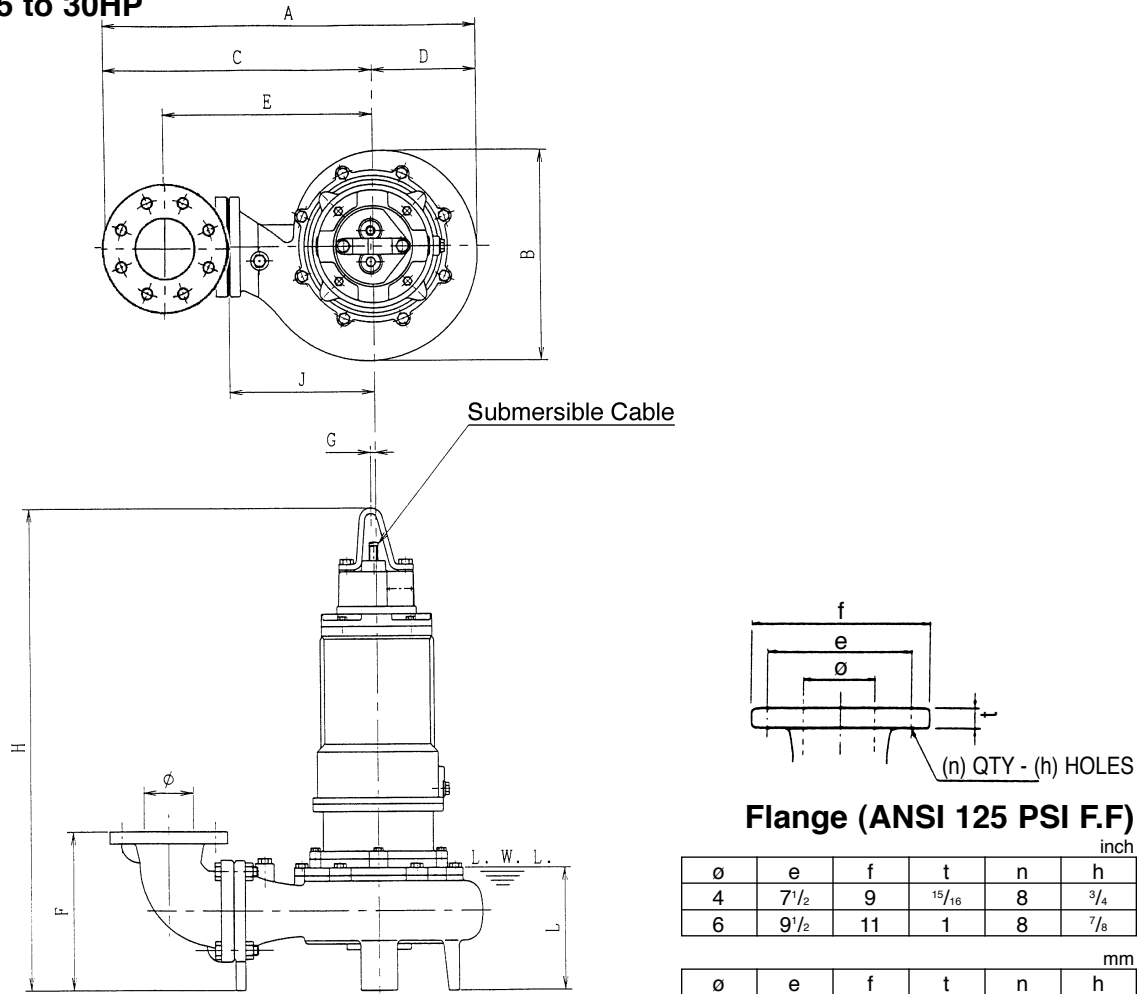

**Dimensions: inch**

| PHASE | SIZE<br>ø | MODEL       | OUTPUT |    | PUMP & MOTOR                   |                                 |                                  |                                 |                                 |                                  |                                |                                  |                                |                                | WEIGHT<br>Lb |
|-------|-----------|-------------|--------|----|--------------------------------|---------------------------------|----------------------------------|---------------------------------|---------------------------------|----------------------------------|--------------------------------|----------------------------------|--------------------------------|--------------------------------|--------------|
|       |           |             | kW     | HP | A                              | B                               | C                                | D                               | E                               | F                                | G                              | H                                | J                              | L                              |              |
| THREE | 4/6       | 150DVBFU611 | 11     | 15 | 27 <sup>3</sup> / <sub>8</sub> | 13 <sup>1</sup> / <sub>16</sub> | 20 <sup>11</sup> / <sub>16</sub> | 6 <sup>11</sup> / <sub>16</sub> | 15 <sup>9</sup> / <sub>16</sub> | 15 <sup>13</sup> / <sub>16</sub> | 5 <sup>5</sup> / <sub>16</sub> | 47 <sup>15</sup> / <sub>16</sub> | 9 <sup>1</sup> / <sub>4</sub>  | 18 <sup>7</sup> / <sub>8</sub> | 514          |
|       |           | 150DVBFU615 | 15     | 20 | 27 <sup>3</sup> / <sub>8</sub> | 13 <sup>1</sup> / <sub>16</sub> | 20 <sup>11</sup> / <sub>16</sub> | 6 <sup>11</sup> / <sub>16</sub> | 15 <sup>9</sup> / <sub>16</sub> | 15 <sup>13</sup> / <sub>16</sub> | 5 <sup>5</sup> / <sub>16</sub> | 50 <sup>1</sup> / <sub>2</sub>   | 9 <sup>1</sup> / <sub>4</sub>  | 18 <sup>7</sup> / <sub>8</sub> | 608          |
|       |           | 150DVBFU618 | 18     | 25 | 27 <sup>3</sup> / <sub>8</sub> | 13 <sup>1</sup> / <sub>16</sub> | 20 <sup>11</sup> / <sub>16</sub> | 6 <sup>11</sup> / <sub>16</sub> | 15 <sup>9</sup> / <sub>16</sub> | 15 <sup>13</sup> / <sub>16</sub> | 5 <sup>5</sup> / <sub>16</sub> | 52 <sup>1</sup> / <sub>16</sub>  | 9 <sup>1</sup> / <sub>4</sub>  | 18 <sup>7</sup> / <sub>8</sub> | 683          |
|       |           | 150DVBFU622 | 22     | 30 | 27 <sup>3</sup> / <sub>8</sub> | 13 <sup>1</sup> / <sub>16</sub> | 20 <sup>11</sup> / <sub>16</sub> | 6 <sup>11</sup> / <sub>16</sub> | 15 <sup>9</sup> / <sub>16</sub> | 15 <sup>13</sup> / <sub>16</sub> | 5 <sup>5</sup> / <sub>16</sub> | 52 <sup>1</sup> / <sub>16</sub>  | 9 <sup>1</sup> / <sub>4</sub>  | 18 <sup>7</sup> / <sub>8</sub> | 739          |
|       |           | 150DVCFU618 | 18     | 25 | 29 <sup>5</sup> / <sub>8</sub> | 15 <sup>1</sup> / <sub>8</sub>  | 22 <sup>1</sup> / <sub>16</sub>  | 7 <sup>9</sup> / <sub>16</sub>  | 16 <sup>9</sup> / <sub>16</sub> | 15 <sup>13</sup> / <sub>16</sub> | 5 <sup>5</sup> / <sub>16</sub> | 51 <sup>15</sup> / <sub>16</sub> | 10 <sup>5</sup> / <sub>8</sub> | 18 <sup>7</sup> / <sub>8</sub> | 708          |
|       |           | 150DVCFU622 | 22     | 30 | 29 <sup>5</sup> / <sub>8</sub> | 15 <sup>1</sup> / <sub>8</sub>  | 22 <sup>1</sup> / <sub>16</sub>  | 7 <sup>9</sup> / <sub>16</sub>  | 16 <sup>9</sup> / <sub>16</sub> | 15 <sup>13</sup> / <sub>16</sub> | 5 <sup>5</sup> / <sub>16</sub> | 51 <sup>15</sup> / <sub>16</sub> | 10 <sup>5</sup> / <sub>8</sub> | 18 <sup>7</sup> / <sub>8</sub> | 763          |

**Dimensions: mm**

| PHASE | SIZE<br>ø | MODEL       | OUTPUT |    | PUMP & MOTOR |     |     |     |     |     |   |      |     |     | WEIGHT<br>kg |
|-------|-----------|-------------|--------|----|--------------|-----|-----|-----|-----|-----|---|------|-----|-----|--------------|
|       |           |             | kW     | HP | A            | B   | C   | D   | E   | F   | G | H    | J   | L   |              |
| THREE | 100/150   | 150DVBFU611 | 11     | 15 | 695          | 332 | 525 | 170 | 385 | 401 | 8 | 1218 | 235 | 480 | 233          |
|       |           | 150DVBFU615 | 15     | 20 | 695          | 332 | 525 | 170 | 385 | 401 | 8 | 1283 | 235 | 480 | 276          |
|       |           | 150DVBFU618 | 18     | 25 | 695          | 332 | 525 | 170 | 385 | 401 | 8 | 1323 | 235 | 480 | 310          |
|       |           | 150DVBFU622 | 22     | 30 | 695          | 332 | 525 | 170 | 385 | 401 | 8 | 1323 | 235 | 480 | 335          |
|       |           | 150DVCFU618 | 18     | 25 | 752          | 384 | 560 | 192 | 420 | 401 | 8 | 1320 | 270 | 480 | 321          |
|       |           | 150DVCFU622 | 22     | 30 | 752          | 384 | 560 | 192 | 420 | 401 | 8 | 1320 | 270 | 480 | 346          |

**\*Note:** All dimensions are based on 6" discharge.



**Dimensions**

Project: \_\_\_\_\_ Model: \_\_\_\_\_ Chk'd: \_\_\_\_\_ Date: \_\_\_\_\_

**Model DVFU with Quick Discharge Connector  
50DVFU, 2 to 3HP**

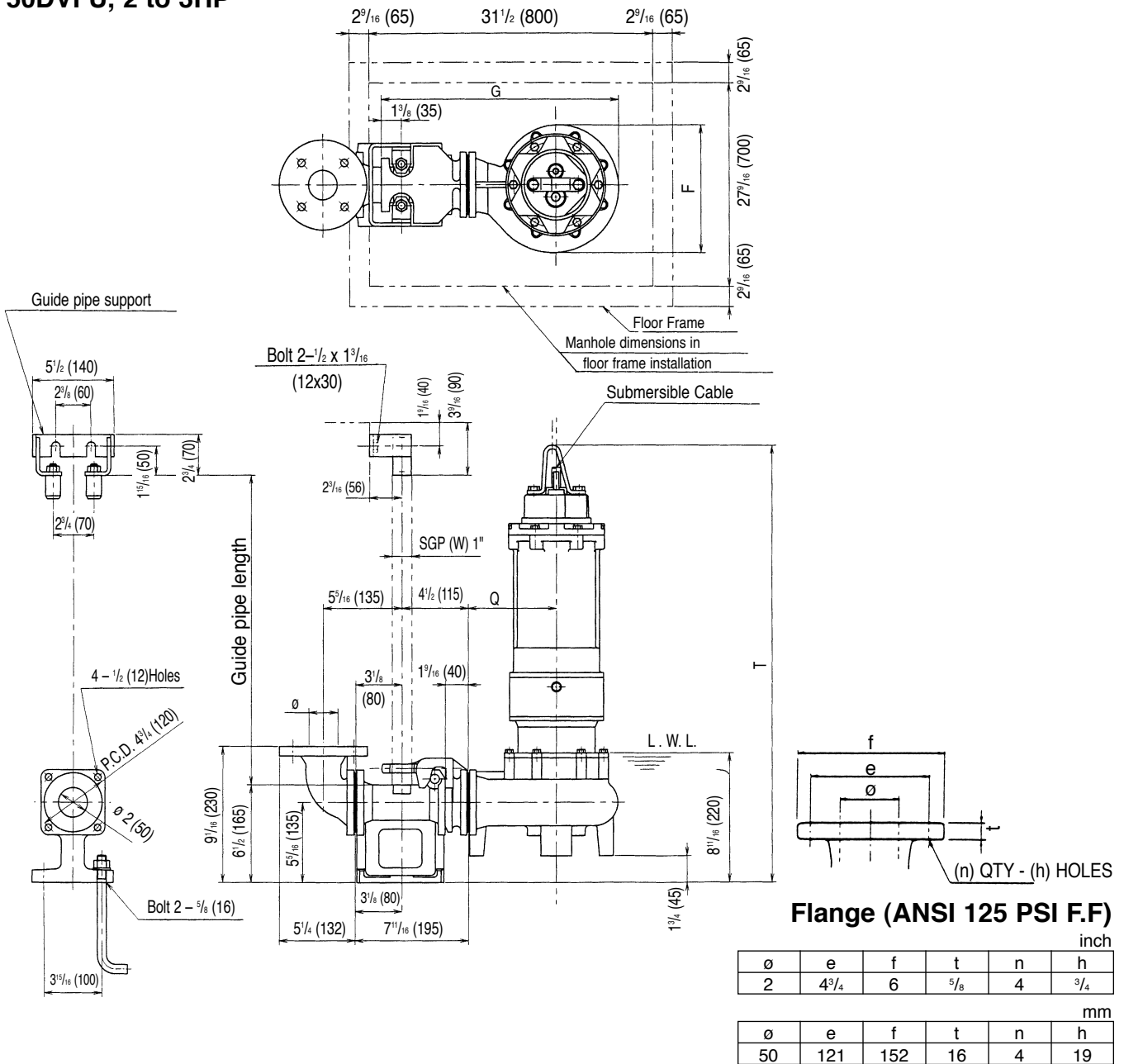

**Dimensions: inch**

| PHASE | SIZE<br>ø | MODEL      | OUTPUT |    | Q.D.C.<br>MODEL | PUMP & MOTOR                  |                                |                               |                                  | WEIGHT Lb |        |
|-------|-----------|------------|--------|----|-----------------|-------------------------------|--------------------------------|-------------------------------|----------------------------------|-----------|--------|
|       |           |            | kW     | HP |                 | F                             | G                              | Q                             | T                                | PUMP      | Q.D.C. |
| THREE | 2         | 50DVFU61.5 | 1.5    | 2  | LM50            | 9 <sup>3</sup> / <sub>8</sub> | 16 <sup>1</sup> / <sub>4</sub> | 5 <sup>7</sup> / <sub>8</sub> | 29 <sup>3</sup> / <sub>4</sub>   | 121       | 24     |
|       |           | 50DVFU62.2 | 2.2    | 3  | LM50            | 9 <sup>3</sup> / <sub>8</sub> | 15 <sup>1</sup> / <sub>8</sub> | 5 <sup>7</sup> / <sub>8</sub> | 30 <sup>13</sup> / <sub>16</sub> | 150       | 24     |

**Dimensions: mm**

| PHASE | SIZE<br>ø | MODEL      | OUTPUT |    | Q.D.C.<br>MODEL | PUMP & MOTOR |     |     |     | WEIGHT kg |        |
|-------|-----------|------------|--------|----|-----------------|--------------|-----|-----|-----|-----------|--------|
|       |           |            | kW     | HP |                 | F            | G   | Q   | T   | PUMP      | Q.D.C. |
| THREE | 50        | 50DVFU61.5 | 1.5    | 2  | LM50            | 238          | 413 | 150 | 756 | 55        | 11     |
|       |           | 50DVFU62.2 | 2.2    | 3  | LM50            | 238          | 384 | 150 | 782 | 68        | 11     |

**Dimensions**

Project: \_\_\_\_\_ Model: \_\_\_\_\_ Chk'd: \_\_\_\_\_ Date: \_\_\_\_\_

**Model DVFU with Quick Discharge Connector**

**80DVFU, 2HP**  
**80DVCFU, 3 to 5HP**

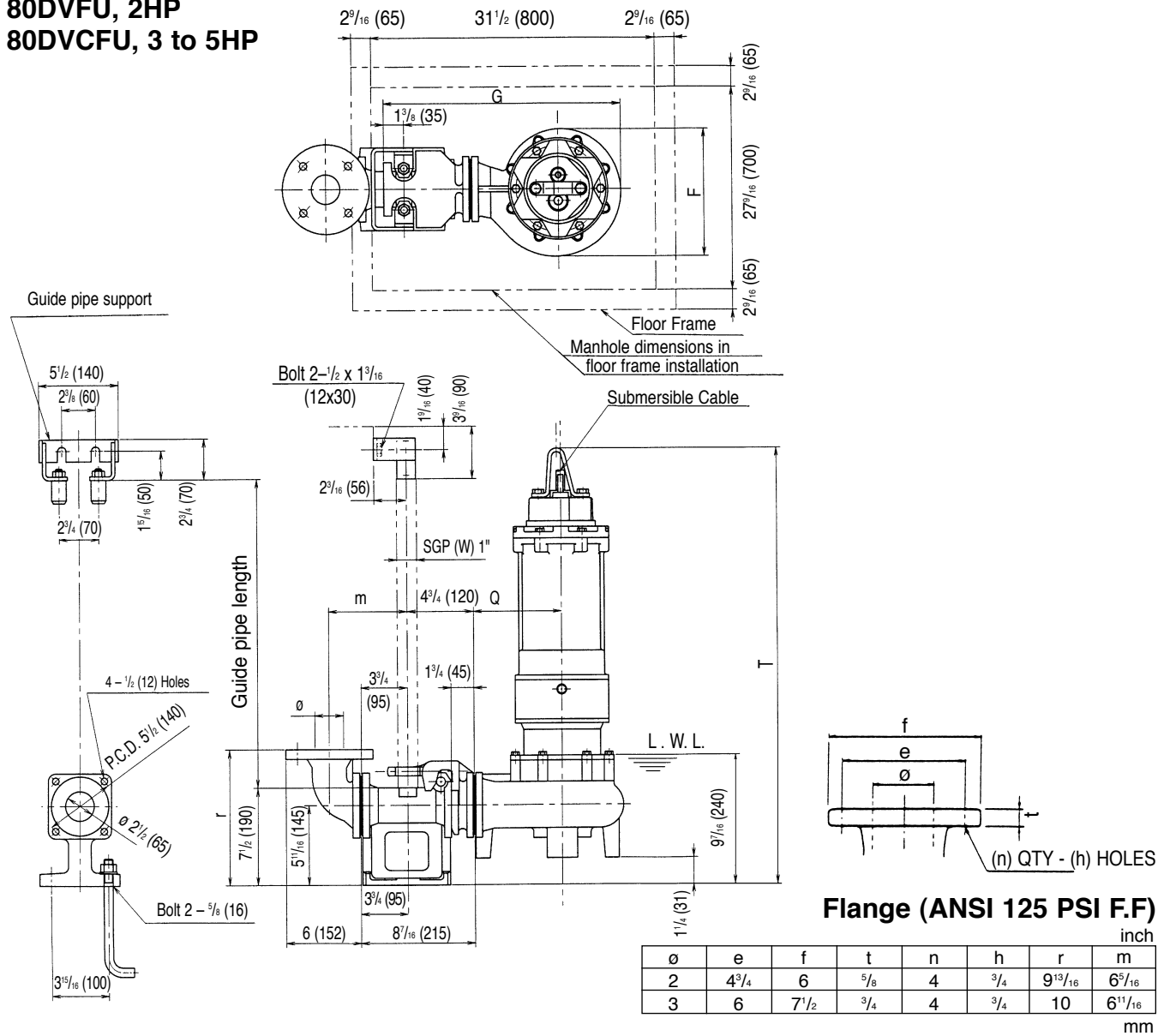

**Flange (ANSI 125 PSI F.F)**

| inch |                               |                               |                               |   |                               |                                |                                 |
|------|-------------------------------|-------------------------------|-------------------------------|---|-------------------------------|--------------------------------|---------------------------------|
| ø    | e                             | f                             | t                             | n | h                             | r                              | m                               |
| 2    | 4 <sup>3</sup> / <sub>4</sub> | 6                             | 5 <sup>5</sup> / <sub>8</sub> | 4 | 3 <sup>3</sup> / <sub>4</sub> | 9 <sup>9</sup> / <sub>16</sub> | 6 <sup>5</sup> / <sub>16</sub>  |
| 3    | 6                             | 7 <sup>1</sup> / <sub>2</sub> | 3 <sup>3</sup> / <sub>4</sub> | 4 | 3 <sup>3</sup> / <sub>4</sub> | 10                             | 6 <sup>11</sup> / <sub>16</sub> |
| mm   |                               |                               |                               |   |                               |                                |                                 |
| ø    | e                             | f                             | t                             | n | h                             | r                              | m                               |
| 50   | 121                           | 152                           | 16                            | 4 | 19                            | 250                            | 161                             |
| 80   | 152                           | 191                           | 19                            | 4 | 19                            | 254                            | 170                             |

**Dimensions: inch**

| PHASE | SIZE ø | MODEL       | OUTPUT |    | Q.D.C. MODEL | PUMP & MOTOR                  |                                |                                |                                  | WEIGHT Lb |        |
|-------|--------|-------------|--------|----|--------------|-------------------------------|--------------------------------|--------------------------------|----------------------------------|-----------|--------|
|       |        |             | kW     | HP |              | F                             | G                              | Q                              | T                                | PUMP      | Q.D.C. |
| THREE | 2/3    | 80DVFU61.5  | 1.5    | 2  | LM65         | 9 <sup>3</sup> / <sub>8</sub> | 16 <sup>7</sup> / <sub>8</sub> | 6 <sup>5</sup> / <sub>16</sub> | 30 <sup>3</sup> / <sub>8</sub>   | 130       | 31     |
|       |        | 80DVCFU62.2 | 2.2    | 3  | LM65         | 9 <sup>3</sup> / <sub>8</sub> | 16 <sup>7</sup> / <sub>8</sub> | 6 <sup>5</sup> / <sub>16</sub> | 31 <sup>11</sup> / <sub>16</sub> | 159       | 31     |
|       |        | 80DVCFU63.7 | 3.7    | 5  | LM65         | 9 <sup>3</sup> / <sub>8</sub> | 19                             | 6 <sup>5</sup> / <sub>16</sub> | 33 <sup>3</sup> / <sub>4</sub>   | 172       | 31     |

**Dimensions: mm**

| PHASE | SIZE ø | MODEL       | OUTPUT |    | Q.D.C. MODEL | PUMP & MOTOR |     |     |     | WEIGHT kg |        |
|-------|--------|-------------|--------|----|--------------|--------------|-----|-----|-----|-----------|--------|
|       |        |             | kW     | HP |              | F            | G   | Q   | T   | PUMP      | Q.D.C. |
| THREE | 50/80  | 80DVFU61.5  | 1.5    | 2  | LM65         | 238          | 428 | 160 | 778 | 59        | 14     |
|       |        | 80DVCFU62.2 | 2.2    | 3  | LM65         | 238          | 428 | 160 | 805 | 72        | 14     |
|       |        | 80DVCFU63.7 | 3.7    | 5  | LM65         | 238          | 482 | 160 | 845 | 78        | 14     |

*\*Note: All dimensions are based on 3" discharge.*

**Dimensions**

Project: \_\_\_\_\_ Model: \_\_\_\_\_ Chk'd: \_\_\_\_\_ Date: \_\_\_\_\_

**Model DVFU with Quick Discharge Connector**  
**80DVBFU, 3 to 5HP**  
**80DVFU, 7½HP**

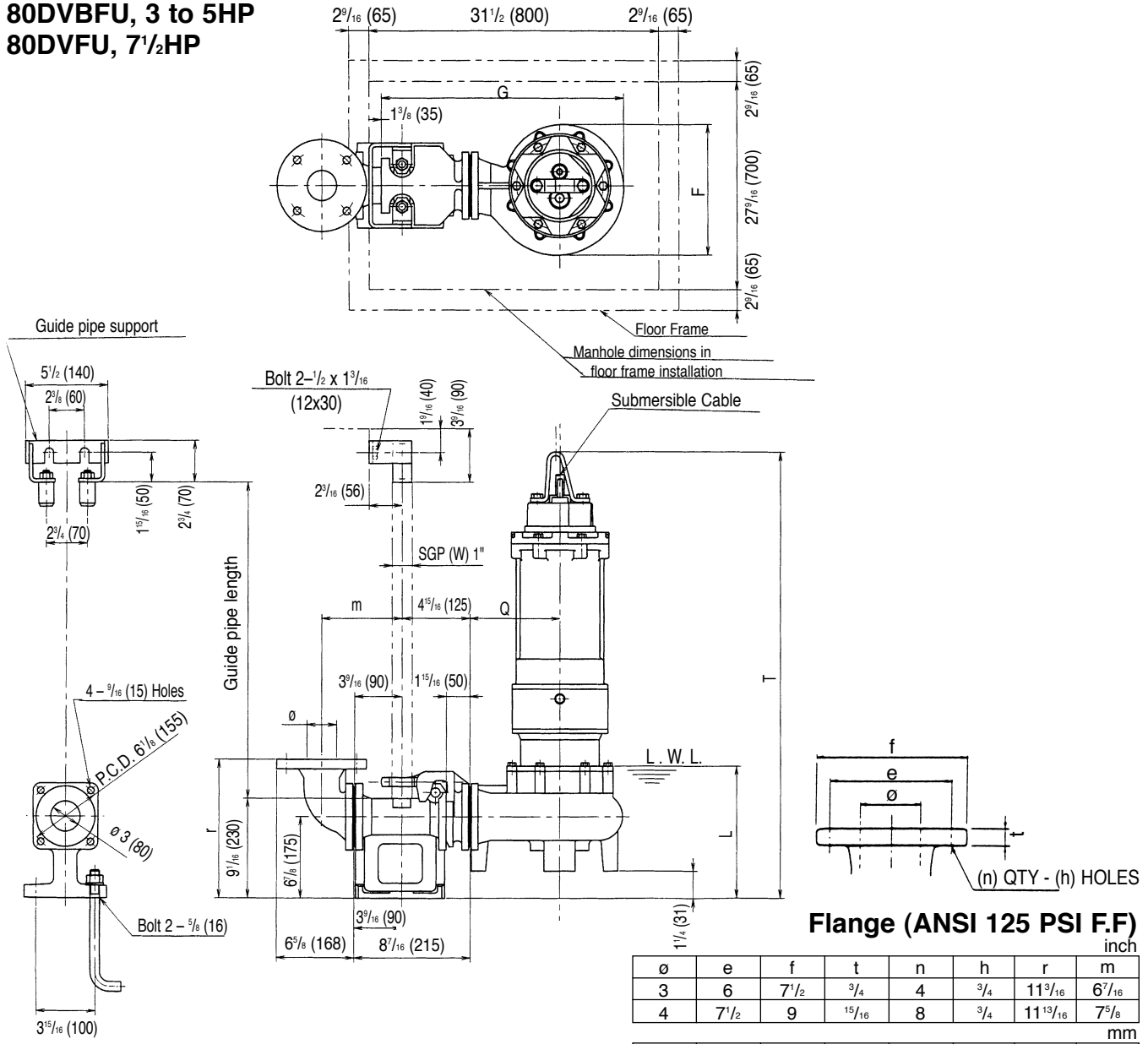

**Dimensions: inch**

| PHASE | SIZE ø | MODEL       | OUTPUT |    | Q.D.C. MODEL | PUMP & MOTOR |         |        |      |         | WEIGHT Lb |        |
|-------|--------|-------------|--------|----|--------------|--------------|---------|--------|------|---------|-----------|--------|
|       |        |             | KW     | HP |              | F            | G       | L      | Q    | T       | PUMP      | Q.D.C. |
| THREE | ¾      | 80DVBFU62.2 | 2.2    | 3  | LM80         | 9¹⁵⁄₁₆       | 18³⁄₈   | 11⁷⁄₁₆ | 6⁷⁄₈ | 33½     | 176       | 37     |
|       |        | 80DVBFU63.7 | 3.7    | 5  | LM80         | 9¹⁵⁄₁₆       | 18³⁄₈   | 11⁷⁄₁₆ | 6⁷⁄₈ | 35¹⁄₁₆  | 176       | 37     |
|       |        | 80DVFU65.5  | 5.5    | 7½ | LM80         | 11¼          | 19¹³⁄₁₆ | 14³⁄₁₆ | 7⁷⁄₈ | 41¹⁵⁄₁₆ | 262       | 37     |

**Dimensions: mm**

| PHASE | SIZE ø | MODEL       | OUTPUT |    | Q.D.C. MODEL | PUMP & MOTOR |     |     |     |      | WEIGHT kg |        |
|-------|--------|-------------|--------|----|--------------|--------------|-----|-----|-----|------|-----------|--------|
|       |        |             | KW     | HP |              | F            | G   | L   | Q   | T    | PUMP      | Q.D.C. |
| THREE | 80/100 | 80DVBFU62.2 | 2.2    | 3  | LM80         | 252          | 460 | 290 | 175 | 851  | 80        | 17     |
|       |        | 80DVBFU63.7 | 3.7    | 5  | LM80         | 252          | 460 | 290 | 175 | 891  | 80        | 17     |
|       |        | 80DVFU65.5  | 5.5    | 7½ | LM80         | 285          | 503 | 360 | 200 | 1065 | 119       | 17     |

**\*Note:** All dimensions are based on 3" discharge.

**Dimensions**

Project: \_\_\_\_\_ Model: \_\_\_\_\_ Chk'd: \_\_\_\_\_ Date: \_\_\_\_\_

**Model DVFU with Quick Discharge Connector**  
**80DVFU, 10HP**  
**80DVBFU, 15HP**  
**80DVCFU, 15 to 30HP**

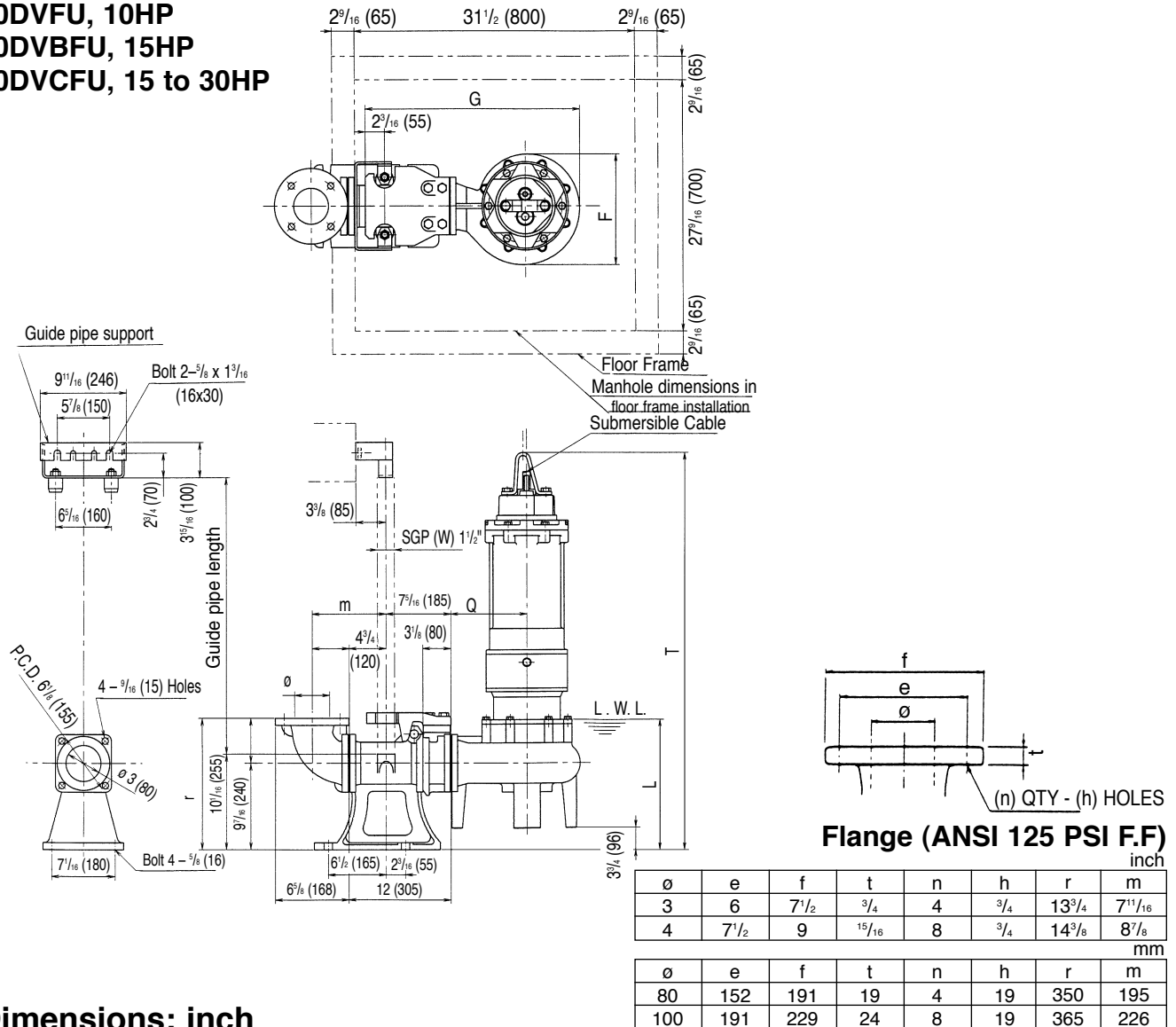

**Dimensions: inch**

| PHASE | SIZE<br>ø | MODEL      | OUTPUT |    | Q.D.C.<br>MODEL | PUMP & MOTOR                    |                                |                                  |                                | WEIGHT Lb                        |      |        |
|-------|-----------|------------|--------|----|-----------------|---------------------------------|--------------------------------|----------------------------------|--------------------------------|----------------------------------|------|--------|
|       |           |            | kW     | HP |                 | F                               | G                              | L                                | Q                              | T                                | PUMP | Q.D.C. |
| THREE | 3/4       | 80DVFU67.5 | 7.5    | 10 | LL80            | 11 <sup>1</sup> / <sub>4</sub>  | 25 <sup>5</sup> / <sub>8</sub> | 16 <sup>15</sup> / <sub>16</sub> | 7 <sup>7</sup> / <sub>8</sub>  | 42 <sup>15</sup> / <sub>16</sub> | 291  | 97     |
|       |           | 80DVBFU611 | 11     | 15 | LL80            | 11 <sup>1</sup> / <sub>4</sub>  | 25 <sup>5</sup> / <sub>8</sub> | 16 <sup>15</sup> / <sub>16</sub> | 7 <sup>7</sup> / <sub>8</sub>  | 46 <sup>9</sup> / <sub>16</sub>  | 390  | 97     |
|       |           | 80DVCFU611 | 11     | 15 | LL80            | 13 <sup>7</sup> / <sub>16</sub> | 25 <sup>5</sup> / <sub>8</sub> | 16 <sup>15</sup> / <sub>16</sub> | 9 <sup>7</sup> / <sub>16</sub> | 46 <sup>9</sup> / <sub>16</sub>  | 406  | 97     |
|       |           | 80DVCFU615 | 15     | 20 | LL80            | 13 <sup>7</sup> / <sub>16</sub> | 25 <sup>5</sup> / <sub>8</sub> | 17 <sup>11</sup> / <sub>16</sub> | 9 <sup>7</sup> / <sub>16</sub> | 49 <sup>1</sup> / <sub>8</sub>   | 503  | 97     |
|       |           | 80DVCFU618 | 18     | 25 | LL80            | 13 <sup>7</sup> / <sub>16</sub> | 25 <sup>5</sup> / <sub>8</sub> | 17 <sup>11</sup> / <sub>16</sub> | 9 <sup>7</sup> / <sub>16</sub> | 50 <sup>11</sup> / <sub>16</sub> | 578  | 97     |
|       |           | 80DVCFU622 | 22     | 30 | LL80            | 13 <sup>7</sup> / <sub>16</sub> | 25 <sup>5</sup> / <sub>8</sub> | 17 <sup>11</sup> / <sub>16</sub> | 9 <sup>7</sup> / <sub>16</sub> | 50 <sup>11</sup> / <sub>16</sub> | 633  | 97     |

**Dimensions: mm**

| PHASE | SIZE<br>ø | MODEL      | OUTPUT |    | Q.D.C.<br>MODEL | PUMP & MOTOR |     |     |     | WEIGHT kg |      |        |
|-------|-----------|------------|--------|----|-----------------|--------------|-----|-----|-----|-----------|------|--------|
|       |           |            | kW     | HP |                 | F            | G   | L   | Q   | T         | PUMP | Q.D.C. |
| THREE | 80/100    | 80DVFU67.5 | 7.5    | 10 | LL80            | 285          | 651 | 430 | 200 | 1090      | 132  | 44     |
|       |           | 80DVBFU611 | 11     | 15 | LL80            | 285          | 651 | 430 | 200 | 1183      | 177  | 44     |
|       |           | 80DVCFU611 | 11     | 15 | LL80            | 342          | 651 | 430 | 240 | 1183      | 184  | 44     |
|       |           | 80DVCFU615 | 15     | 20 | LL80            | 342          | 651 | 450 | 240 | 1248      | 228  | 44     |
|       |           | 80DVCFU618 | 18     | 25 | LL80            | 342          | 651 | 450 | 240 | 1288      | 262  | 44     |
|       |           | 80DVCFU622 | 22     | 30 | LL80            | 342          | 651 | 450 | 240 | 1288      | 287  | 44     |

**\*Note:** All dimensions are based on 3" discharge.

**Dimensions**

Project: \_\_\_\_\_ Model: \_\_\_\_\_ Chk'd: \_\_\_\_\_ Date: \_\_\_\_\_

**Model DVFU with Quick Discharge Connector**  
**100DVFU, 5 to 10HP**  
**100DVBFU, 15HP**  
**100DVCFU, 15 to 20HP**

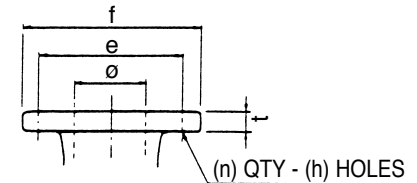
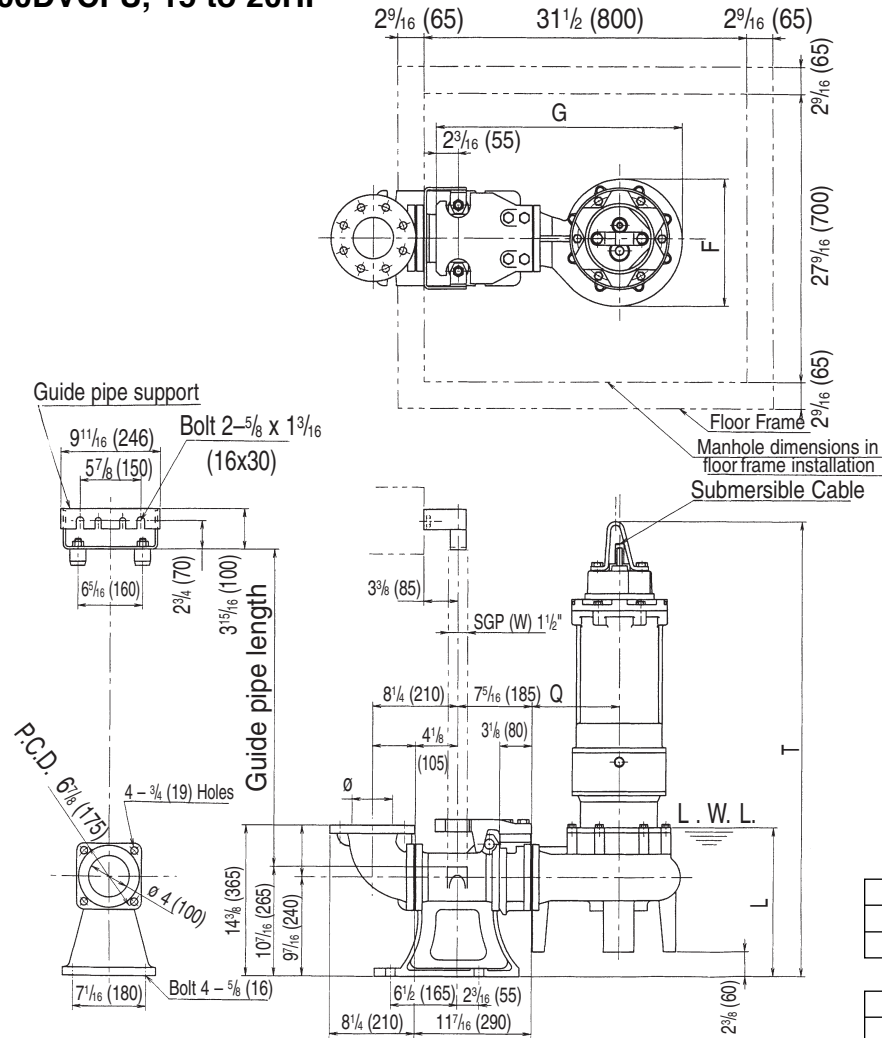

**Flange (ANSI 125 PSI F.F)**

| inch |       |       |       |   |     |
|------|-------|-------|-------|---|-----|
| ø    | e     | f     | t     | n | h   |
| 3    | 6     | 7 1/2 | 3/4   | 4 | 3/4 |
| 4    | 7 1/2 | 9     | 15/16 | 8 | 3/4 |

| mm  |     |     |    |   |    |
|-----|-----|-----|----|---|----|
| ø   | e   | f   | t  | n | h  |
| 80  | 152 | 191 | 19 | 4 | 19 |
| 100 | 191 | 229 | 24 | 8 | 19 |

**Dimensions: inch**

| PHASE | SIZE ø | MODEL       | OUTPUT |       | Q.D.C. MODEL | PUMP & MOTOR |    |        |        |          | WEIGHT Lb |        |
|-------|--------|-------------|--------|-------|--------------|--------------|----|--------|--------|----------|-----------|--------|
|       |        |             | KW     | HP    |              | F            | G  | L      | Q      | T        | PUMP      | Q.D.C. |
| THREE | 3/4    | 100DVFU63.7 | 3.7    | 5     | LL100        | 12 1/8       | 24 | 14 3/4 | 8 7/16 | 38 7/16  | 209       | 101    |
|       |        | 100DVFU65.5 | 5.5    | 7 1/2 | LL100        | 12 1/8       | 24 | 17 7/8 | 8 7/16 | 43 3/4   | 317       | 101    |
|       |        | 100DVFU67.5 | 7.5    | 10    | LL100        | 12 1/8       | 24 | 17 9/8 | 8 7/16 | 43 3/4   | 346       | 101    |
|       |        | 100DVBFU611 | 11     | 15    | LL100        | 12 1/8       | 24 | 17 7/8 | 8 7/16 | 47 3/8   | 452       | 101    |
|       |        | 100DVCFU611 | 11     | 15    | LL100        | 12 1/8       | 24 | 17 9/8 | 8 7/16 | 47 3/8   | 452       | 101    |
|       |        | 100DVCFU615 | 15     | 20    | LL100        | 12 1/8       | 24 | 17 7/8 | 8 7/16 | 49 15/16 | 547       | 101    |

**Dimensions: mm**

| PHASE | SIZE ø | MODEL       | OUTPUT |       | Q.D.C. MODEL | PUMP & MOTOR |     |     |     |      | WEIGHT kg |        |
|-------|--------|-------------|--------|-------|--------------|--------------|-----|-----|-----|------|-----------|--------|
|       |        |             | KW     | HP    |              | F            | G   | L   | Q   | T    | PUMP      | Q.D.C. |
| THREE | 80/100 | 100DVFU63.7 | 3.7    | 5     | LL100        | 308          | 609 | 375 | 215 | 976  | 95        | 46     |
|       |        | 100DVFU65.5 | 5.5    | 7 1/2 | LL100        | 308          | 609 | 448 | 215 | 1111 | 144       | 46     |
|       |        | 100DVFU67.5 | 7.5    | 10    | LL100        | 308          | 609 | 448 | 215 | 1111 | 157       | 46     |
|       |        | 100DVBFU611 | 11     | 15    | LL100        | 308          | 609 | 448 | 215 | 1204 | 205       | 46     |
|       |        | 100DVCFU611 | 11     | 15    | LL100        | 308          | 609 | 448 | 215 | 1204 | 205       | 46     |
|       |        | 100DVCFU615 | 15     | 20    | LL100        | 308          | 609 | 448 | 215 | 1269 | 248       | 46     |

**Dimensions**

Project: \_\_\_\_\_ Model: \_\_\_\_\_ Chk'd: \_\_\_\_\_ Date: \_\_\_\_\_

**Model DVFU with Quick Discharge Connector  
100DVFU, 15 to 30HP**

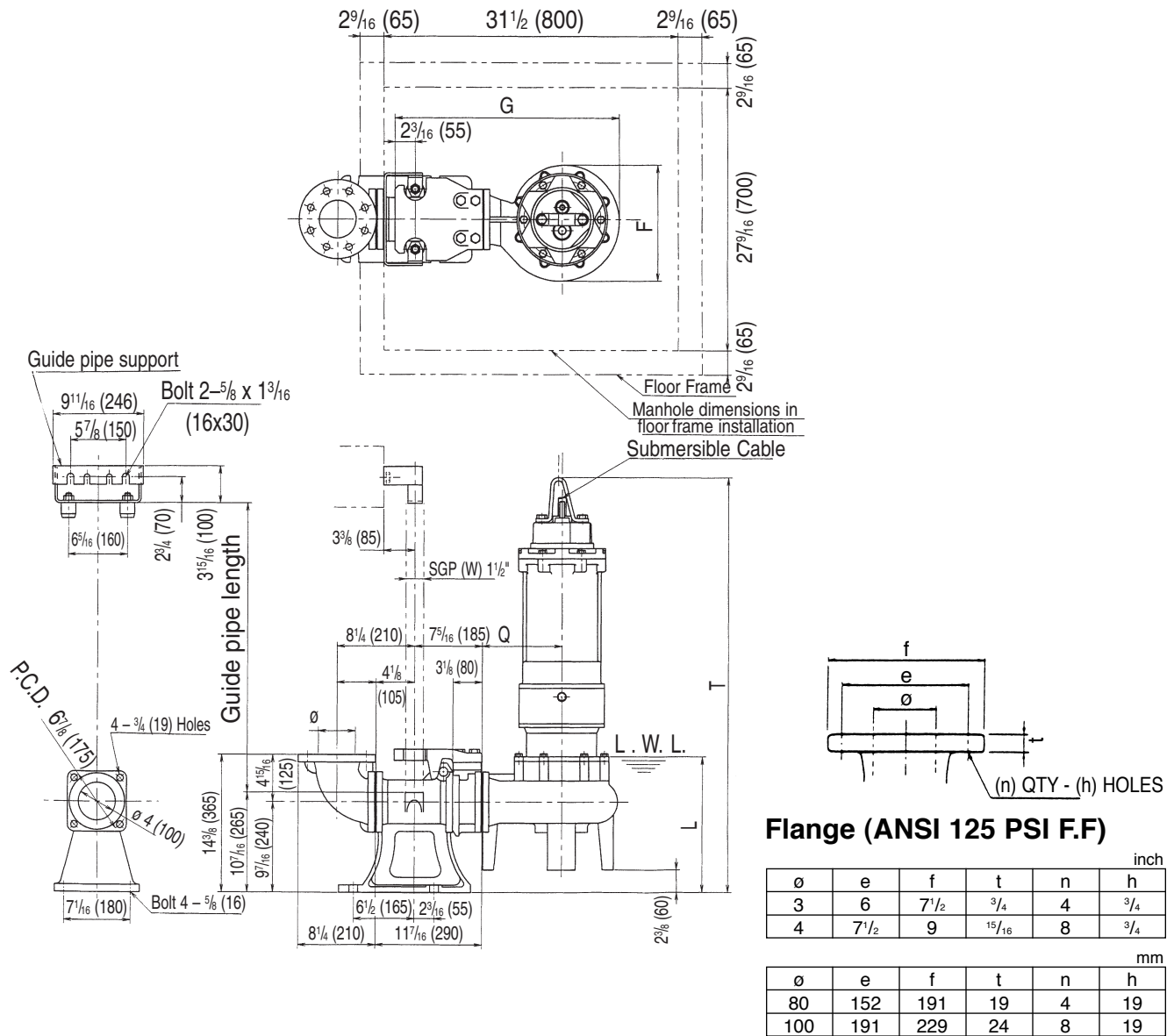

**Flange (ANSI 125 PSI F.F)**

| inch |       |       |       |   |     |
|------|-------|-------|-------|---|-----|
| ø    | e     | f     | t     | n | h   |
| 3    | 6     | 7 1/2 | 3/4   | 4 | 3/4 |
| 4    | 7 1/2 | 9     | 15/16 | 8 | 3/4 |

| mm  |     |     |    |   |    |
|-----|-----|-----|----|---|----|
| ø   | e   | f   | t  | n | h  |
| 80  | 152 | 191 | 19 | 4 | 19 |
| 100 | 191 | 229 | 24 | 8 | 19 |

**Dimensions: inch**

| PHASE | SIZE ø | MODEL      | OUTPUT |    | Q.D.C. MODEL | PUMP & MOTOR |        |         |         |         | WEIGHT Lb |        |
|-------|--------|------------|--------|----|--------------|--------------|--------|---------|---------|---------|-----------|--------|
|       |        |            | kw     | HP |              | F            | G      | L       | Q       | T       | PUMP      | Q.D.C. |
| THREE | 3/4    | 100DVFU611 | 11     | 15 | LL100        | 13 7/8       | 26 1/4 | 17 9/16 | 9 13/16 | 47 7/16 | 445       | 101    |
|       |        | 100DVFU615 | 15     | 20 | LL100        | 13 7/8       | 26 1/4 | 18 5/16 | 9 13/16 | 49 7/8  | 547       | 101    |
|       |        | 100DVFU618 | 18     | 25 | LL100        | 13 7/8       | 26 1/4 | 18 5/16 | 9 13/16 | 51 7/16 | 602       | 101    |
|       |        | 100DVFU622 | 22     | 30 | LL100        | 13 7/8       | 26 1/4 | 18 5/16 | 9 13/16 | 51 7/16 | 668       | 101    |

**Dimensions: mm**

| PHASE | SIZE ø | MODEL      | OUTPUT |    | Q.D.C. MODEL | PUMP & MOTOR |     |     |     |      | WEIGHT kg |        |
|-------|--------|------------|--------|----|--------------|--------------|-----|-----|-----|------|-----------|--------|
|       |        |            | kw     | HP |              | F            | G   | L   | Q   | T    | PUMP      | Q.D.C. |
| THREE | 80/100 | 100DVFU611 | 11     | 15 | LL100        | 352          | 666 | 446 | 250 | 1202 | 202       | 46     |
|       |        | 100DVFU615 | 15     | 20 | LL100        | 352          | 666 | 465 | 250 | 1267 | 248       | 46     |
|       |        | 100DVFU618 | 18     | 25 | LL100        | 352          | 666 | 465 | 250 | 1307 | 273       | 46     |
|       |        | 100DVFU622 | 22     | 30 | LL100        | 352          | 666 | 465 | 250 | 1307 | 303       | 46     |

Dimensions

Project: \_\_\_\_\_ Model: \_\_\_\_\_ Chk'd: \_\_\_\_\_ Date: \_\_\_\_\_

**Model DVFU with Quick Discharge Connector**  
**150DVBFU, 15 to 30HP**  
**150DVCFU, 25 to 30HP**

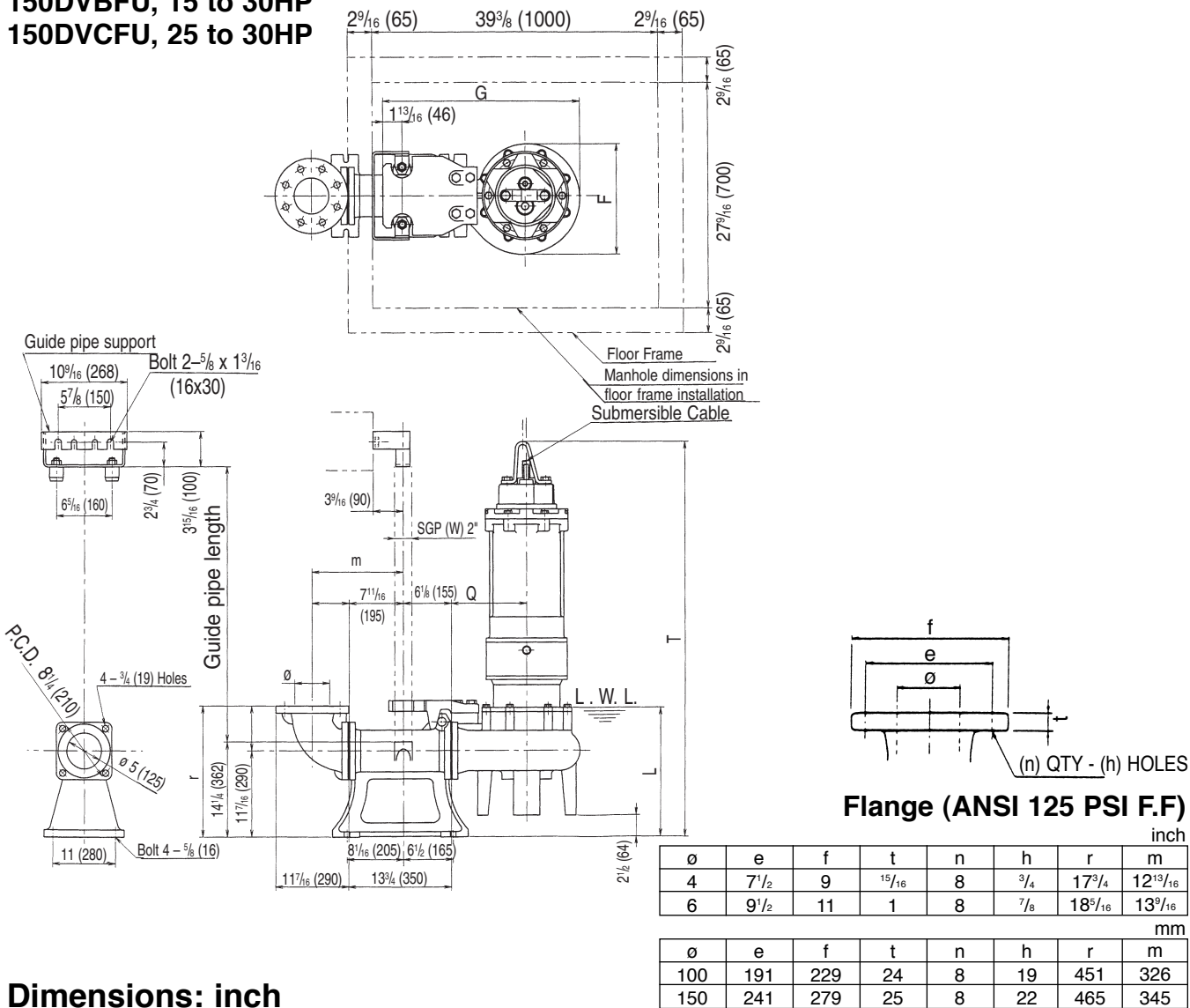

Dimensions: inch

| PHASE | SIZE ø | MODEL       | OUTPUT |    | Q.D.C. MODEL | PUMP & MOTOR |          |         |        |         | WEIGHT Lb |        |
|-------|--------|-------------|--------|----|--------------|--------------|----------|---------|--------|---------|-----------|--------|
|       |        |             | KW     | HP |              | F            | G        | L       | Q      | T       | PUMP      | Q.D.C. |
| THREE | 4/6    | 150DVBFU611 | 11     | 15 | LL125        | 13 1/16      | 23 11/16 | 21 9/16 | 9 1/4  | 50 1/2  | 514       | 143    |
|       |        | 150DVBFU615 | 15     | 20 | LL125        | 13 1/16      | 23 11/16 | 21 9/16 | 9 1/4  | 53 1/16 | 608       | 143    |
|       |        | 150DVBFU618 | 18     | 25 | LL125        | 13 1/16      | 23 11/16 | 21 9/16 | 9 1/4  | 54 5/8  | 683       | 143    |
|       |        | 150DVBFU622 | 22     | 30 | LL125        | 13 1/16      | 23 11/16 | 21 9/16 | 9 1/4  | 54 5/8  | 739       | 143    |
|       |        | 150DVCFU618 | 18     | 25 | LL125        | 15 1/8       | 26 1/8   | 21 7/16 | 10 5/8 | 54 1/2  | 708       | 143    |
|       |        | 150DVCFU622 | 22     | 30 | LL125        | 15 1/8       | 26 1/8   | 21 7/16 | 10 5/8 | 54 1/2  | 763       | 143    |

Dimensions: mm

| PHASE | SIZE ø  | MODEL       | OUTPUT |    | Q.D.C. MODEL | PUMP & MOTOR |     |     |     |      | WEIGHT kg |        |
|-------|---------|-------------|--------|----|--------------|--------------|-----|-----|-----|------|-----------|--------|
|       |         |             | KW     | HP |              | F            | G   | L   | Q   | T    | PUMP      | Q.D.C. |
| THREE | 100/150 | 150DVBFU611 | 11     | 15 | LL125        | 332          | 602 | 547 | 235 | 1283 | 233       | 65     |
|       |         | 150DVBFU615 | 15     | 20 | LL125        | 332          | 602 | 547 | 235 | 1348 | 276       | 65     |
|       |         | 150DVBFU618 | 18     | 25 | LL125        | 332          | 602 | 547 | 235 | 1387 | 310       | 65     |
|       |         | 150DVBFU622 | 22     | 30 | LL125        | 332          | 602 | 547 | 235 | 1387 | 335       | 65     |
|       |         | 150DVCFU618 | 18     | 25 | LL125        | 384          | 663 | 544 | 270 | 1384 | 321       | 65     |
|       |         | 150DVCFU622 | 22     | 30 | LL125        | 384          | 663 | 544 | 270 | 1384 | 346       | 65     |



**Sectional View**

Project:

Model:

Chk'd:

Date:

**2 to 5HP**

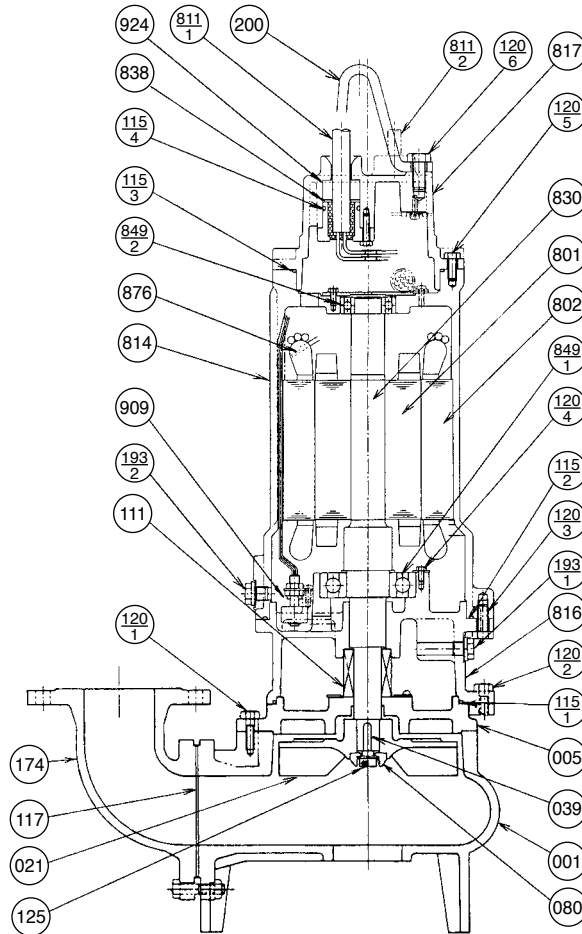

| PART NO. | PART NAME           | MATERIAL      | ASTM, AISI CODE | NO. FOR 1 UNIT |
|----------|---------------------|---------------|-----------------|----------------|
| 001      | CASING              | CAST IRON     | A48 Class 30    | 1              |
| 005      | INTERMEDIATE CASING | CAST IRON     | A48 Class 30    | 1              |
| †021     | IMPELLER            | CAST IRON     | A48 Class 30    | 1              |
| 039      | KEY                 | 420 STAINLESS | AISI420         | 1              |
| 080      | BUSHING             | STEEL         | A283 Grade D    | 1              |
| †111     | MECHANICAL SEAL     | —             |                 | 1 SET          |
| †115-1   | O-RING              | RUBBER (NBR)  |                 | 1              |
| †115-2   | O-RING              | RUBBER (NBR)  |                 | 1              |
| †115-3   | O-RING              | RUBBER (NBR)  |                 | 1              |
| †115-4   | O-RING              | RUBBER (NBR)  |                 | 2              |
| †117     | GASKET              |               |                 | 1              |
| 120-1    | BOLT                | 304 STAINLESS | AISI304         | 4              |
| 120-2    | BOLT                | 304 STAINLESS | AISI304         | 4              |
| 120-3    | BOLT                | 304 STAINLESS | AISI304         | 4              |
| 120-4    | BOLT                | 304 STAINLESS | AISI304         | 3              |
| 120-5    | BOLT                | 304 STAINLESS | AISI304         | 4              |
| 120-6    | BOLT                | 304 STAINLESS | AISI304         | 2              |
| 125      | BOLT                | 304 STAINLESS | AISI304         | 1              |

| PART NO. | PART NAME        | MATERIAL      | ASTM, AISI CODE | NO. FOR 1 UNIT |
|----------|------------------|---------------|-----------------|----------------|
| 174      | DISCHARGE ELBOW  | CAST IRON     | A48 Class 30    | 1              |
| 193-1    | PLUG             | 304 STAINLESS | AISI304         | 1              |
| 193-2    | PLUG             | 304 STAINLESS | AISI304         | 1              |
| 200      | LIFTING HANGER   | STEEL         | A283 Grade D    | 1              |
| 801      | ROTOR            | —             |                 | 1              |
| 802      | STATOR           | —             |                 | 1              |
| 811-1    | POWER CABLE      | —             |                 | 1              |
| 811-2    | CONTROL CABLE    | —             |                 | 1              |
| 814      | MOTOR COVER      | CAST IRON     | A48 Class 30    | 1              |
| 816      | BRACKET          | CAST IRON     | A48 Class 30    | 1              |
| 817      | BRACKET          | CAST IRON     | A48 Class 30    | 1              |
| 830      | SHAFT            | 403 STAINLESS | AISI403         | 1              |
| 838      | WASHER           | 304 STAINLESS | AISI304         | 2              |
| †849-1   | BALL BEARING     | —             |                 | 1              |
| †849-2   | BALL BEARING     | —             |                 | 1              |
| 876      | MOTOR PROTECTOR  | —             |                 | 3              |
| 909      | LEAKAGE DETECTOR | —             |                 | 1              |
| 924      | PACKING          | RUBBER (NBR)  |                 | 2              |

Motors are purchased as a complete unit

†: Recommended spare parts



**EBARA Fluid Handling**  
 www.pumpsebara.com  
 (t) 803 327 5005 , (f) 803 327 5097



**Sectional View**

Project: \_\_\_\_\_ Model: \_\_\_\_\_ Chk'd: \_\_\_\_\_ Date: \_\_\_\_\_

**7½ to 10HP**

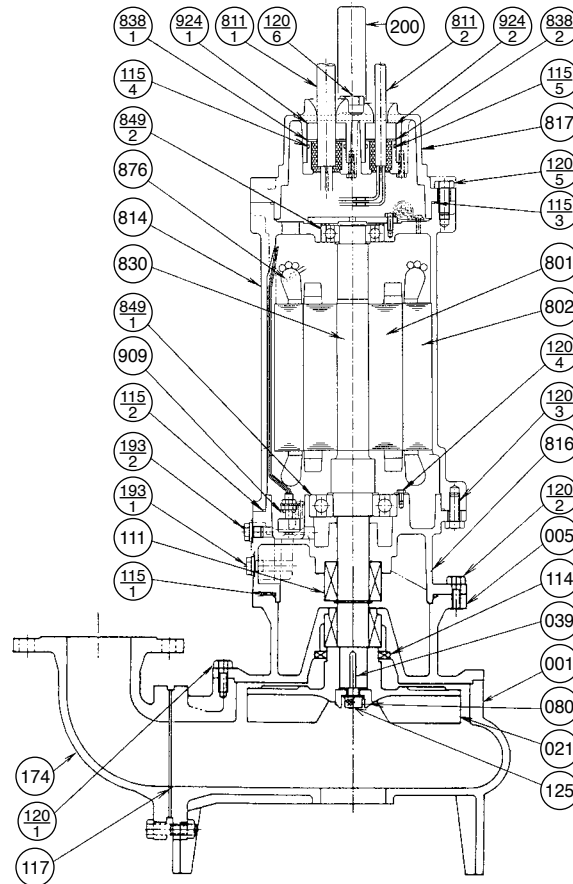

| PART NO. | PART NAME           | MATERIAL      | ASTM, AISI CODE | NO. FOR 1 UNIT | PART NO. | PART NAME        | MATERIAL        | ASTM, AISI CODE | NO. FOR 1 UNIT |
|----------|---------------------|---------------|-----------------|----------------|----------|------------------|-----------------|-----------------|----------------|
| 001      | CASING              | CAST IRON     | A48 Class 30    | 1              | 174      | DISCHARGE ELBOW  | CAST IRON       | A48 Class 30    | 1              |
| 005      | INTERMEDIATE CASING | CAST IRON     | A48 Class 30    | 1              | 193-1    | PLUG             | 304 STAINLESS   | AISI304         | 1              |
| 021      | IMPELLER            | CAST IRON     | A48 Class 30    | 1              | 193-2    | PLUG             | 304 STAINLESS   | AISI304         | 1              |
| 039      | KEY                 | 420 STAINLESS | AISI420         | 1              | 200      | LIFTING HANGER   | STEEL           | A283 Grade D    | 1              |
| 080      | BUSHING             | STEEL         | A283 Grade D    | 1              | 801      | ROTOR            | —               |                 | 1              |
| †111     | MECHANICAL SEAL     | —             |                 | 1 SET          | 802      | STATOR           | —               |                 | 1              |
| †114     | OIL SEAL            | RUBBER (NBR)  |                 | 1              | 811-1    | POWER CABLE      | —               |                 | 1              |
| †115-1   | O-RING              | RUBBER (NBR)  |                 | 1              | 811-2    | CONTROL CABLE    | —               |                 | 1              |
| †115-2   | O-RING              | RUBBER (NBR)  |                 | 1              | 814      | MOTOR COVER      | CAST IRON       | A48 Class 30    | 1              |
| †115-3   | O-RING              | RUBBER (NBR)  |                 | 1              | 816      | BRACKET          | CAST IRON       | A48 Class 30    | 1              |
| †115-4   | O-RING              | RUBBER (NBR)  |                 | 1              | 817      | BRACKET          | CAST IRON       | A48 Class 30    | 1              |
| †115-5   | O-RING              | RUBBER (NBR)  |                 | 1              | 830      | SHAFT            | 420J2 STAINLESS | AISI420         | 1              |
| †117     | GASKET              |               |                 | 1              | 838-1    | WASHER           | 304 STAINLESS   | AISI304         | 1              |
| 120-1    | BOLT                | 304 STAINLESS | AISI304         | 8              | 838-2    | WASHER           | 304 STAINLESS   | AISI304         | 1              |
| 120-2    | BOLT                | 304 STAINLESS | AISI304         | 4              | †849-1   | BALL BEARING     | —               |                 | 1              |
| 120-3    | BOLT                | 304 STAINLESS | AISI304         | 6              | †849-2   | BALL BEARING     | —               |                 | 1              |
| 120-4    | BOLT                | 304 STAINLESS | AISI304         | 3              | 876      | MOTOR PROTECTOR  | —               |                 | 3              |
| 120-5    | BOLT                | 304 STAINLESS | AISI304         | 4              | 909      | LEAKAGE DETECTOR | —               |                 | 1              |
| 120-6    | BOLT                | 304 STAINLESS | AISI304         | 2              | 924-1    | PACKING          | RUBBER (NBR)    |                 | 1              |
| 125      | BOLT                | 304 STAINLESS | AISI304         | 1              | 924-2    | PACKING          | RUBBER (NBR)    |                 | 1              |

Motors are purchased as a complete unit

†: Recommended spare parts

**Sectional View**

Project:

Model:

Chk'd:

Date:

**15 to 30HP**

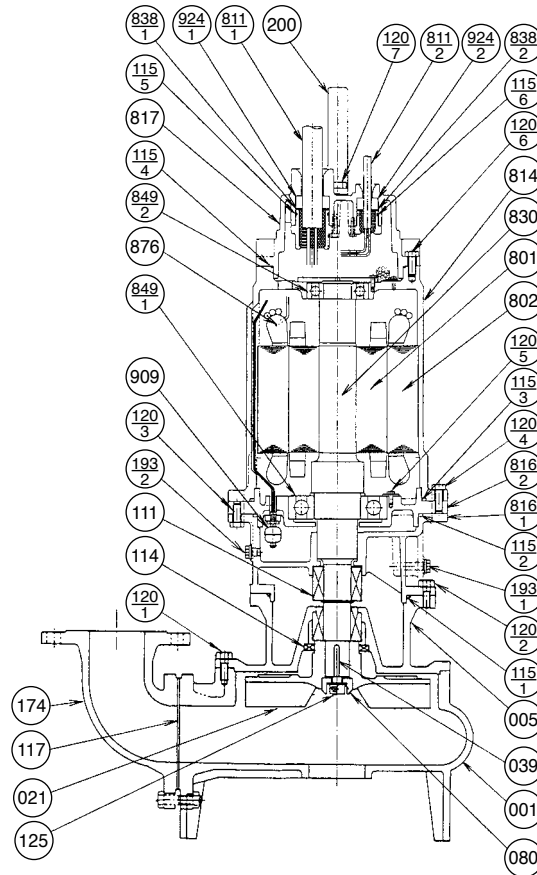

| PART NO. | PART NAME           | MATERIAL      | ASTM, AISI CODE | NO. FOR 1 UNIT | PART NO. | PART NAME        | MATERIAL        | ASTM, AISI CODE | NO. FOR 1 UNIT |
|----------|---------------------|---------------|-----------------|----------------|----------|------------------|-----------------|-----------------|----------------|
| 001      | CASING              | CAST IRON     | A48 Class 30    | 1              | 174      | DISCHARGE ELBOW  | CAST IRON       | A48 Class 30    | 1              |
| 005      | INTERMEDIATE CASING | CAST IRON     | A48 Class 30    | 1              | 193-1    | PLUG             | 304 STAINLESS   | AISI304         | 1              |
| 021      | IMPELLER            | CAST IRON     | A48 Class 30    | 1              | 193-2    | PLUG             | 304 STAINLESS   | AISI304         | 1              |
| 039      | KEY                 | 420 STAINLESS | AISI420         | 1              | 200      | LIFTING HANGER   | STEEL           | A283 Grade D    | 1              |
| 080      | BUSHING             | STEEL         | A283 Grade D    | 1              | 801      | ROTOR            | —               |                 | 1              |
| †111     | MECHANICAL SEAL     | —             |                 | 1 SET          | 802      | STATOR           | —               |                 | 1              |
| †114     | OIL SEAL            | RUBBER (NBR)  |                 | 1              | 811-1    | POWER CABLE      | —               |                 | 1              |
| †115-1   | O-RING              | RUBBER (NBR)  |                 | 1              | 811-2    | CONTROL CABLE    | —               |                 | 1              |
| †115-2   | O-RING              | RUBBER (NBR)  |                 | 1              | 814      | MOTOR FRAME      | CAST IRON       | A48 Class 30    | 1              |
| †115-3   | O-RING              | RUBBER (NBR)  |                 | 1              | 816-1    | BRACKET          | CAST IRON       | A48 Class 30    | 1              |
| †115-4   | O-RING              | RUBBER (NBR)  |                 | 1              | 816-2    | BRACKET          | CAST IRON       | A48 Class 30    | 1              |
| †115-5   | O-RING              | RUBBER (NBR)  |                 | 1              | 817      | BRACKET          | CAST IRON       | A48 Class 30    | 1              |
| †115-6   | O-RING              | RUBBER (NBR)  |                 | 1              | 830      | SHAFT            | 420J2 STAINLESS | AISI420         | 1              |
| †117     | GASKET              |               |                 | 1              | 838-1    | WASHER           | 304 STAINLESS   | AISI304         | 1              |
| 120-1    | BOLT                | 304 STAINLESS | AISI304         | 8              | 838-2    | WASHER           | 304 STAINLESS   | AISI304         | 1              |
| 120-2    | BOLT                | 304 STAINLESS | AISI304         | 4              | †849-1   | BALL BEARING     | —               |                 | 1              |
| 120-3    | BOLT                | 304 STAINLESS | AISI304         | 6              | †849-2   | BALL BEARING     | —               |                 | 1              |
| 120-4    | BOLT                | 304 STAINLESS | AISI304         | 6              | 876      | MOTOR PROTECTOR  | —               |                 | 3              |
| 120-5    | BOLT                | 304 STAINLESS | AISI304         | 3              | 909      | LEAKAGE DETECTOR | —               |                 | 1              |
| 120-6    | BOLT                | 304 STAINLESS | AISI304         | 6              | 924-1    | PACKING          | RUBBER (NBR)    |                 | 1              |
| 120-7    | BOLT                | 304 STAINLESS | AISI304         | 2              | 924-2    | PACKING          | RUBBER (NBR)    |                 | 1              |
| 125      | BOLT                | 304 STAINLESS | AISI304         | 1              |          |                  |                 |                 |                |

Motors are purchased as a complete unit

†: Recommended spare parts

