

---

# Submersible Slurry Pumps

Model ENZX



Operating Instructions, Installation & Maintenance Manual

---



EBARA Fluid Handling

EBARA International Corporation

**Operating, Installation and Maintenance**

**Contents**

Section	Page
Safety Information and Warning .....	2
General Information .....	3
Operating Conditions .....	3
Model Designation .....	3
Performance Curves .....	4
Operation and Installation.....	5
Maintenance and Repairs .....	6
Troubleshooting Guide .....	7
Sectional View / Part Reference .....	8
Warranty .....	24



**WARNING**

Please read this manual and warnings carefully before installation and operation. Keep it with the equipment at all times. Please pay close attention to all instructions in this manual. Warnings in this manual provide information for safe use of your pump and instructions for preventing injury to those operating it.

**Installation and service by qualified personnel only!**

1. The oil chamber must be filled with appropriate amount of oil before operation. Refer to chart below.
2. Please check the insulation of motor before operation; it should be more than 50 MΩ.
3. The power cable should not be pulled tightly or damage may occur. The pump should be lifted with the eyebolts located on the top of the motor. **CAUTION: DO NOT MEG THE CONTROL CABLE!**
4. Please check the direction of rotation of the pump set (the correct rotation direction should be clockwise from motor side or counter clockwise when viewed from the suction side).
5. All protection devices are low voltage device ( $\leq 36V$ ); please check the open and close of the device or resistance to earth by multimeter. **High voltage testers should not be used to avoid damage to the protection device.**
6. Maximum specific gravity of liquid should not exceed 1.30.
7. The pump should be totally submerged during operation.

**Oil Specs**

HP Range	Approximate Amount
7.5 to 20	1 qt
30	1 1/4 qt

**Note: L-TSA 32# turbine oil should be used.**

**Note: Oil should be level with oil drain hole when standing vertical.**



**Operating, Installation and Maintenance**

**General Information**

The EBARA ENZX series submersible slurry pump is designed for continuous operation in tough, abrasive heavy industry applications. The pump features high chrome iron construction for liquid end components such as the casing, agitator, wear liners, and impeller which are designed for a long service life in tough applications where other pumps of inferior construction may fail. The motor features a double mechanical seal arrangement that operates in an oil bath away from the pumped fluid to prolong service life. In addition, the motor has thermal overload and moisture detection float switch to notify the user of any pump problems. The robust construction and motor features allow the model ENZX to successfully operate in conditions where other pumps will fail.

**Operating Conditions**

- Power Source: 460V, 60Hz, 3 Phase.
- Max. Temperature of Liquid: 40°C, 104°F
- Max. Concentration of Solids: should not exceed 30%, Max. specific gravity not more than 1.30
- Max. Submersed Depth: 50ft (the motor must be submersed in liquid)
- The best installation is vertical, max. incline should not exceed 10°

**Note:** If operating condition is different than above, please specify with order.

**Model Designation**

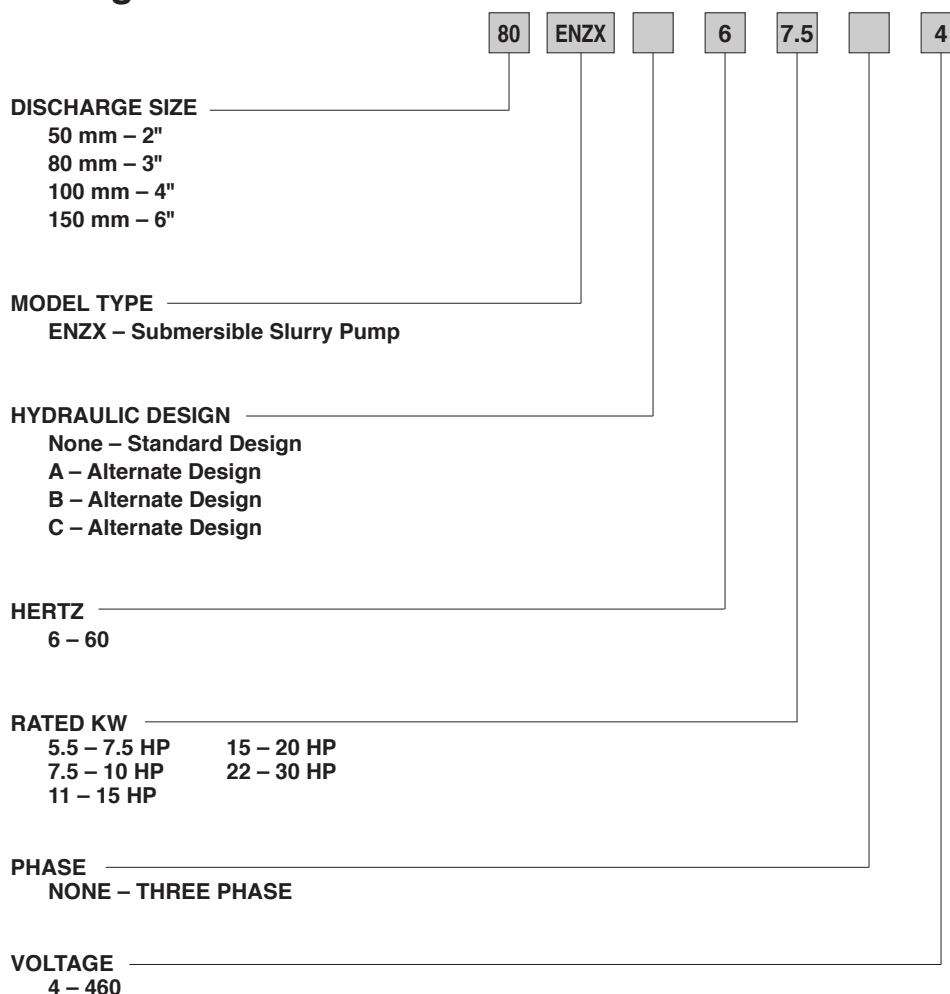

### Performance Curves

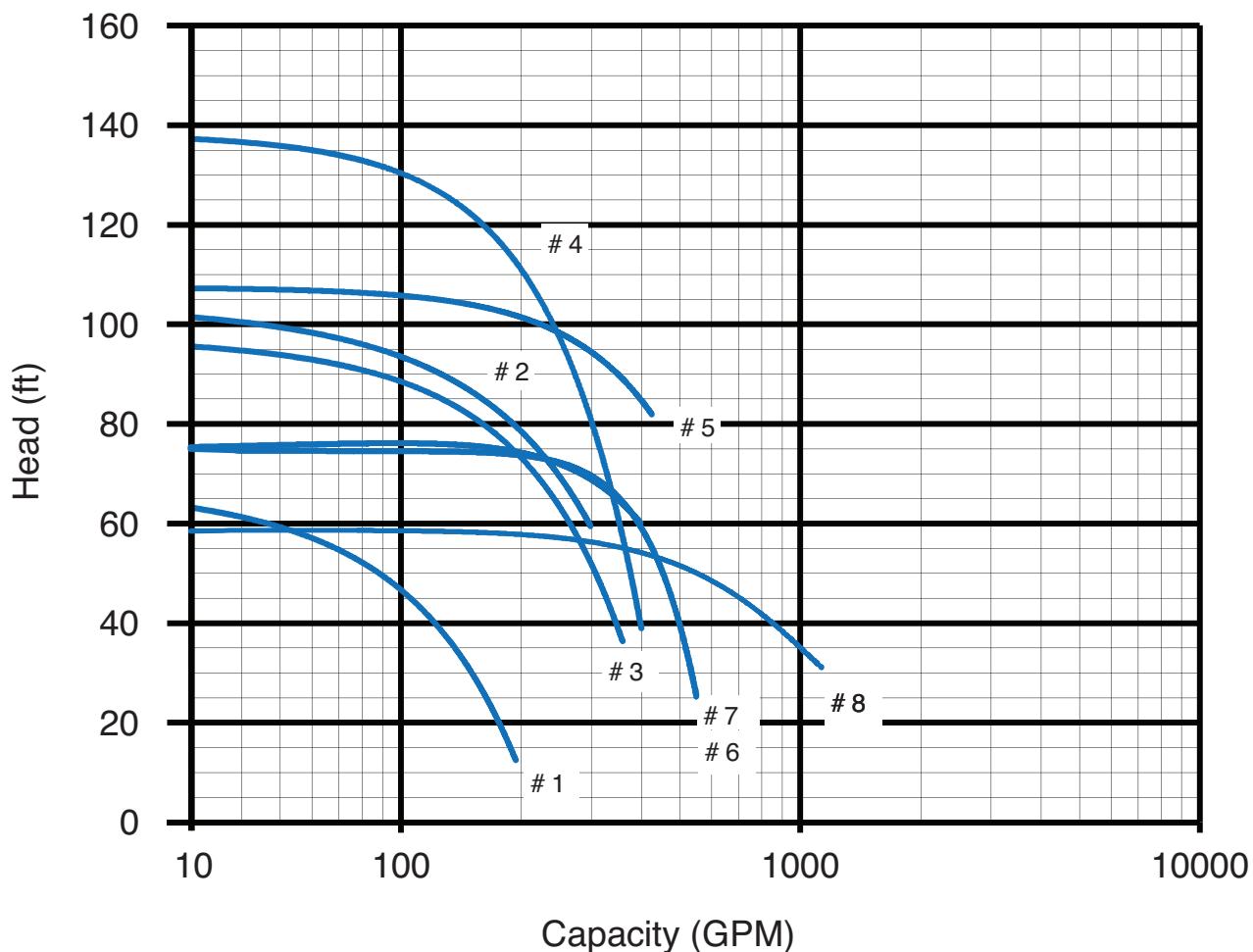

- 1 – 50ENZX65.54
- 2 – 80ENZX67.54
- 3 – 80ENZX6114
- 4 – 80ENZX6154\*
- 5 – 100ENZXA6154
- 6 – 100ENZXB6154
- 7 – 100ENZXC6154
- 8 – 150ENZX6224

*\*Two-Stage Model*

Operating, Installation and Maintenance

Operating Features

- a. Motor is protected by double mechanical seal and lip seals to prevent the entry of water and other impurities into motor.
- b. An agitator fitted on the end of main impeller mixes the solid and liquid, allowing the pump to lift the liquid and solid together. The wet parts of the pump are constructed of a hard chrome iron material (56.8 HRC) designed to prolong service life.
- c. Motor and pump are submersed in liquid, saving installation space, protecting the equipment, allowing ease of maintenance, and greatly reducing operating noise.
- d. The motor has been designed to include several internal protection measures; refer to chart below:

Protection Devices

HP Range	Location	Device	No. of Wires	Open/ Closed	Signal
All	Winding Wire	Thermal Protector	2	N.C.	Alarm
7.5 to 20	Bottom of motor chamber	Leakage Detector (Float Switch)	2	N.O.	Alarm
30	Bottom of motor chamber	Leakage Detector (Resistance Device)	1	-	Alarm

Notes:

- 1. All protection devices are low voltage device ( $\leq 36V$ ). Please check the open and close of device or resistance to earth by multimeter.

**CAUTION!** High voltage testers should not be used. This will result in damage to the protection device.



**WARNING!**

- 2. If wired to an alarm type control box properly, the protection devices will automatically stop the pump when a failure is detected.

Standard Connections

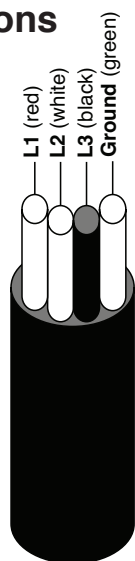

**Power Cable**  
7.5 - 20 HP models

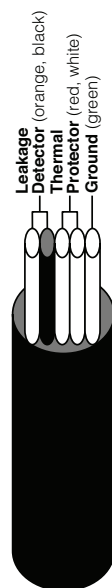

**Sensor Cable**  
7.5 - 20 HP models

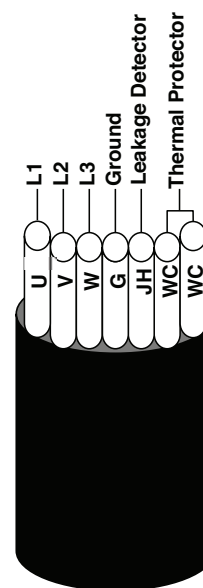

**Power Cable**  
30 HP models



## Installation and Operation



**WARNING!** Check that the power is locked off and disconnected before working on pump. All electrical work should be performed by a qualified electrician and all national and local electrical codes must be observed.

### Inspection Before Installation

1. Please ensure that working site conditions can meet pump operation requirements.
2. Please be sure that the actual flow and head is the same as the performance curve. If the actual flow is more than 120% of the rated flow, there could be possible damage to the motor.
3. Check that the pump, power cable, and control cable are in good condition.
4. Please check that supply voltage and frequency are the same as on pump name plate.
5. Please check oil level: when the pump is vertical, the oil level should reach the oil filling hole. Refer to chart on page 2.

### Notes:

Please check the voltage, working current, and flow. If there is any pump vibration during operation, please stop pump immediately and check to see if any of the following has occurred:

1. Working current is greater than rated current.
2. If the flow is less than 20% of the rated flow or the water flow has stopped.
3. The pump is not fully submerged in water.
4. The voltage is too high or too low ( $460V \pm 0\%$ ).
5. Obvious causes of vibration or noise.

### Installation

1. Cable Connection: The power cable should be installed by a professional electrician.
  - a) Insulation should not be less than 50 M $\Omega$ .
  - b) Please check pump rotation, ensuring that from the motor side the pump is running clockwise. If the rotation is not right, please correct and connect again.
2. Pump Installation
  - a) Lift the pump by the eye bolts located on the top of the motor and submerge the pump in water, ensuring the pump is not connected to power. Connect the power cable, then connect pipe to pump outlet.  
**CAUTION!: DO NOT MEG THE CONTROL CABLE!**



**WARNING!** Disconnect power cable from power source before servicing unit. Normal maintenance should be done by qualified personnel.

### Maintenance and Repairs

1. When pump has not run for an extended period, please lift and clean pump surface, remove all impurities, wipe oil from surface and store in a dry location.
2. When pump operation has exceeded 2500 hours, check all fasteners and seals. Replace oil or mechanical seals as need.
3. The pump must be inspected at least once a year. Replace parts as needed, such as casings, impellers, casing covers, agitators, oil seals, etc.
4. After reassembling pump, conduct an air pressure test for motor and mech. seal chamber. There should be no leakage within 5 minutes under 29 PSI.



**Troubleshooting Guide**

Faults	Problem	Solution
No liquid lifting or deficient	1. Reverse rotation of motor	1. Change any two leads of the three phases
	2. Pipe or impeller blocked	2. Clear suction area
	3. Impeller drop down or damaged	3. Re-secure or change impeller
Uneven running (Vibration)	1. Pump head too low or pump cavitation	1. Replace pump or reset valve
	2. Impeller damaged	2. Replace impeller
	3. Bearing damaged	3. Replace bearing
	4. Impeller friction	4. Reset impeller gap
Insulation failure	1. Cable damaged	1. Replace cable and dry motor
	2. Mechanical seal failure	2. Replace seal and dry motor
	3. O ring failure	3. Replace O ring and dry motor
	4. Water into cable	4. Replace cable and dry motor
Current excessive or motor temperature too high	1. The pump is locked	1. Free impeller
	2. Medium density and viscosity is excessive	2. Adjust medium density and viscosity.
	3. Bearing damaged	3. Replace bearing
	4. Working voltage is too low	4. Reset voltage
Sudden current drop	1. Pipe or pump blocked	1. Cleaning pump or pipe
	2. Water level is too low	2. Filling medium
	3. Impeller damaged	3. Replace impeller
Thermal protection (WC) alarm	1. Motor out of water	1. Reset pump installation or install cooling device
	2. Voltage low	2. Reset voltage
	3. Bearing damaged	3. Replace bearing
	4. Trouble with cooling device	4. Clean cooling device
Leak protection (XL、JH) alarm	1. Mechanical seal failure	1. Replace seal and dry motor
	2. O ring failure	2. Replace O ring and dry motor

If the fault cannot be remedied, please contact EBARA FHD customer service directly by phone: (803) 327-5005 or e-mail: [customer\\_service@pumpsebara.com](mailto:customer_service@pumpsebara.com).

**Model 50ENZX65.54**

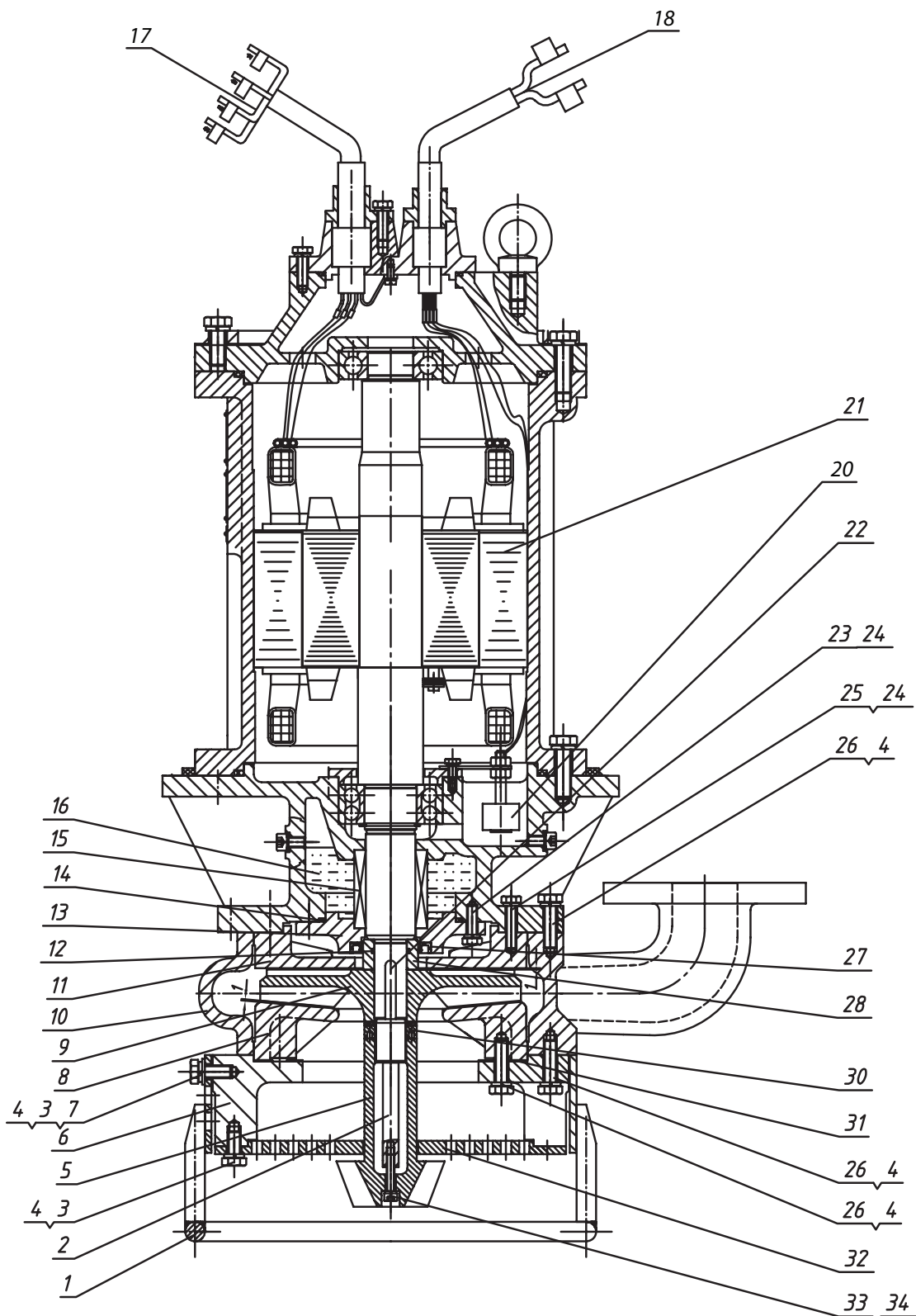



## Operating, Installation and Maintenance

## Model 50ENZX65.54

## Sectional View - Parts Reference

Item No.	Part Description	Part Number	QTY for 1 pump	Material
1	Stand	ENZX75019	1	304 Stainless Steel
2	Threaded Shaft Extension	ENZX75001	1	304 Stainless Steel
3	Bolt M10X20	-	8	304 Stainless Steel
4	Washer 10	-	26	304 Stainless Steel
5	Agitator	ENZX75002	1	High Chrome Iron
6	Suction Frame	ENZX75005	1	Cast Iron
7	Washer 10	-	4	304 Stainless Steel
8	Suction Liner	ENZX75006	1	High Chrome Iron
9	Impeller	ENZX75008	1	High Chrome Iron
10	Pump Casing	ENZX75007	1	High Chrome Iron
11	Upper Liner	ENZX75010	1	High Chrome Iron
12	O-Ring	ENZX75013*	1	Buna
13	Lower Mech Seal Chamber Cover	ENZX75026	1	Cast Iron
14	O-Ring	ENZX75013*	1	Buna
15	Mechanical Seal	ENZX75012	1	-
16	L-TSA 32# Turbine Oil	-	-	-
17	Power Cable	ENZX75016	1	-
18	Control Cable	ENZX75017	1	-
20	Leakage Detector	ENZX75018	1	-
21	Motor Assembly	-	1	Cast Iron
22	Key C8X45	ENZX75020	1	304 Stainless Steel
23	Bolt M8X25	-	8	304 Stainless Steel
24	Washer 8	-	16	304 Stainless Steel
25	Bolt M8X35	-	8	304 Stainless Steel
26	Bolt M10X35	-	18	304 Stainless Steel
27	Lip Seal	ENZX75014	1	-
28	Wear Bushing	ENZX75015	1	304 Stainless Steel
30	Impeller Nut	ENZX75009	1	304 Stainless Steel
31	Adjustment Washer	ENZX75021	-	Brass
32	Strainer	ENZX75022	1	304 Stainless Steel
33	Screw M6X30	ENZX75027**	1	304 Stainless Steel
34	Washer 6	ENZX75027**	1	304 Stainless Steel

\* O-Ring Kit

\*\* Agitator Bolt Kit



**Model 80ENZX67.54**

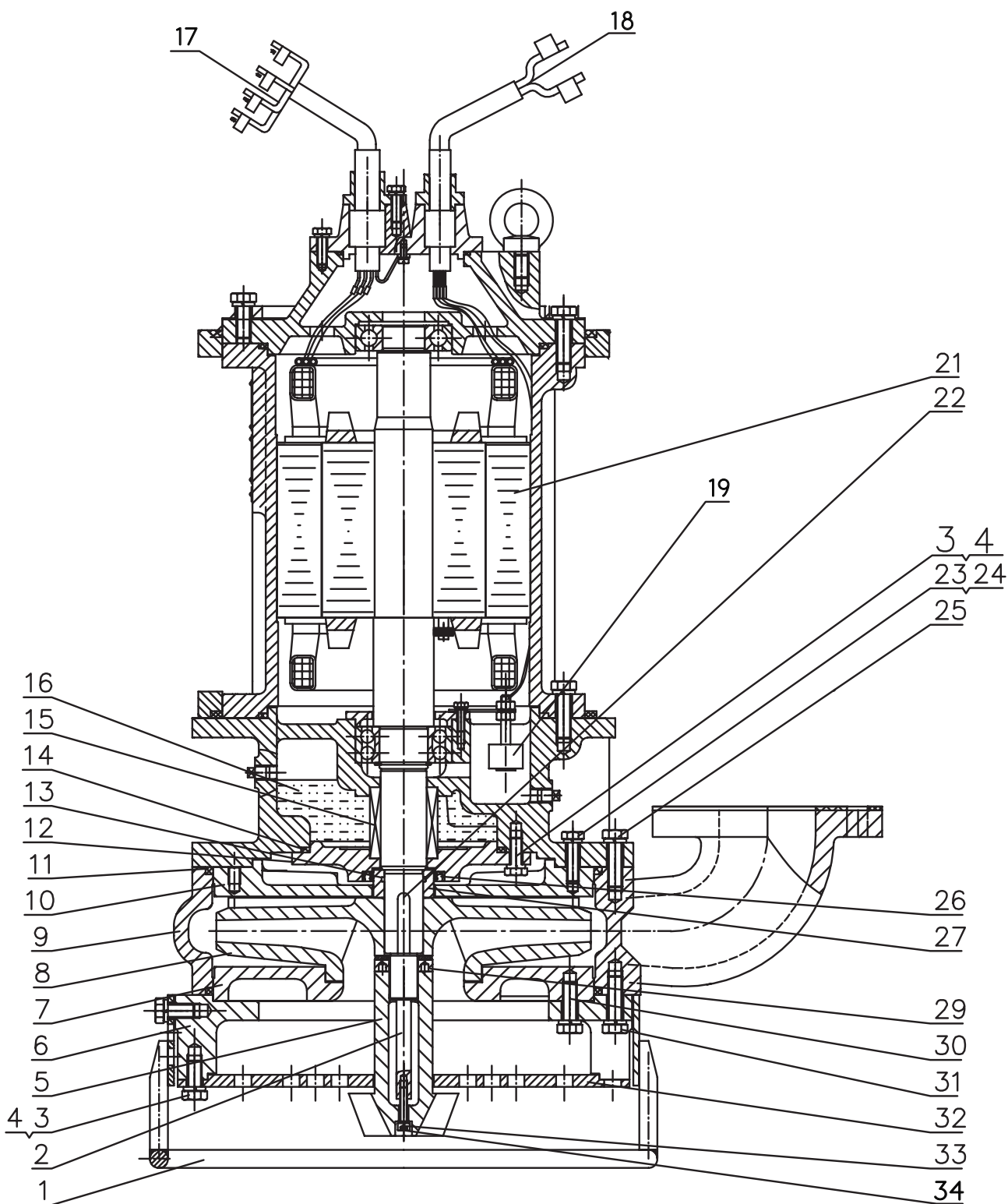

## Operating, Installation and Maintenance

## Model 80ENZX67.54

## Sectional View - Parts Reference

Item No.	Part Description	Part Number	QTY for 1 pump	Material
1	Stand	ENZX10019	1	304 Stainless Steel
2	Threaded Shaft Extension	ENZX10001	1	304 Stainless Steel
3	Bolt M12X25	-	16	304 Stainless Steel
4	Washer 12	-	34	304 Stainless Steel
5	Agitator	ENZX10002	1	High Chrome Iron
6	Suction Frame	ENZX10005	1	Cast Iron
7	Suction Liner	ENZX10006	1	High Chrome Iron
8	Impeller	ENZX10008	1	High Chrome Iron
9	Pump Casing	ENZX10007	1	High Chrome Iron
10	Upper Liner	ENZX10010	1	High Chrome Iron
11	O-Ring	ENZX10013*	2	Buna
12	Lower Mech Seal Chamber Cover	ENZX10026	1	Cast Iron
13	O-Ring	ENZX10013*	1	Buna
14	O-Ring	ENZX10013*	1	Buna
15	Mechanical Seal	ENZX10012	1	-
16	L-TSA 32# Turbine Oil	-	-	-
17	Power Cable	ENZX10016	1	-
18	Control Cable	ENZX10017	1	-
19	Leakage Detector	ENZX10018	1	-
21	Motor Assembly	-	1	Cast Iron
22	Key C10X50	ENZX10020	1	304 Stainless Steel
23	Bolt M10X35	-	8	304 Stainless Steel
24	Washer 10	-	8	304 Stainless Steel
25	Bolt M12X40	-	6	304 Stainless Steel
26	Lip Seal	ENZX10014	1	-
27	Wear Bushing	ENZX10015	1	304 Stainless Steel
29	Impeller Nut	ENZX10009	1	304 Stainless Steel
30	Bolt M12X35	-	6	304 Stainless Steel
31	Bolt M12X45	-	6	304 Stainless Steel
32	Strainer	ENZX10022	1	304 Stainless Steel
33	Screw M6X30	ENZX10027**	1	304 Stainless Steel
34	Washer 6	ENZX10027**	1	304 Stainless Steel

\* O-Ring Kit

\*\* Agitator Bolt Kit



**Model 80ENZX6114**

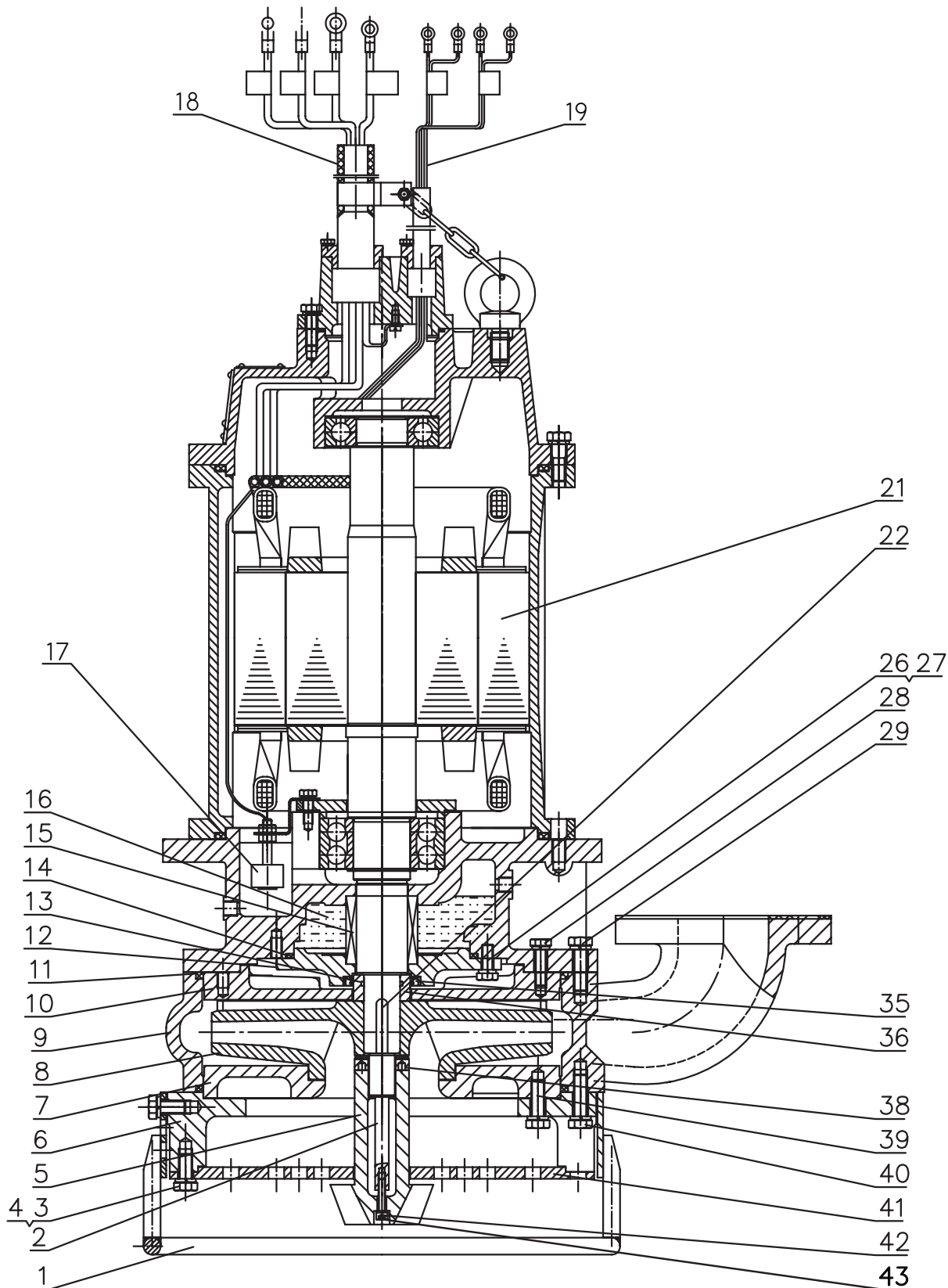

## Operating, Installation and Maintenance

## Model 80ENZX6114

## Sectional View - Parts Reference

Item No.	Part Description	Part Number	QTY for 1 pump	Material
1	Stand	ENZX15019	1	304 Stainless Steel
2	Threaded Shaft Extension	ENZX15001	1	304 Stainless Steel
3	Bolt M12X25	-	8	304 Stainless Steel
4	Washer 12	-	26	304 Stainless Steel
5	Agitator	ENZX15002	1	High Chrome Iron
6	Suction Frame	ENZX15005	1	Cast Iron
7	Suction Liner	ENZX15006	1	High Chrome Iron
8	Impeller	ENZX15008	1	High Chrome Iron
9	Pump Casing	ENZX15007	1	High Chrome Iron
10	Upper Liner	ENZX15010	1	High Chrome Iron
11	O-Ring	ENZX15013*	2	Buna
12	Lower Mech Seal Chamber Cover	ENZX15026	1	Cast Iron
13	O-Ring	ENZX15013*	1	Buna
14	O-Ring	ENZX15013*	1	Buna
15	Mechanical Seal	ENZX15012	1	-
16	L-TSA 32# Turbine Oil	-	-	-
17	Leakage Detector	ENZX15018	1	-
18	Power Cable	ENZX15016	1	-
19	Control Cable	ENZX15017	1	-
21	Motor Assembly	-	1	Cast Iron
22	Key C10X50	ENZX15020	1	304 Stainless Steel
26	Bolt M10X25	-	8	304 Stainless Steel
27	Washer 10	-	16	304 Stainless Steel
28	Bolt M10X35	-	8	304 Stainless Steel
29	Bolt M10X40	-	6	304 Stainless Steel
35	Lip Seal	ENZX15014	1	-
36	Wear Bushing	ENZX15015	1	304 Stainless Steel
38	Impeller Nut	ENZX15009	1	304 Stainless Steel
39	Bolt M12X35	-	6	304 Stainless Steel
40	Bolt M12X45	-	6	304 Stainless Steel
41	Strainer	ENZX15022	1	304 Stainless Steel
42	Screw M6X30	ENZX15027**	1	304 Stainless Steel
43	Washer 6	ENZX15027**	1	304 Stainless Steel

\* O-Ring Kit

\*\* Agitator Bolt Kit



**Model 80ENZX6154 – Two-Stage Model**

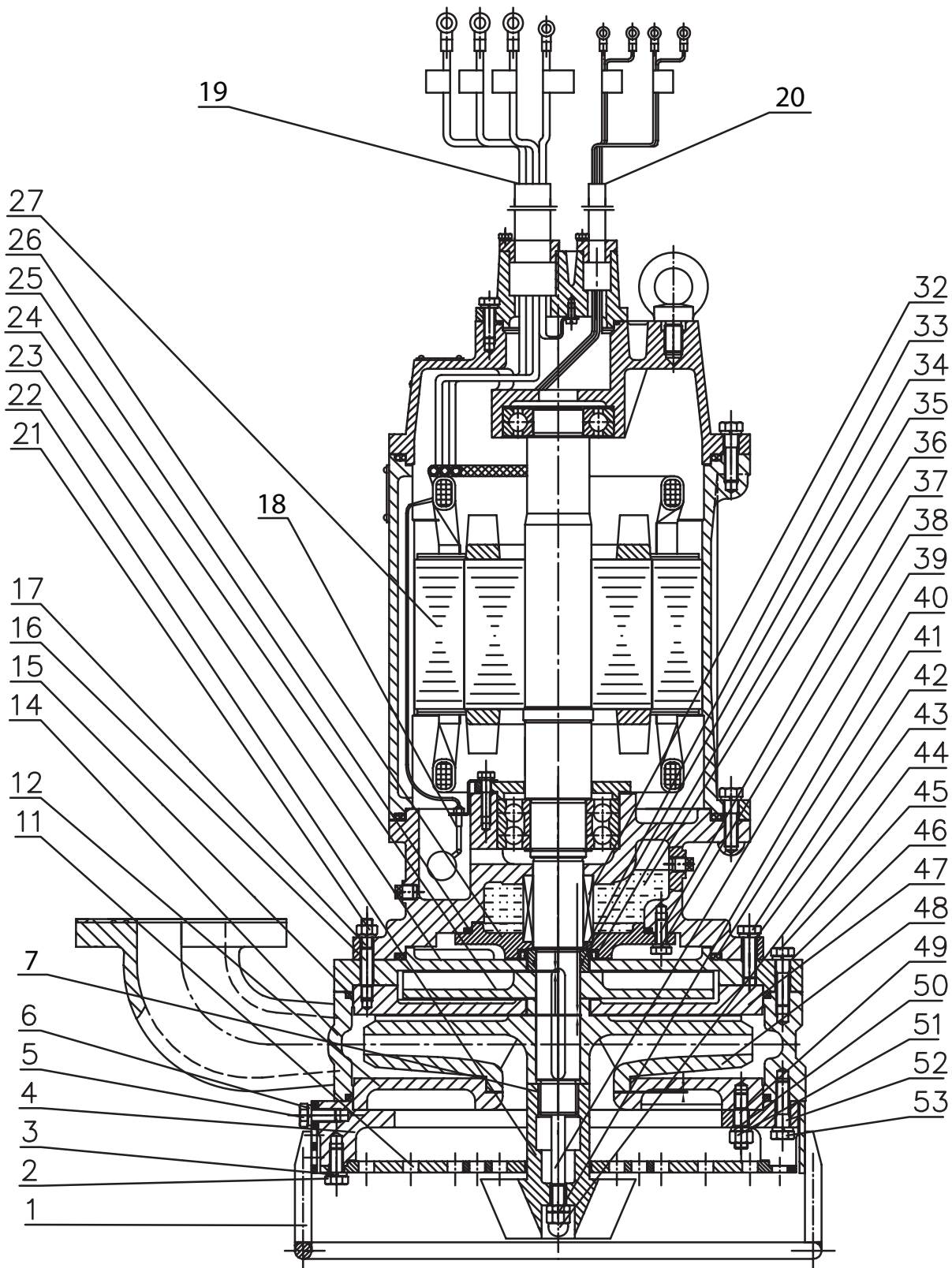

## Operating, Installation and Maintenance

Model 80ENZX6154 – Two-Stage Model  
Sectional View - Parts Reference

Item No.	Part Description	Part Number	QTY for 1 pump	Material
1	Stand	ENZX20019	1	304 Stainless Steel
2	Bolt M12X25	-	4	304 Stainless Steel
3	Washer 12	-	4	304 Stainless Steel
4	Suction Frame	ENZX20005	1	Cast Iron
5	Bolt M12X25	-	4	304 Stainless Steel
6	Washer 12	-	4	304 Stainless Steel
7	Impeller Nut	ENZX20009	1	304 Stainless Steel
11	Strainer	ENZX20022	1	304 Stainless Steel
12	Suction Liner	ENZX20006	1	High Chrome Iron
14	Pump Casing	ENZX20007	1	High Chrome Iron
15	O-Ring	ENZX20013*	2	Buna
16	Bolt M10X60	-	6	304 Stainless Steel
17	Washer 10	-	6	304 Stainless Steel
18	Leakage Detector	ENZX20018	1	-
19	Power Cable	ENZX20016	1	-
20	Control Cable	ENZX20017	1	-
21	Nut M10	-	2	304 Stainless Steel
22	Agitator	ENZX20002	1	High Chrome Iron
23	Back Liner	ENZX20023	1	High Chrome Iron
24	Assistant Impeller	ENZX20011	1	High Chrome Iron
25	O-Ring	ENZX20013*	1	Buna
26	Lower Mech Seal Chamber Cover	ENZX20026	1	Cast Iron
27	Motor Assembly	-	1	Cast Iron
32	Mechanical Seal	ENZX20012	1	
33	Wear Bushing	ENZX20015	1	304 Stainless Steel
34	O-Ring	ENZX20013*	1	Buna
35	Lip Seal	ENZX20014	1	-
36	L-TSA 32# Turbine Oil	-	-	-
37	Washer 10	-	8	304 Stainless Steel
38	Bolt M10X25	-	8	304 Stainless Steel
39	Threaded Shaft Extension	ENZX20001	1	304 Stainless Steel
40	Nut M12	ENZX20027**	1	304 Stainless Steel
41	O-Ring	ENZX20013*	1	Buna
42	Bolt M12X40	-	6	304 Stainless Steel
43	Washer 12	-	6	304 Stainless Steel
44	Nut M12	ENZX20027**	1	304 Stainless Steel
45	Bolt M12X45	-	6	304 Stainless Steel
46	Washer 12	-	6	304 Stainless Steel
47	Upper Liner	ENZX20010	1	High Chrome Iron
48	Impeller	ENZX20008	1	High Chrome Iron
49	Bolt A M12X35	-	6	304 Stainless Steel
50	Washer 12	-	6	304 Stainless Steel
51	Nut M12	-	6	304 Stainless Steel
52	Washer 12	-	6	304 Stainless Steel
53	Bolt M12X45	-	6	304 Stainless Steel

\* O-Ring Kit

\*\* Agitator Bolt Kit





**Model 100ENZXA6154**

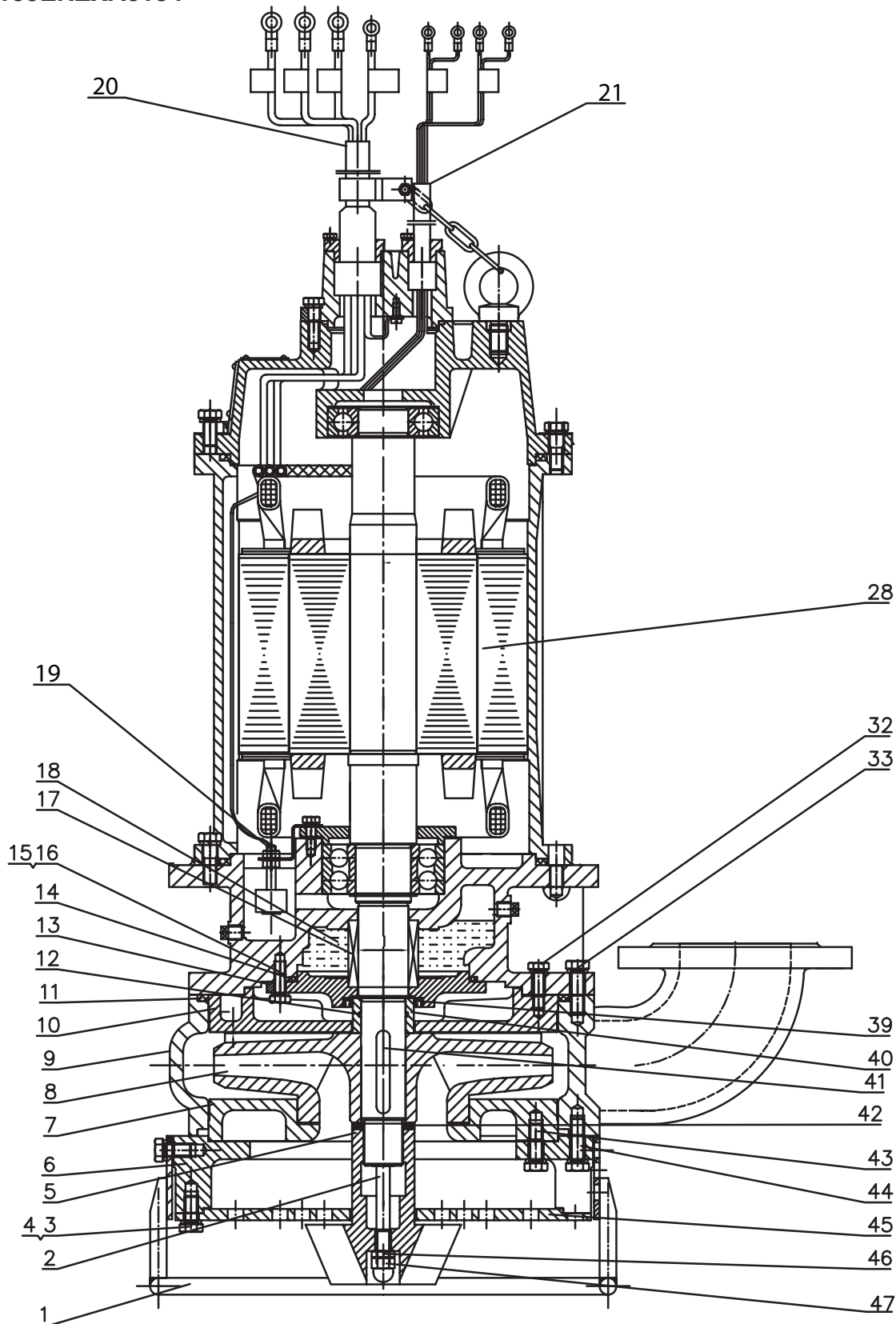



## Operating, Installation and Maintenance

## Model 100ENZXA6154

## Sectional View - Parts Reference

Item No.	Part Description	Part Number	QTY for 1 pump	Material
1	Stand	ENZXA20019	1	304 Stainless Steel
2	Threaded Shaft Extension	ENZXA20001	1	304 Stainless Steel
3	Bolt M12X25	-	8	304 Stainless Steel
4	Washer 12	-	32	304 Stainless Steel
5	Agitator	ENZXA20002	1	High Chrome Iron
6	Suction Frame	ENZXA20005	1	Cast Iron
7	Suction Liner	ENZXA20006	1	High Chrome Iron
8	Impeller	ENZXA20008	1	High Chrome Iron
9	Pump Casing	ENZXA20007	1	High Chrome Iron
10	Upper Liner	ENZXA20010	1	High Chrome Iron
11	O-Ring	ENZXA20013*	2	Buna
12	O-Ring	ENZXA20013*	1	Buna
13	Lower Mech Seal Chamber Cover	ENZXA20026	1	Cast Iron
14	O-Ring	ENZXA20013*	1	Buna
15	Washer 10	-	16	304 Stainless Steel
16	Bolt M10X25	-	8	304 Stainless Steel
17	Mechanical Seal	ENZXA20012	1	-
18	L-TSA 32# Turbine Oil	-	-	-
19	Leakage Detector	ENZXA20018	1	-
20	Power Cable	ENZXA20016	1	-
21	Control Cable	ENZXA20017	1	-
28	Motor Assembly	-	1	Cast Iron
32	Bolt M10X35	-	8	304 Stainless Steel
33	Bolt M12X40	-	6	304 Stainless Steel
39	Lip Seal	ENZXA20014	1	-
40	Wear Bushing	ENZXA20015	1	304 Stainless Steel
41	Key C12X75	ENZXA20020	1	304 Stainless Steel
42	Impeller Nut	ENZXA20009	1	Carbon Steel
43	Bolt M12X35	-	6	304 Stainless Steel
44	Bolt M12X45	-	6	304 Stainless Steel
45	Strainer	ENZXA20022	1	304 Stainless Steel
46	Nut M12	ENZXA20027**	1	304 Stainless Steel
47	Nut M12	ENZXA20027**	1	304 Stainless Steel

\* O-Ring Kit

\*\* Agitator Bolt Kit



**Model 100ENZXB6154**

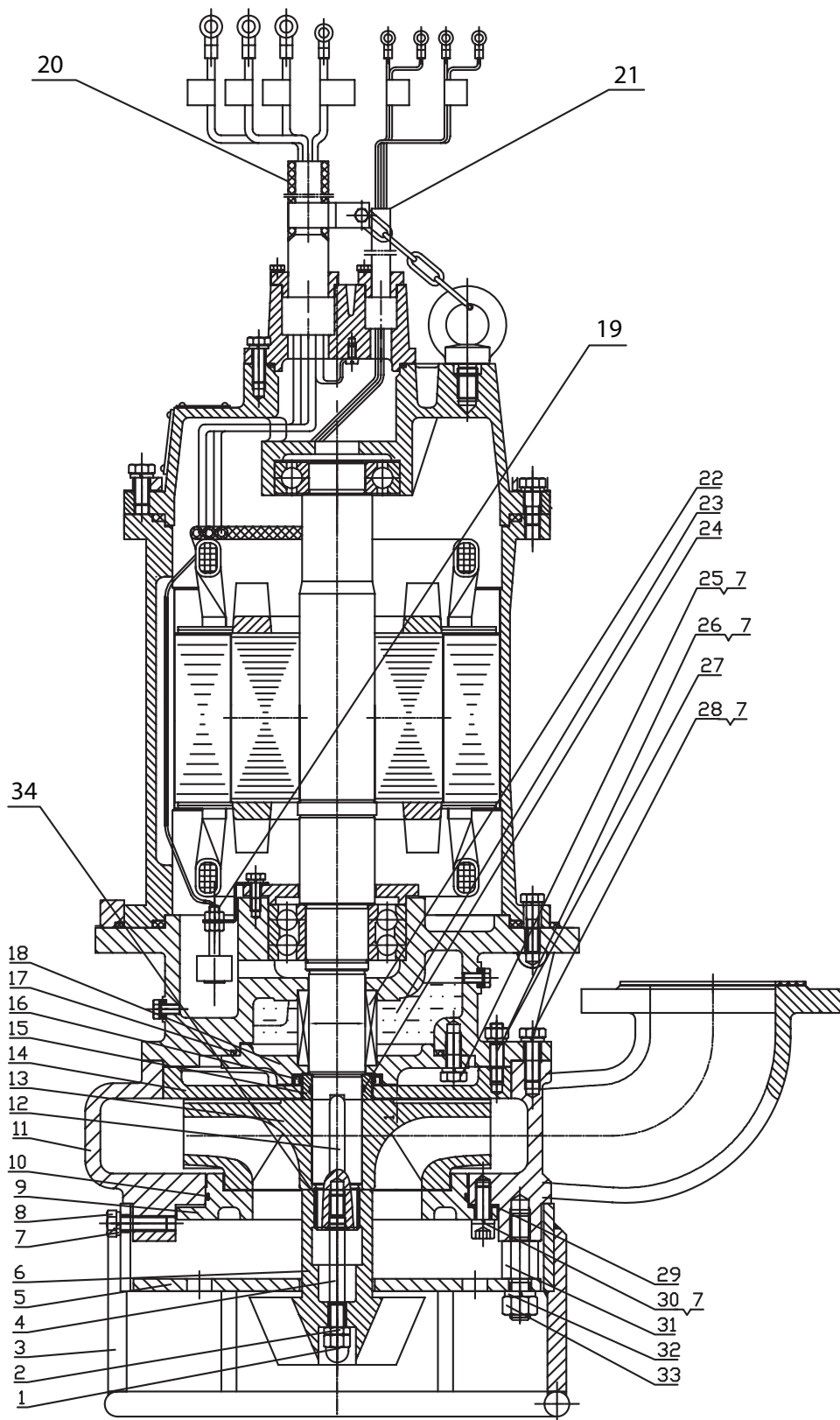

## Operating, Installation and Maintenance

## Model 100ENZXB6154

## Sectional View - Parts Reference

Item No.	Part Description	Part Number	QTY for 1 pump	Material
1	Nut M12	ENZXB20027**	1	304 Stainless Steel
2	Nut M12	ENZXB20027**	1	304 Stainless Steel
3	Stand	ENZXB20019	1	304 Stainless Steel
4	Threaded Shaft Extension	ENZXB20001	1	304 Stainless Steel
5	Strainer	ENZXB20022	1	304 Stainless Steel
6	Agitator	ENZXB20002	1	High Chrome Iron
7	Washer 12	-	27	304 Stainless Steel
8	Bolt M12X30	-	4	304 Stainless Steel
9	Suction Liner	ENZXB20006	1	High Chrome Iron
10	O-Ring	ENZXB20013*	1	Buna
11	Pump Casing	ENZXB20007	1	High Chrome Iron
12	Key 12X40	ENZXB20020	1	304 Stainless Steel
13	Impeller	ENZXB20008	1	High Chrome Iron
14	Upper Liner	ENZXB20010	1	High Chrome Iron
15	Wear Bushing	ENZXB20015	1	304 Stainless Steel
16	Lip Seal	ENZXB20014	1	-
17	O-Ring	ENZXB20013*	1	Buna
18	Lower Mech Seal Chamber Cover	ENZXB20026	1	Cast Iron
19	Leakage Detector	ENZXB20018	1	-
20	Power Cable	ENZXB20016	1	-
21	Control Cable	ENZXB20017	1	-
22	Mechanical Seal	ENZXB20012	1	-
23	L-TSA 32# Turbine Oil	-	-	-
24	O-Ring	ENZXB20013*	1	Buna
25	Bolt M12X25	-	8	304 Stainless Steel
26	Nut M10	-	3	304 Stainless Steel
27	Bolt A M10X35	-	3	304 Stainless Steel
28	Bolt M12X35	-	6	304 Stainless Steel
29	Adjustment Washer	ENZXB20021	-	Brass
30	Screw M12X30	-	6	304 Stainless Steel
31	Fix Bolt	-	4	304 Stainless Steel
32	Washer 16	-	4	304 Stainless Steel
33	Nut M15	-	4	304 Stainless Steel
34	Impeller Nut	ENZXB20009	1	304 Stainless Steel

\* O-Ring Kit

\*\* Agitator Bolt Kit



**Model 100ENZXC6154**

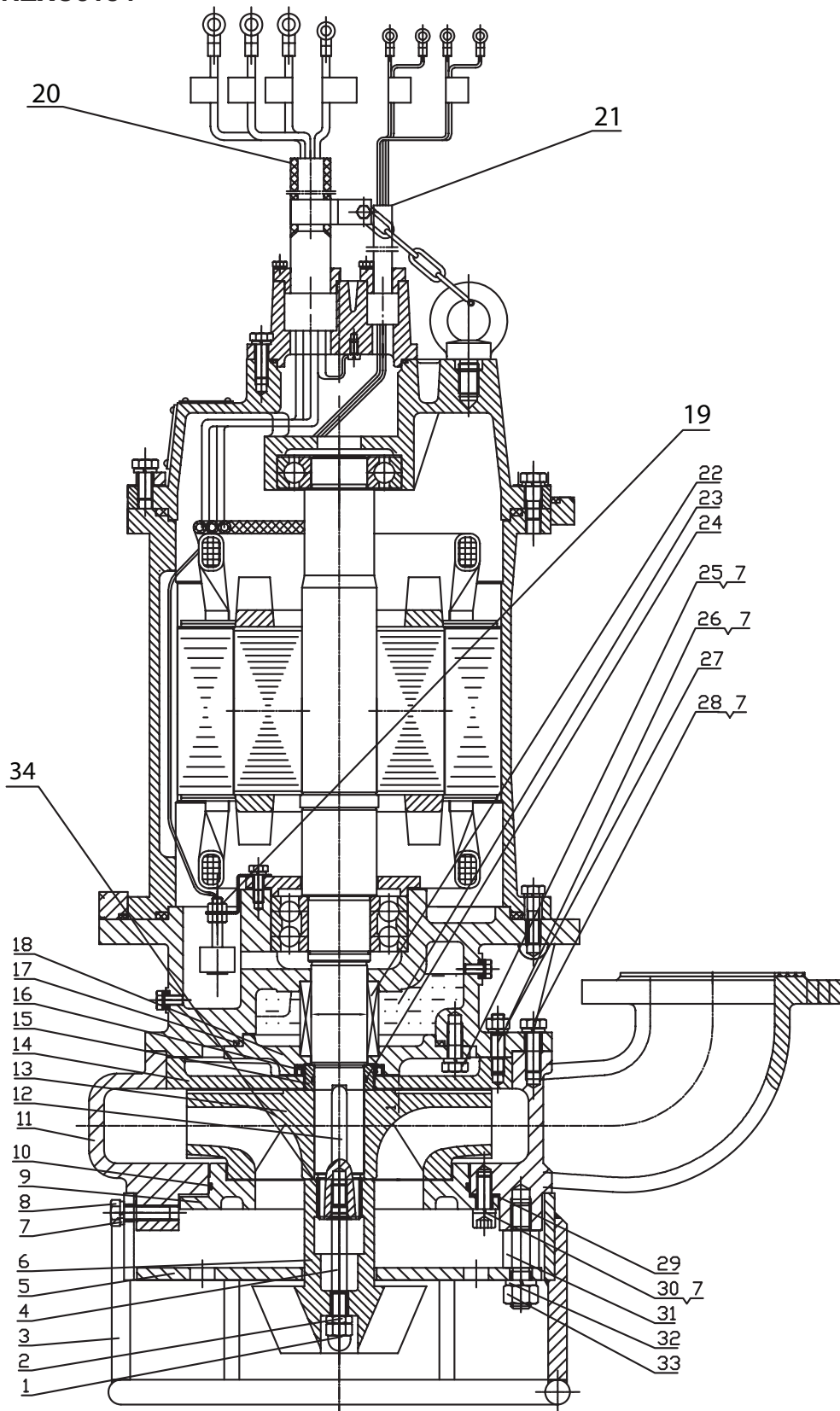

## Operating, Installation and Maintenance

## Model 100ENZXC6154

## Sectional View - Parts Reference

Item No.	Part Description	Part Number	QTY for 1 pump	Material
1	Nut M12	ENZXC20027**	1	304 Stainless Steel
2	Nut M12	ENZXC20027**	1	304 Stainless Steel
3	Stand	ENZXC20019	1	304 Stainless Steel
4	Threaded Shaft Extension	ENZXC20001	1	304 Stainless Steel
5	Strainer	ENZXC20022	1	304 Stainless Steel
6	Agitator	ENZXC20002	1	High Chrome Iron
7	Washer 12	-	27	304 Stainless Steel
8	Bolt M12X30	-	4	304 Stainless Steel
9	Suction Liner	ENZXC20006	1	High Chrome Iron
10	O-Ring	ENZXC20013*	1	Buna
11	Pump Casing	ENZXC20007	1	High Chrome Iron
12	Key 12X40	ENZXC20020	1	304 Stainless Steel
13	Impeller	ENZXC20008	1	High Chrome Iron
14	Upper Liner	ENZXC20010	1	High Chrome Iron
15	Wear Bushing	ENZXC20015	1	304 Stainless Steel
16	Lip Seal	ENZXC20014	1	-
17	O-Ring	ENZXC20013*	1	Buna
18	Lower Mech Seal Chamber Cover	ENZXC20026	1	Cast Iron
19	Leakage Detector	ENZXC20018	1	-
20	Power Cable	ENZXC20016	1	-
21	Control Cable	ENZXC20017	1	-
22	Mechanical Seal	ENZXC20012	1	-
23	L-TSA 32# Turbine Oil	-	-	-
24	O-Ring	ENZXC20013*	1	Buna
25	Bolt M12X25	-	8	304 Stainless Steel
26	Nut M10	-	3	304 Stainless Steel
27	Bolt A M10X35	-	3	304 Stainless Steel
28	Bolt M12X35	-	6	304 Stainless Steel
29	Adjustment Washer	ENZXC20021	-	Brass
30	Screw M12X30	-	6	304 Stainless Steel
31	Fix Bolt	-	4	304 Stainless Steel
32	Washer 16	-	4	304 Stainless Steel
33	Nut M15	-	4	304 Stainless Steel
34	Impeller Nut	ENZXC20009	1	304 Stainless Steel

\* O-Ring Kit

\*\* Agitator Bolt Kit



**Model 150ENZX6224**

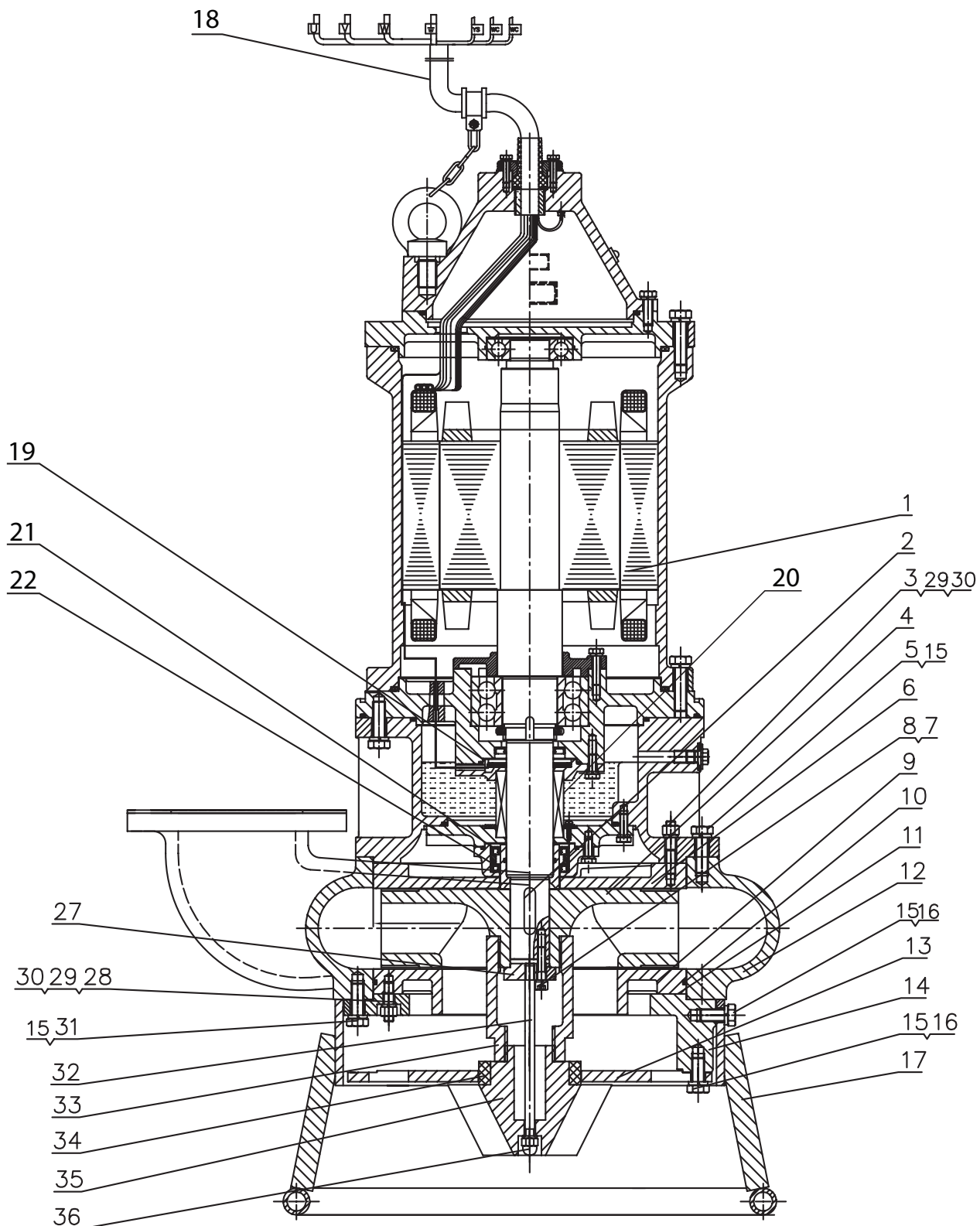

## Operating, Installation and Maintenance

## Model 150ENZX6224

## Sectional View - Parts Reference

Item No.	Part Description	Part Number	QTY for 1 pump	Material
1	Motor Assembly	-	1	Cast Iron
2	Key 14X60	ENZX30020	1	304 Stainless Steel
3	Bolt A M12X50	-	6	304 Stainless Steel
4	Impeller	ENZX30008	1	High Chrome Iron
5	Bolt M16X50	-	6	304 Stainless Steel
6	Upper Liner	ENZX30010	1	High Chrome Iron
7	Washer 10	-	4	304 Stainless Steel
8	Screw M10X45	-	4	304 Stainless Steel
9	Suction Liner	ENZX30006	1	High Chrome Iron
10	O-Ring	ENZX30013	1	Buna
11	Adjustment Washer	ENZX30021	-	Brass
12	Pump Casing	ENZX30007	1	High Chrome Iron
13	Strainer	ENZX30022	1	304 Stainless Steel
14	Suction Frame	ENZX30005	1	Cast Iron
15	Washer 16	-	20	304 Stainless Steel
16	Bolt M16X35	-	8	304 Stainless Steel
17	Stand	ENZX30019	1	304 Stainless Steel
18	Power Cable	ENZX30016	1	-
19	Leakage Detector	ENZX30018	1	-
20	Mechanical Seal	ENZX30012	1	-
21	Lip Seal	ENZX30014	1	-
22	Wear Bushing	ENZX30015	1	304 Stainless Steel
27	Impeller Nut	ENZX30009	1	Carbon Steel
28	Bolt A M12X35	-	6	304 Stainless Steel
29	Washer 12	-	15	304 Stainless Steel
30	Nut M12	-	15	304 Stainless Steel
31	Bolt M16X45	-	6	304 Stainless Steel
32	Threaded Shaft Extension	ENZX30001	1	304 Stainless Steel
33	Hub	ENZX30004	1	High Chrome Iron
34	Rubber Bushing	ENZX30003	1	Rubber
35	Agitator	ENZX30002	1	High Chrome Iron
36	Nut M12	ENZX30027	1	304 Stainless Steel



**Operating, Installation and Maintenance****Warranty – All specifications subject to change without notice.**

**Ebara International Corporation**  
1651 Cedar Line Drive  
Rock Hill, SC 29730

**STANDARD CONDITIONS OF SALE**

These STANDARD CONDITIONS OF SALE (“Conditions”) exclusively define the contractual relationship between EBARA INTERNATIONAL CORPORATION (“EIC”) and the Purchaser, and no terms proposed by the Purchaser in conflict with or additional to these Conditions shall become a part of the contract of sale unless expressly accepted in writing by EIC. Any EIC proposal to which these Conditions are attached shall be for information purposes only, and Purchaser’s order is subject to acceptance and acknowledgment by EIC as the supplier of the equipment ordered in accordance with these conditions.

**TERMS OF PAYMENT**

Terms of Payment for any order based on these Conditions shall be included in the EIC Proposal of which these Conditions are a part.

**PRICE ADJUSTMENT**

The price clauses applicable to the contract of sale of which these Conditions are a part are included in the EIC Proposal and are based on the proposed shipping date of the equipment cited. In the event of delays in release to manufacture or in shipment for any reason, the contract price shall be adjusted to the price in effect at the time of shipment. Some equipment to be provided hereunder which is not manufactured by EIC (“Other Equipment”) may be subject to different pricing adjustment policies than those stated for the EIC-manufactured equipment (“EIC Products”), which Other Equipment shall be identified in the Proposal of which these Conditions are a part and which shall be incorporated in the contract.

**I. WARRANTY, REMEDY, DISCLAIMER**

EIC warrants for a period of twelve months from the date of initial startup or eighteen months from the date of shipment, whichever shall first occur (the “Warranty Period”) the EIC Products to be delivered hereunder against defects in material and workmanship, under normal use and service when installed, used and maintained in accordance with instructions supplied by EIC. This is EIC’s sole and exclusive warranty. It applies only to EIC Products and specifically excludes Other Equipment, whether or not such Other Equipment is included in EIC’s scope of supply hereunder. Such Other Equipment is warranted only by its manufacturer. If such a defect appears in EIC Products within the Warranty Period and Purchaser has given EIC immediate written notice of same, EIC will either repair the part, or at its option replace the part, by shipping a similar part F.O.B. EIC’s shipping point, or at its option refund an equitable portion of the purchase price. EIC may require the return of the defective part, transportation prepaid, to establish the claim. All costs of removal, reinstallation, field labor and transportation shall be borne by the Purchaser. No allowance will be made for repairs without EIC’s written consent or approval, and the Warranty Period shall not be suspended upon stopping operation for warranty repairs, nor recommence upon completion of the warranty repairs, but shall run continuously from commencement until normal expiration. Repair parts shall carry no greater warranty than the remaining balance of the underlying EIC Product into which they may be installed, expiring at the same time as said underlying warranty.

Any descriptions of the EIC Products or Other Equipment, any specifications, and any samples, models, bulletins, or similar material used in connection with this sale are for the sole purpose of identifying the said Equipment and are not to be construed as express or implied warranties. Unless during the warranty period all repairs or replacements or parts or components for EIC Products are with EIC-approved parts or components, and all warranty service is performed by EIC or its authorized distributor or representative, the warranty responsibility of EIC shall immediately terminate.

EIC MAKES NO OTHER WARRANTY OF ANY KIND WHATSOEVER, EXPRESS OR IMPLIED; AND ALL WARRANTIES OF MERCHANTABILITY AND FITNESS FOR A PARTICULAR PURPOSE ARE HEREBY DISCLAIMED BY EIC AND EXCLUDED FROM THESE CONDITIONS. The Purchaser’s sole and exclusive remedy, whether upon warranty, contract or tort, including negligence, will be to proceed under this warranty. All liability of EIC shall terminate no later than the expiration of the Warranty Period.

\_N.B.: If the Equipment being sold hereunder is designated “Municipal: Permanent Installations,” there is attached hereto, incorporated by reference herein and made a part hereof, as Attachment A., EIC’s “5 Year (10,000 Hour) Pump Warranty” (hereinafter, “Municipal Warranty”). Said Municipal Warranty replaces and supersedes in its entirety this Warranty, Remedy, Disclaimer Paragraph I. All other terms and conditions of these STANDARD TERMS AND CONDITIONS OF SALE remain unchanged.

**II. INSPECTIONS, TESTS**

Any Purchaser inspections or shop testing of EIC Product at EIC’s facilities prior to its shipment must be authorized by EIC in writing at least ten (10) days prior to such inspection, and shall be subject to EIC’s manufacturing cycle availability and facility security requirements. Field testing of EIC Products may be conducted by Purchaser to confirm mechanical compatibility of the EIC Product and that there has been no damage in transit, but compliance with specifications shall be conclusively established by shop tests at EIC’s facilities.

**III. LIMITATION OF LIABILITY**

EIC shall not in any event be liable for special, indirect, incidental or consequential damages, including liquidated damages in any amount. EIC’s liability on any claim of any kind, including negligence, for any loss or damage arising out of, connected with, or resulting from a contract based on these Conditions, or the performance or breach thereof, or the design, manufacturer, sale, delivery, resale, installation, technical direction of installation, inspection, repair, operation or use of any EIC Products covered by or furnished hereunder shall in no case exceed the price paid by the Purchaser for the Equipment. EIC also disclaims liability, whether in contract, tort, warranty or otherwise, to any party other than Purchaser, and EIC’s sole responsibilities with respect to Other Equipment furnished hereunder shall be to ensure mechanical compatibility of EIC Equipment with the Other Equipment and to pass through to the Purchaser whatever warranty the Other Equipment manufacturer has provided to EIC.



**Operating, Installation and Maintenance**

---

**Warranty – continued****IV. SHIPPING DATES/FORCE MAJEURE**

The time for shipment given herein is approximate and is estimated from the date of receipt of order with complete manufacturing information and approval of drawings as may be necessary. EIC shall not be liable for any loss or damage for delay or non-delivery due to the acts of civil or military authority, acts of the Purchaser or by reason of “force majeure”, which shall be deemed to mean all causes whatsoever not reasonably within the control of EIC, including, but not limited to, acts of God, war, riot or insurrection, blockades, embargoes, sabotage, epidemics, fires, strikes, lockouts or other industrial disturbances, delays of carriers and inability to secure materials, labor or manufacturing facilities.

**V. PAYMENTS**

The prices quoted herein are specified in U.S. Dollars and shall be payable to EIC free of all exchange, conversion and collection fees or charges. Pro rata payments shall be made for partial shipments. If shipment is temporarily suspended or postponed at the Purchaser’s request, or prevented per paragraph IV., above, then all dates of payment based on date of shipment shall relate instead to the date of completion of manufacture. Letters of credit or other credit instruments established for the Equipment specified herein shall provide for such payment on completion of manufacture where shipment is prevented or postponed under such circumstances. In the event delay in shipment is requested by Purchaser, all costs and risk of storage and reinspection to make Equipment ready for shipment shall be borne by Purchaser. When in the opinion of EIC the financial condition of the Purchaser renders it prudent, EIC may require cash payment or satisfactory security before shipment. Interest at the highest legal rate permitted, not to exceed one and one-half (1 1/2%) percent per month, will apply to all invoices not paid when due.

**VI. CHANGES AND DRAWINGS**

EIC reserves the right to change or modify the design and construction of Equipment and to substitute materials of construction. Such changes, modifications or substitutions, however, shall not affect EIC’s commitment to Purchaser to provide Equipment in accordance with specifications as accepted by EIC. If drawings are furnished, they are submitted to show general style and arrangement of the Equipment offered.

**VII. CANCELLATION, SUSPENSION, TERMINATION FOR CONVENIENCE OF PURCHASER**

The Purchaser may terminate this order for the convenience of the Purchaser at any time upon written notice and payment to EIC of cancellation charges as shall be specified by EBARA, which charges may include reasonable anticipated profits and unabsorbed burden costs for EIC. EIC shall use its best efforts to mitigate these latter costs to Purchaser, but shall be under no obligation to act to its overall detriment thereby.

If EIC’s performance of the work is delayed for a period of more than three (3) months either by reason of the request or acts of the Purchaser, acts of civil or military authority or by “force majeure,” upon removal of the cause of any such delay EBARA’s performance shall be resumed, delivery will be rescheduled, and the purchase price shall be adjusted to that in effect at the time of resumption of performance, as may then be notified by EIC to Purchaser. If Purchaser is unwilling to accept the adjustment price and/or projected delivery date, he may cancel his order by giving written notice thereof to EIC within ten (10) days after EIC’s notification. In such event, Purchaser shall be liable for payment of reasonable cancellation charges as specified by EIC, but such charges shall be equitably determined, based on the reason for such termination and EIC’s reasonable ability to reutilize such terminated Equipment. In no event shall EIC be liable hereunder for cover or other consequential damages.

**VIII. RISK OF LOSS, SECURITY**

The Purchaser shall bear all risk of loss of or damage to the Equipment after delivery to EIC’s transportation facility at shipping point. Purchaser agrees that EIC shall retain a security interest in the Equipment only until the purchase price has been paid, and Purchaser agrees to perform all acts necessary and/or require to perfect and assure EIC’s security interest.

**IX. TAXES, DUTIES, FREIGHT**

The Purchaser shall pay to EIC, in addition to the purchase price, the amount of all Customs duties, fees and charges, Sales, Use, Privilege, Occupation, Excise or other taxes, Federal, state, local, or foreign, which EIC may be required to pay in connection with furnishing Equipment or services to the Purchaser. Purchaser shall also be responsible for payment of all transportation charges, including such increases in cost as may be imposed from rate changes between the time of quotation and shipment, and any additional costs required by changes in Purchaser’s shipping requirements.

**X. DISPUTES**

The parties shall use their best efforts to resolve any disputes amicably, in realization that costs associated with litigation of differences may be disproportionate to the matter in dispute. Should amicable resolution prove unsuccessful, the parties hereby consent to the jurisdiction of the Nevada Courts and the application of Nevada laws, rules and regulations in adjudication of any such dispute. By mutual agreement the parties may elect to submit any dispute to binding arbitration in lieu of litigation, in which event such arbitration shall be conducted in Reno or Carson City, Nevada before the American Arbitration Association in accordance with its Rules of Conciliation and Arbitration and applying the laws of the State of Nevada. Each party shall bear its own costs of arbitration.

**XI. MISCELLANEOUS**

In the event any of the Conditions herein is determined to be legally unenforceable, such Condition shall be deemed severed from these Conditions, and the balance shall remain in full force and effect. In the event, however, that such severing materially alters the nature of the relationship between the parties hereto, then at the option of EIC the contract of sale of which these Conditions are a part may be terminated for the convenience of EIC, and an equitable adjustment shall be made for any funds previously paid by Purchaser for which Equipment has not yet been shipped.

These Conditions constitute the entire agreement relating to Conditions of Sale between the parties hereto, and all previous negotiations, discussions and agreements are deemed merged into and superseded by these Conditions.



*Contact your dealer or supplier  
for more information about other EBARA products.*

*All specifications subject to technical alterations.*



**EBARA Fluid Handling**

1651 Cedar Line Drive • Rock Hill, SC 29730

(803) 327-5005 (t) • (803) 327-5097 (f)

[www.pumpsebara.com](http://www.pumpsebara.com)

© 2013 EBARA International Corporation

EFH\_ENZX 0314