

## Shorten lead times and minimize downtime with our cost-effective, single-cartridge seal design

Keep industrial pumping systems running with the KeyPS seal, readily available globally from Flowserve. Pre-engineered to be quickly shipped to minimize downtime, the KeyPS seal is a single-pusher design for general industrial applications.

Options for popular standard and large bore ASME, DIN and ISO pumps are in stock with short lead times and supported by the worldwide network of Flowserve manufacturing facilities and Quick Response Centers.

The cartridge design of the KeyPS seal provides a low-risk upgrade from packing or component seals; it also cost-effectively meets higher equipment reliability expectations. A standard flush port facilitates clean and cool seal face operation when connected to an inner seal piping plan.

### Customer benefits

- **Save time** with a quick installation and ensure startup success with a cartridge seal design that requires no extra measurements or settings.
- **Minimize spare parts inventory** and standardize seals across a facility owing to robust materials which are suitable for a wide range of applications, industries and fluid environments.
- **Provide uninterrupted operation** in dirty applications as a result of its springs being isolated from the process fluid to prevent clogging and hang-up.
- **Extend wear life** because its balanced seal faces are immersed in the process fluid so they can inherently run cooler than shrouded and unbalanced seals.
- **Ensure low-leakage operation** and environmental safety with its O-ring pusher design, which employs multiple coil springs to maintain proper seal face tracking.

### General industries

- Agriculture
- Biofuel and renewables
- Building and construction
- Corn wet milling and ethanol
- Food and beverage
- Marine
- Mining
- Pulp and paper
- Specialty chemicals
- Steel and primary metals
- Textiles
- Water and wastewater



### Materials of construction

- **Metal components** 316 stainless steel
- **Seal faces** Carbon, silicon carbide
- **Gaskets** FKM, FEPM
- **Springs** Alloy C-276

### Operating parameters

- **Pressure** 16.55 bar (240psi)
- **Temperature** -40°C to 121°C (-40°F to 250°F)
- **Speed** to 3,600 rpm
- **Shaft size** 33 to 70 mm (1.125 to 2.750 in.)

### Available sizes for standard pumps

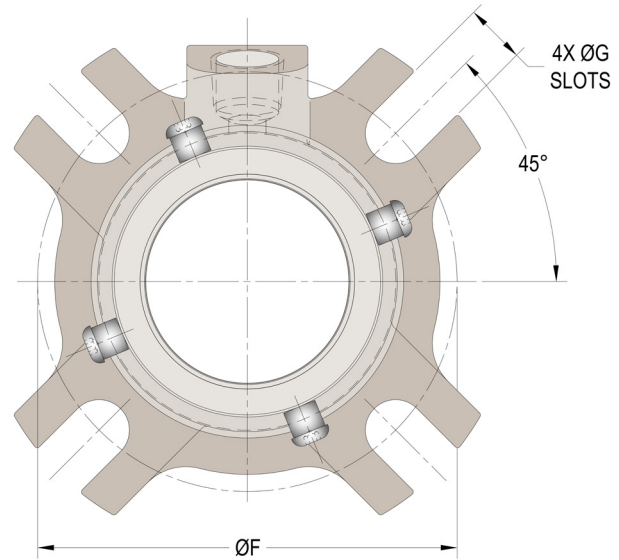
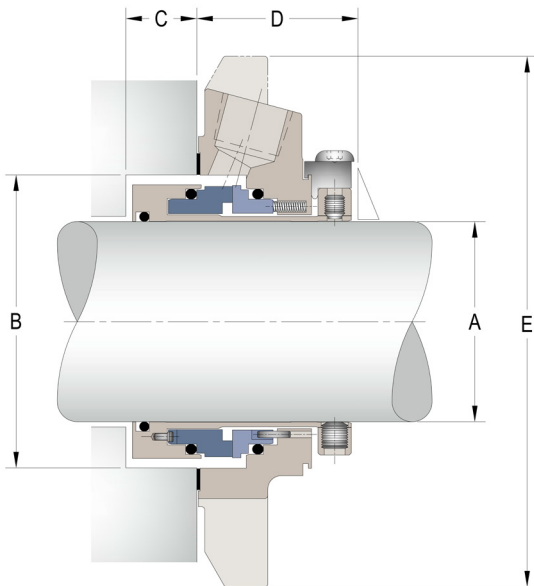
**Standard bore seal chamber**
*mm dimensions*

Seal Size, A (Shaft)	B Min	B Max	C Min	D Min	E Max	F Min	G Max
33	50.8	60.3	16.8	38.4	111	82.6	11.2
35	50.8	60.3	16.8	38.4	111	82.6	11.2
38	57.2	64.2	16.8	38.4	121	95.3	14.2
40	60.3	70.6	16.8	38.4	121	95.3	14.2
43	63.5	73.1	16.8	38.4	127	98.4	14.2
45	65.0	74.0	16.8	38.4	127	98.4	14.2
50	70.0	70.0	16.8	38.4	124	98.4	13.5
53	73.0	85.0	16.8	38.4	152	112.8	19.1
55	75.0	85.0	17.3	38.4	152	112.8	19.1
65	89.9	97.9	22.1	43.2	190	127.0	19.1
70	95.3	107.4	26.9	43.2	203	138.9	19.3

**Standard bore seal chamber**
*in. dimensions*

Seal Size, A (Shaft)	B Min	B Max	C Min	D Min	E Max	F Min	G Max
1.125	1.750	2.000	0.66	1.51	3.75	2.875	0.44
1.250	1.890	2.246	0.66	1.51	4.25	3.125	0.56
1.375	2.000	2.374	0.66	1.51	4.38	3.250	0.56
1.625	2.375	2.781	0.66	1.51	4.78	3.750	0.56
1.750	2.500	2.876	0.66	1.51	5.00	3.875	0.56
1.875	2.625	2.875	0.66	1.51	5.00	3.875	0.56
2.125	2.875	3.125	0.68	1.51	6.00	4.440	0.75
2.500	3.375	3.687	0.73	1.51	6.38	4.875	0.75
2.625	3.625	4.313	1.07	1.70	7.25	5.625	0.88
2.750	3.750	4.312	1.06	1.70	7.25	5.625	0.88

**Large bore seal chamber**
*mm dimensions*

Seal Size, A (Shaft)	B Min	B Max	C Min	D Min	E Max	F Min	G Max
35	73.0	78.0	16.8	38.4	118	98.0	11.9
45	88.0	104.8	16.8	38.4	165	128.6	14.2
55	88.0	100.0	17.3	38.4	154	124.5	14.2
65	100.0	116.0	22.1	43.2	190	140.0	13.5

**Large bore seal chamber**
*in. dimensions*

Seal Size, A (Shaft)	B Min	B Max	C Min	D Min	E Max	F Min	G Max
1.125	2.625	2.907	0.66	1.51	4.50	3.750	0.44
1.375	2.875	3.163	0.66	1.51	5.25	4.000	0.44
1.750	3.500	4.152	0.66	1.51	6.50	5.062	0.56
1.875	3.625	3.907	0.66	1.51	5.88	5.000	0.56
2.125	3.870	4.608	0.68	1.51	7.00	5.625	0.75
2.500	4.547	4.859	0.73	1.51	7.13	6.000	0.56
2.625	4.625	4.913	1.06	1.70	7.00	6.000	0.56
2.750	4.750	5.242	1.06	1.70	8.00	6.750	0.75

**Durco ISO FM Seal Chamber**
*mm dimensions*

Seal Size, A (Shaft)	B Min	B Max	C Min	D Min	E Max	F Min	G Max
35	57.0	57.2	16.8	38.4	111	86.0	11.9
45	69.9	70.1	16.8	38.4	127	100.0	14.2
55	84.9	85.1	17.3	38.4	152	116.0	14.2
65	94.9	95.1	22.1	43.2	190	130.0	14.2

**Durco ISO CB Seal Chamber**
*mm dimensions*

Seal Size, A (Shaft)	B Min	B Max	C Min	D Min	E Max	F Min	G Max
35	73.0	73.1	16.8	38.4	118	98.0	11.9
45	89.0	89.1	16.8	38.4	150	117.0	14.2
55	100.0	100.1	17.3	38.4	154	130.0	14.2
65	116.0	116.1	22.1	43.2	190	144.0	14.2