

BINKS "TROPHY" SERIES TOUCH-UP SPRAY GUNS GRAVITY FEED HVLP & LVMP (1466-XXXX-XXX)

Binks Trophy Series Touch-up Gravity Spray Gun is the premier spray gun for use in gravity feed touch-up and light production spray applications and sets a new standard in durability, ergonomics, and atomization. The lightweight ergonomic design offers unsurpassed comfort and control. The latest advanced atomization technology has been incorporated for achieving consistent, fine finishes when spraying a wide range of industrial coating applications.

Binks Trophy Series Touch-up Gravity Spray Guns are offered in two different atomization technologies: HVLP and LVMP.



SPECIFICATIONS

Maximum Air Pressure	100 psi / 6.9 bar (P-1)
Gun Body	Anodized Aluminum
Fluid Path	Stainless Steel
Fluid Inlet Size	7/16 – 14(f)
Air Inlet Size	1/4" NPS / BSP(m)
Gun Weight (less cup)	12 oz. / 348 grams
Wetted Parts (gun)	Stainless Steel & PTFE
Wetted Parts (cup)	Aluminum and Plated Brass

The Trophy HVLP Series of Spray Guns can be used to operate at high transfer efficiencies in compliance with "California South Coast Air Quality Management District" regulations as a High Volume, Low Pressure spray gun.

IMPORTANT! DO NOT DESTROY

It is the customer's responsibility to have all operators and service personnel read and understand this manual. Contact your local Binks representative for additional copies of this manual.

READ ALL INSTRUCTIONS BEFORE OPERATING THIS BINKS PRODUCT.

Product Description/Object of Declaration: Trophy

This Product is designed for use with: Solvent and Water based Materials

Suitable for use in hazardous area: Zone 1 / Zone 2

Protection Level: II 2 G X

Notified body details and role: TRAC Global Ltd (0891)
Lodging of Technical file

This Declaration of Conformity /incorporation is issued under the sole responsibility of the manufacturer: Carlisle Fluid Technologies,
320 Phillips Ave.,
Toledo, OH 43612

EU Declaration of Conformity



The object of the declaration described above is in conformity with the relevant Union harmonisation legislation:

Machinery Directive 2006/42/EC
ATEX Directive 2014/34/EU
by complying with the following statutory documents and harmonized standards:
EN ISO 12100:2010 Safety of Machinery - General Principles for Design
BS EN 1953:2013 Atomising and spraying equipment for coating materials - Safety requirements
EN 1127-1:2011 Explosive atmospheres - Explosion prevention - Basic concepts
EN 13463-1:2009 Non electrical equipment for use in potentially explosive atmospheres - Basic methods and requirements

Providing all conditions of safe use / installation stated within the product manuals have been complied with and also installed in accordance with any applicable local codes of practice.

Signed for and on behalf of
Carlisle Fluid Technologies:

DJ Hasselschwert
11-Jul-16

(Vice President: Global
Product Development)
Toledo, OH 43612

In this part sheet, the words **WARNING**, **CAUTION** and **NOTE** are used to emphasize important safety information as follows:

! WARNING
Hazards or unsafe practices which could result in severe personal injury, death or substantial property damage.

! CAUTION
Hazards or unsafe practices which could result in minor personal injury, product or property damage.

NOTE
Important installation, operation or maintenance information.

! WARNING

Read the following warnings before using this equipment.



READ THE MANUAL

Before operating finishing equipment, read and understand all safety, operation and maintenance information provided in the operation manual.



WEAR SAFETY GLASSES

Failure to wear safety glasses with side shields could result in serious eye injury or blindness.



DE-ENERGIZE, DEPRESSURIZE, DISCONNECT AND LOCK OUT ALL POWER SOURCES DURING MAINTENANCE

Failure to De-energize, disconnect and lock out all power supplies before performing equipment maintenance could cause serious injury or death.



OPERATOR TRAINING

All personnel must be trained before operating finishing equipment.



EQUIPMENT MISUSE HAZARD

Equipment misuse can cause the equipment to rupture, malfunction, or start unexpectedly and result in serious injury.



KEEP EQUIPMENT GUARDS IN PLACE

Do not operate the equipment if the safety devices have been removed.

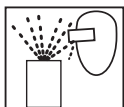

PROJECTILE HAZARD

You may be injured by venting liquids or gases that are released under pressure, or flying debris.

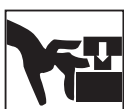

PINCH POINT HAZARD

Moving parts can crush and cut. Pinch points are basically any areas where there are moving parts.



INSPECT THE EQUIPMENT DAILY

Inspect the equipment for worn or broken parts on a daily basis. Do not operate the equipment if you are uncertain about its condition.



NEVER MODIFY THE EQUIPMENT

Do not modify the equipment unless the manufacturer provides written approval.



KNOW WHERE AND HOW TO SHUT OFF THE EQUIPMENT IN CASE OF AN EMERGENCY



PRESSURE RELIEF PROCEDURE

Always follow the pressure relief procedure in the equipment instruction manual.



NOISE HAZARD

You may be injured by loud noise. Hearing protection may be required when using this equipment.



STATIC CHARGE

Fluid may develop a static charge that must be dissipated through proper grounding of the equipment, objects to be sprayed and all other electrically conductive objects in the dispensing area. Improper grounding or sparks can cause a hazardous condition and result in fire, explosion or electric shock and other serious injury.



FIRE AND EXPLOSION HAZARD

Never use 1,1,1-trichloroethane, methylene chloride, other halogenated hydrocarbon solvents or fluids containing such solvents in equipment with aluminum wetted parts. Such use could result in a serious chemical reaction, with the possibility of explosion. Consult your fluid suppliers to ensure that the fluids being used are compatible with aluminum parts.

IT IS THE RESPONSIBILITY OF THE EMPLOYER TO PROVIDE THIS INFORMATION TO THE OPERATOR OF THE EQUIPMENT.

**FOR FURTHER SAFETY INFORMATION REGARDING BINKS AND DEVILBISS EQUIPMENT,
SEE THE GENERAL EQUIPMENT SAFETY BOOKLET (77-5300).**

BINKS "TROPHY" SERIES GRAVITY SPRAY GUN

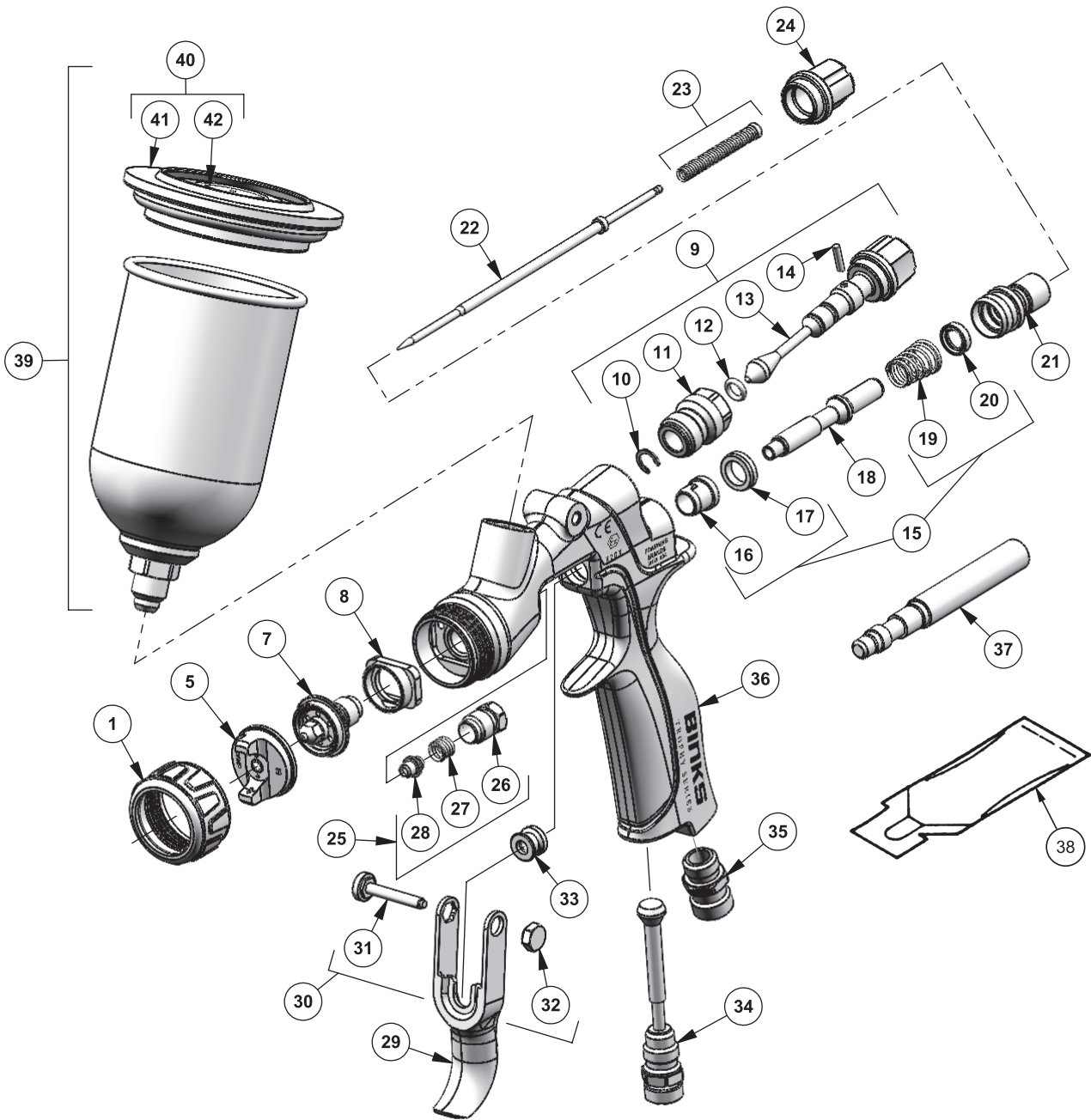

SELECTION GUIDE FOR BINKS "TROPHY" SERIES TOUCH-UP GRAVITY SPRAY GUNS

TYPE OF FLUID TO BE SPRAYED	COMPLETE GUN ASSEMBLY PART NUMBER	FLUID NOZZLE AND AIR CAP	SPRAY TECHNOLOGY
LIGHT/MEDIUM 15 - 20 seconds, Zahn 2 Stains, varnishes, thin lacquers, automotive refinishing materials	1466-10LV-A1S	1.0 mm X A1	ROUND
	1466-10LV-B1S	1.0 mm X B1	LVMP
	1466-10HV-C1S	1.0 mm X C1	HVLP
MEDIUM 20 - 30 seconds, Zahn 2 General industrial coatings, enamels, epoxies, fine grit ceramics	1466-12LV-B1S	1.2 mm X B1	LVMP
	1466-12HV-C1S	1.2 mm X C1	HVLP

CHART 1: BINKS "TROPHY" SERIES TOUCH-UP GRAVITY SPRAY GUN PARTS LIST

ITEM NO.	PART NUMBER	DESCRIPTION	QTY.	ITEM NO.	PART NUMBER	DESCRIPTION	QTY.
1	54-6211	AIR CAP RETAINING RING ASSEMBLY	1	23	54-6223-K	☐ SPRING/PAD ASSEMBLY	1
5	SEE CHARTS BELOW	AIR CAP	1	24	54-6111	KNOB – NEEDLE ADJUSTING	1
7	SEE CHARTS BELOW	FLUID NOZZLE	1	25	54-6130-K	☐ NEEDLE PACKING KIT	1
8	54-6215-K5	BAFFLE/SEPARATOR (KIT OF 5)	1	26	-----	■ NUT – PACKING	1
9	54-6216	SIDE PORT VALVE ASSEMBLY	1	27	-----	■ SPRING FOR PACKING	1
10	-----	+ Δ RETAINING CLIP	1	28	-----	■ ▼ NEEDLE PACKING	1
11	-----	+ BODY BUSHING	1	29	54-6218	TRIGGER	1
12	-----	+ Δ O-RING	1	30	54-6228-K	TRIGGER SCREW NUT KIT	1
13	-----	+ SIDE PORT STEM	1	31	-----	○ TRIGGER SCREW	1
14	-----	+ Δ PIN	1	32	-----	○ TRIGGER NUT	1
15	54-6131-K	☐ AIR VALVE SERVICE KIT	1	33	54-3513	SPINDLE CAP	1
16	-----	• FRONT SEAL – AIR VALVE	1	34	JJ-42	AIR ADJUSTING VALVE ASSEMBLY	1
17	-----	• FRONT AIR VALVE SEAL	1	35	JJ-30	FITTING – AIR INLET	1
18	54-6220	☐ AIR VALVE SPINDLE	1	36	-----	GUN BODY	1
19	-----	• AIR VALVE SPRING	1	37	SPN-7	TOOL – SEAL INSERTION	1
20	-----	• REAR SEAL – AIR VALVE	1	38	-----	GUNNER'S MATE (3 CC TUBE)	1
21	SN-66	HOUSING		39	54-4458	4 OZ. GRAVITY CUP ASSEMBLY	1
22	47-6851	NEEDLE – STAINLESS STEEL (STD.)	1	40	54-4459	* LID ASSEMBLY	1
	47-6852	NEEDLE – PLASTIC TIP	1	41	-----	CUP LID	1
				42	-----	CUP LID	1

+ PARTS INCLUDED IN 54-6216 • PARTS INCLUDED IN 54-6131-K Δ GTI-428-K5 SIDE PORT REPAIR KIT * AVAILABLE IN KIT 54-4539 (SET OF 3)
 ■ PARTS INCLUDED IN 54-6130-K ○ PARTS INCLUDED IN 54-6228-K ▼ ALSO AVAILABLE IN KIT OF 3: SN-2-K3 ☐ PARTS INCLUDED IN 54-6136

CHART 2: AIR CAP OPTIONS

DESIGNATION	ATOMIZATION TECHNOLOGY	PART NUMBER
A1	Round Spray	46-10020
B1	LVMP	46-10010
C1	HVLP	46-10000

CHART 4: LVMP AIR PRESSURES AND FLOWS

GUN INLET PRESSURE (PSI)	AIR CAP AIR FLOW (SCFM)
15	4.7
20	5.8
25	6.9
30	7.8

HVLP TEST KIT FOR C1 AIR CAP: 54-6226

ITEM NO.	PART NO.	DESCRIPTION	QTY.
1	54-6227	HVLP TEST AIR CAP	1
2	---	MINI VINYL HOSE	1
3	---	BARBED CLIP	1
4	GA-313	GAUGE 15 PSI, 1-1/2" DIA.	1

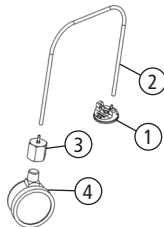

CHART 3: HVLP AIR PRESSURES AND FLOWS

GUN INLET PRESSURE (PSI)	AIR CAP AIR FLOW (SCFM)	AIR CAP ATOMIZING PRESSURE (PSI)
5	2.5	2
10	4.0	4
15	5.1	7
21	6.4	10

GUN INLET PRESSURE IS MEASURED AT THE GUN INLET FITTING WITH THE GUN TRIGGERED.

CHART 5: HARDENED STAINLESS STEEL FLUID NOZZLE OPTIONS

MATERIAL	PART NO. / ORIFICE
VERY LIGHT / REDUCED FLOW	45-12080 0.8mm (.030")
LIGHT/MEDIUM 15 - 20 seconds, Zahn 2 Stains, varnishes, thin lacquers, automotive refinishing materials	45-12100 1.0mm (.040")
MEDIUM 20 - 30 seconds, Zahn 2 General industrial coatings, enamels, epoxies, fine grit ceramics	45-12120 1.2mm (.047")
HEAVY Greater than 30 seconds, Zahn 2 Low VOC coatings, adhesives, fine grit ceramics	45-12140 1.4mm (.055")

TYPES OF INSTALLATION

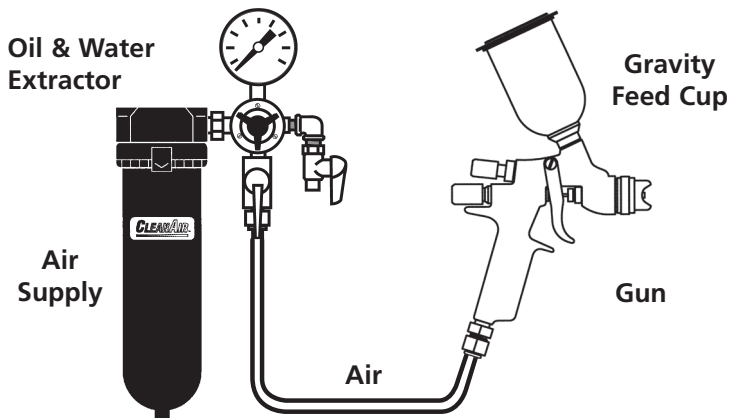

Air pressure for atomization is regulated at the extractor. The flow of the fluid is adjusted by the fluid valve control knob on gun, viscosity of paint and air pressure.

GRAVITY FEED HOOKUP

On gravity-feed spray guns the cup is located above the gun. The force of gravity pushes the fluid into the gun.

Advantages: this method offers quick color changes and convenience on small jobs or touch-up applications. Gravity spray guns are able to use all of the coating—reducing waste.

AIR PRESSURE

Atomizing pressure must be set properly to allow for the drop in air pressure between the regulator and the spray gun.

WITH 60 PSI APPLIED AT AIR SUPPLY

Cross section view showing comparison of inside hose diameters (actual size). 60 lbs. regulated pressure



5/16"

RECOMMENDED
48 PSI at gun inlet

25 feet of 5/16" I.D. hose causes a drop of 12 PSI between the air supply and the gun. For this reason Binks recommends the use of 5/16" hose.



1/4"

NOT RECOMMENDED
Only 34 PSI at gun inlet

25 feet of 1/4" I.D. hose causes a drop of 26 PSI between the air supply and the gun.



An oil and water extractor is important.

Achieving a fine spray finish without the use of a good oil and water extractor is virtually impossible.

A regulator/extractor serves a double purpose. It eliminates blistering and spotting by keeping air free of oil and water, and it gives precise air pressure control at the gun.

Use DeVilbiss oil and water extractors and regulators. See your local distributor for models.

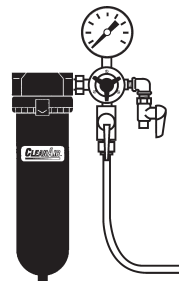

INSTALLATION INSTRUCTIONS

For maximum transfer efficiency, do not use more pressure than is necessary to atomize the material being applied.

NOTE

When using HVLP do not exceed inlet pressures listed on page 5.

1. Connect the gun to a clean, moisture and oil free air supply using a conductive hose of at least 5/16 in I.D.

NOTE

Depending on hose length, larger I.D. hose may be required. Install an air gauge at the gun handle. See page 5 for operating pressures. Do not use more pressure than is necessary to atomize the material being applied. Excess pressure will create additional overspray and reduce transfer efficiency.

NOTE

If quick connect couplings are required, use only high flow quick connects approved for HVLP use. Other types will not flow enough air for correct gun operation.

NOTE

If an air adjusting valve is used at the gun inlet, use HAV-501 adjusting valve.

NOTE

Before using the spray gun, flush it with solvent to ensure that the fluid passages are clean.

OPERATION

GRAVITY MODELS

1. Mix coating material to manufacturer's instructions and strain material.
2. Fill the cup to no more than 3/4 inch from the top of the cup. DO NOT OVERFILL.
3. Attach to cup lid.
4. Turn fluid adjusting knob (24) clockwise to prevent fluid needle movement.
5. Turn sideport control (9) counter clockwise to fully open.
6. Adjust inlet air pressure if required.
7. Turn fluid adjusting knob counter clockwise until first thread shows.
8. Test spray. If the finish is too dry, reduce airflow by reducing air inlet pressure.

9. If finish is too wet, reduce fluid flow by turning fluid adjusting knob (24) clockwise. If atomization is too coarse, increase inlet air pressure. If too fine, reduce inlet pressure.
10. The pattern size can be reduced by turning sideport control (9) clockwise.
11. Hold gun perpendicular to surface being sprayed. Arcing or tilting may result in uneven coating.
12. The recommended spray distance is 8 inches.
13. Spray edges first. Overlap each stroke a minimum of 75%. Move gun at a constant speed.
14. Always turn off air supply and relieve pressure when gun is not in use.

PREVENTIVE MAINTENANCE AND CLEANING

To clean air cap and fluid nozzle, brush exterior with a stiff bristle brush. If necessary to clean cap holes, use a broom straw or toothpick if possible. If a wire or hard instrument is used, extreme care must be used to prevent scratching or burring of the holes which will cause a distorted spray pattern.

To clean fluid passages, remove excess material from gun, then flush with gun wash solution. Wipe the gun exterior with a dampened cloth. Never completely immerse in any solvent or cleaning solutions as this is detrimental to the lubricants and life of the spray gun.

NOTE

When replacing the fluid nozzle (7) or fluid needle (22), replace both at the same time. Using worn parts can cause fluid leakage. See page 4. Also, replace the needle packing at this time. Torque the fluid nozzle to 170–180 inch-lbs. Do not over tighten.

CAUTION

To prevent damage to fluid nozzle (7) or fluid needle (22), be sure to either 1) pull the trigger and hold while tightening or loosening the fluid nozzle, or 2) remove fluid adjusting knob (24) to relieve spring pressure against needle collar.

GRAVITY CUP. Empty excess material and clean the cup. Make sure the vent hole in the lid is clear.

REMOVAL AND INSTALLATION PROCEDURES

NEEDLE AND VALVE DISASSEMBLY AND ASSEMBLY

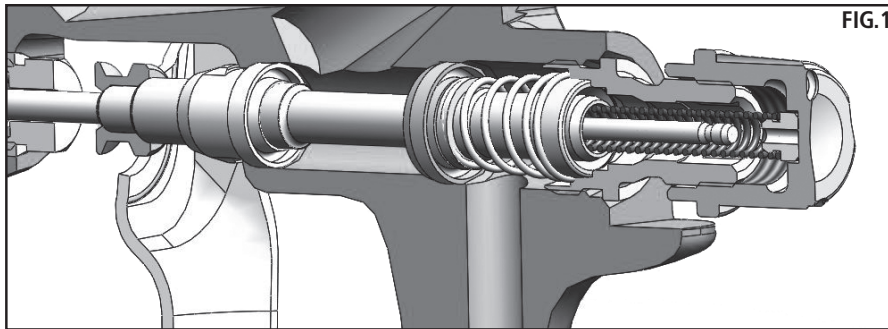

DISASSEMBLY

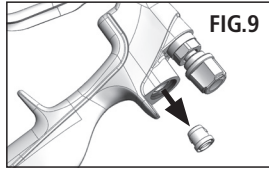
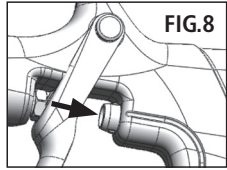
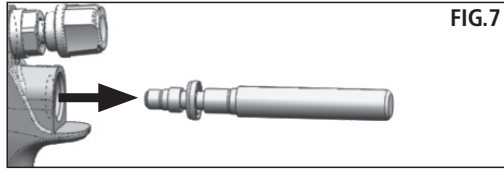
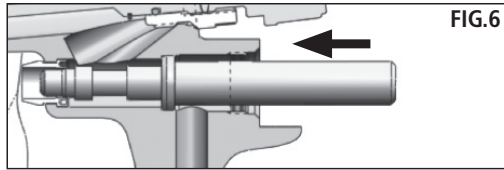
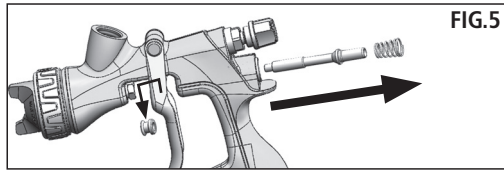
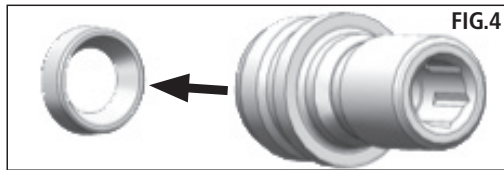
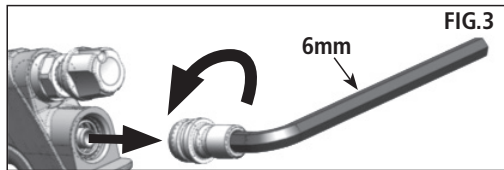
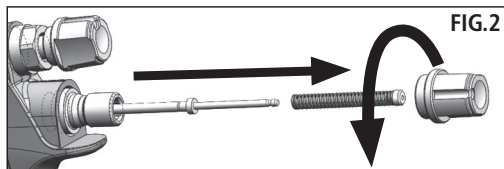

ASSEMBLY

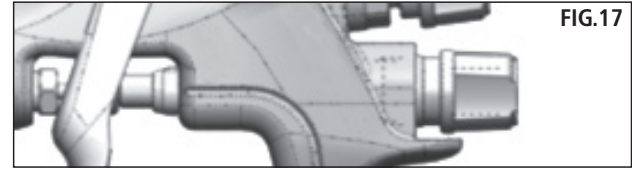
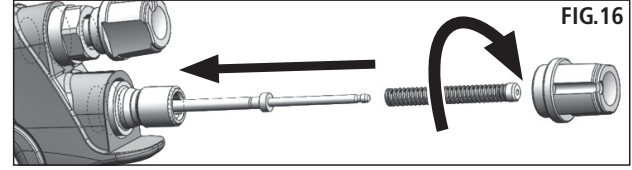
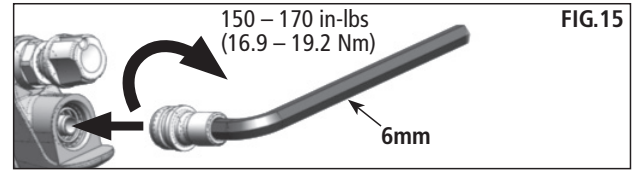
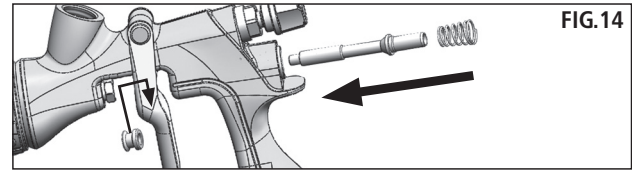
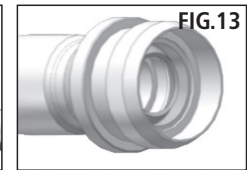
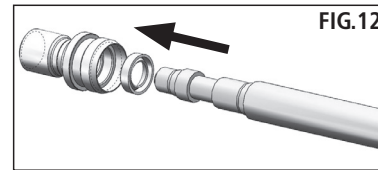
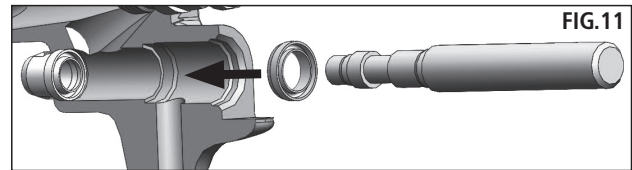
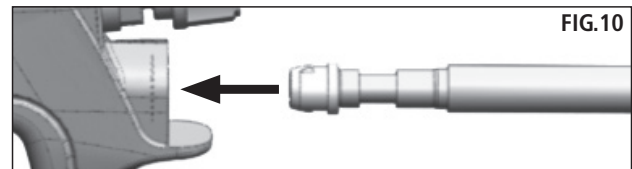

MAINTENANCE – FLUID NOZZLE AND BAFFLE REMOVAL AND INSTALLATION

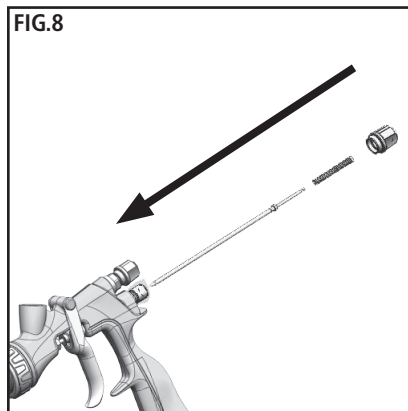
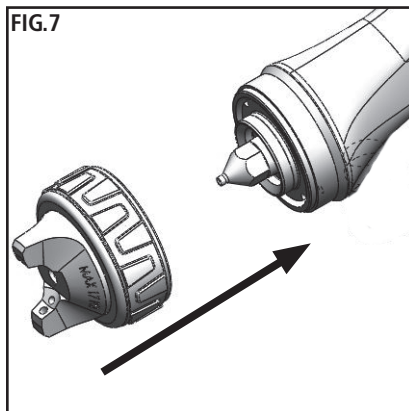
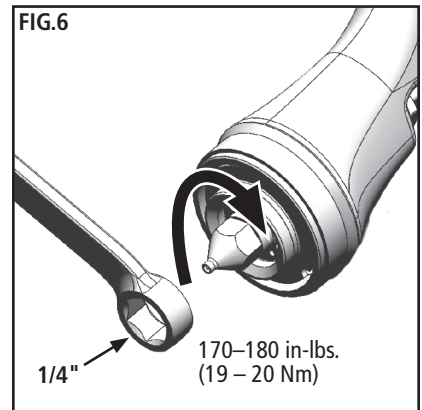
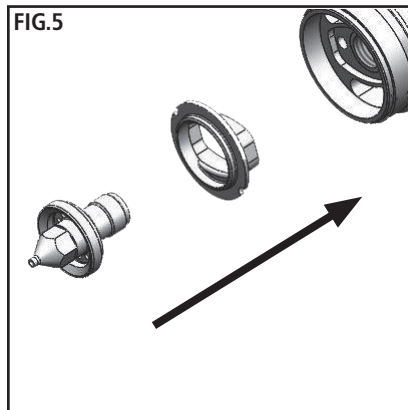
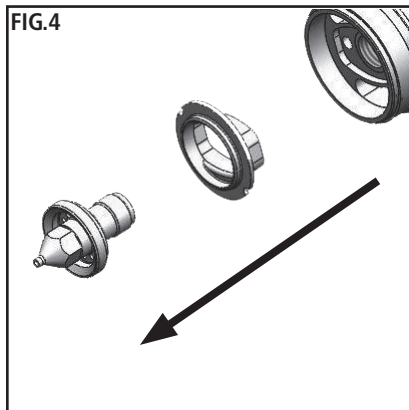
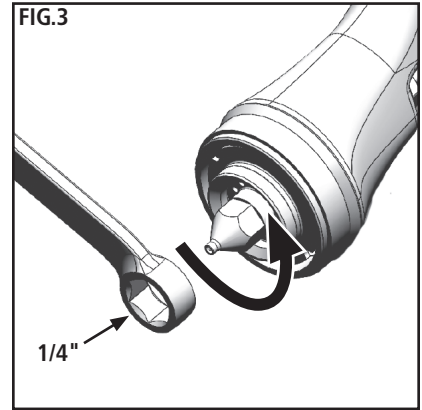
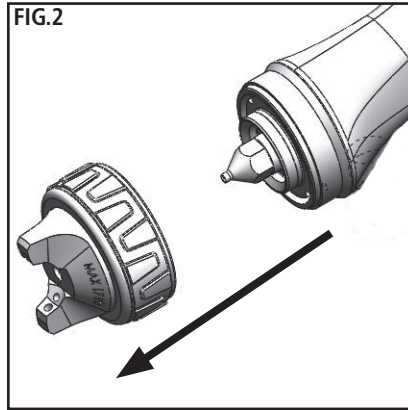
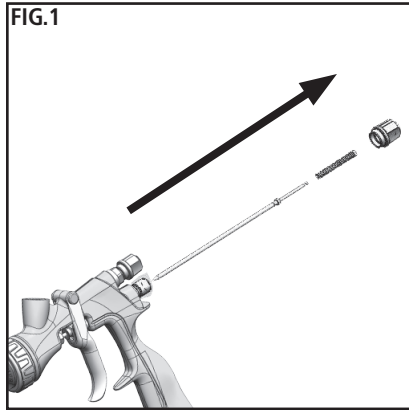



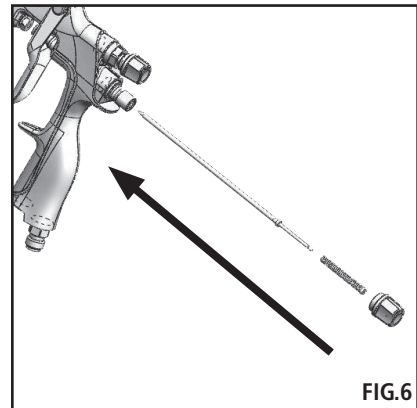
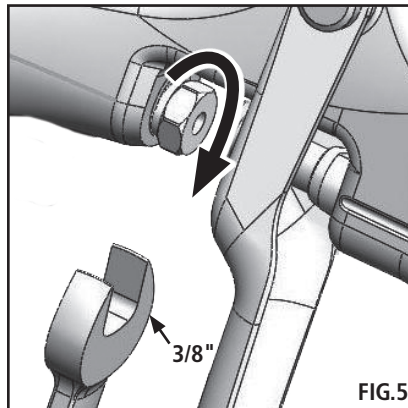
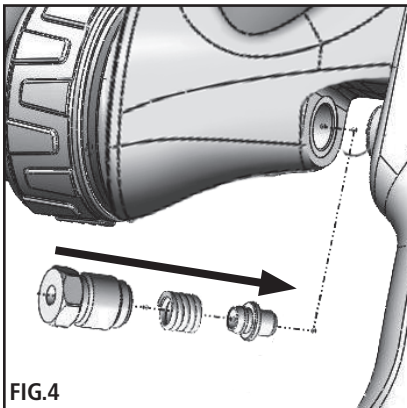
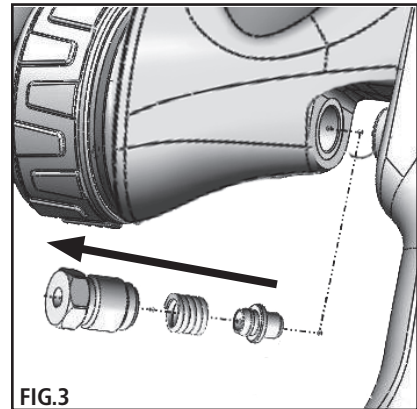
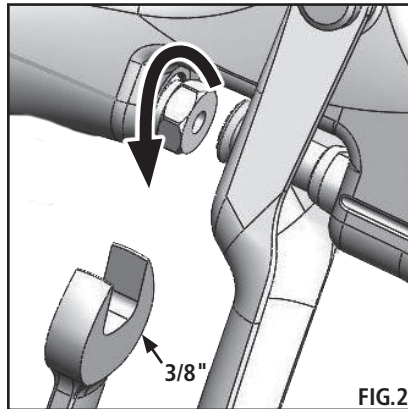
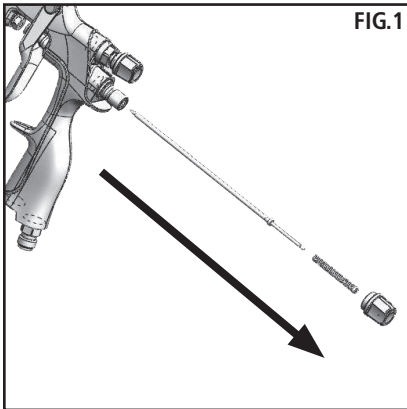

MAINTENANCE – NEEDLE PACKING REMOVAL AND INSTALLATION

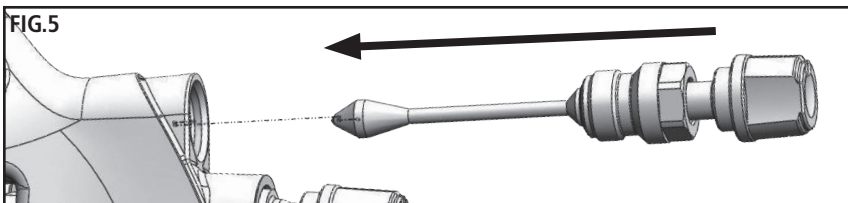
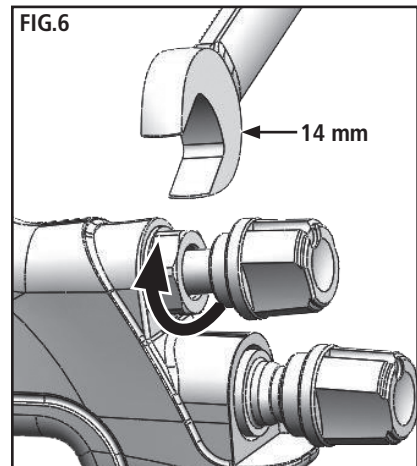
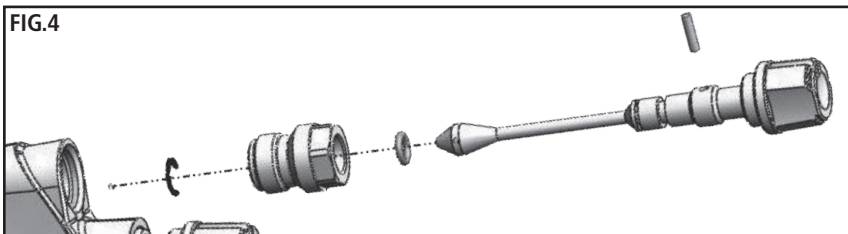
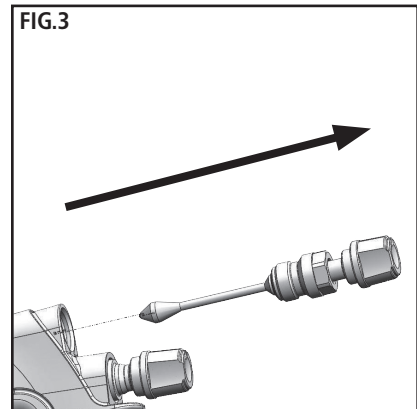
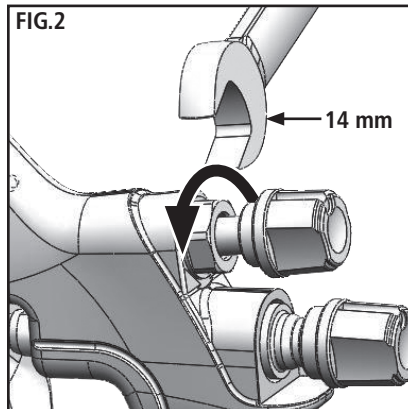
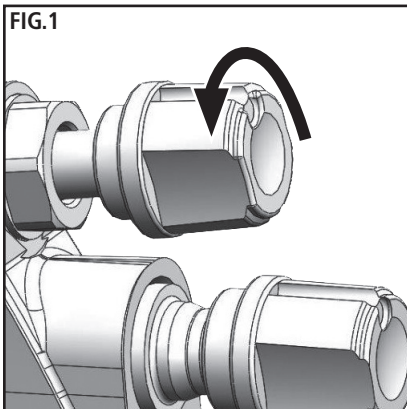

MAINTENANCE – SIDEPORT REMOVAL AND INSTALLATION



TROUBLESHOOTING

CONDITION	CAUSE	CORRECTION
Heavy top or bottom pattern 	Horn holes plugged. Obstruction on top or bottom of fluid tip. Cap and/or tip seat dirty.	Clean. Ream with non-metallic point. Clean. Clean.
Heavy right or left side pattern 	Left or right side horn holes plugged. Dirt on left or right side of fluid tip.	Clean. Ream with non-metallic point. Clean.
	Remedies for the top-heavy, bottom-heavy, right-heavy, and left-heavy patterns: 1. Determine if the obstruction is on the air cap or the fluid tip. Do this by making a test spray pattern. Then, rotate the cap one-half turn and spray another pattern. If the defect is inverted, obstruction is on the air cap. Clean the air cap as previously instructed. 2. If the defect is not inverted, it is on the fluid tip. Check for a fine burr on the edge of the fluid tip. Remove with #600 wet or dry sand paper. 3. Check for dried paint just inside the opening; remove by washing with solvent.	
Heavy center pattern 	Fluid flow too high for atomization air. Material flow exceeds air cap's capacity. Spreader adjustment valve set too low. Atomizing pressure too low. Material too thick.	Balance air pressure and fluid flow. Increase spray pattern width with spreader adjustment valve. Thin or lower fluid flow. Adjust. Increase pressure. Thin to proper consistency.
Split spray pattern 	Atomization air pressure too high. Fluid flow too low. Spreader adjusting valve set too high.	Reduce at transformer or gun. Increase fluid flow (increases gun handling speed). Adjust.
Jerky or fluttering spray 	*Loose or damaged fluid tip/seat. Material level too low. Container tipped too far. Obstruction in fluid passage. Dry or loose fluid needle packing nut.	Tighten or replace. Refill. Hold more upright. Backflush with solvent. Lubricate or tighten.
Unable to get round spray	Spreader adjustment screw not seating properly. Air cap retaining ring loose.	Clean or replace. Tighten.
Will not spray	No air pressure at gun. Fluid needle adjusting screw not open enough. Fluid too heavy for gravity feed.	Check air supply and air lines, blow out gun air passages. Open fluid needle adjusting screw. Thin material and/or change to larger tip size.
Paint bubbles in cup	Fluid tip not tight.	Tighten tip.
Fluid leaking or dripping from cup lid	Cup lid loose. Dirty threads on cup or lid. Cracked cup or lid.	Tighten lid. Clean. Replace cup and lid.

*Most common problem.

TROUBLESHOOTING

CONDITION	CAUSE	CORRECTION
Starved spray pattern	Inadequate material flow. Low atomization air pressure.	Back fluid adjusting screw out to first thread, or change to larger tip size. Increase air pressure and rebalance gun.
Excessive overspray	Too much atomization air pressure. Gun too far from work surface. Improper stroking (arcing, gun motion too fast).	Reduce pressure. Adjust to proper distance. Move at moderate pace, parallel to work surface.
Excessive fog	Too much or too fast-drying thinner. Too much atomization (air pressure.)	Remix properly. Reduce air pressure.
Dry spray	Air pressure too high. Gun tip too far from work surface. Gun motion too fast. Gun out of adjustment.	Reduce air pressure. Adjust to proper distance. Slow down. Adjust.
Fluid leaking from packing nut	Packing nut loose. Packing worn or dry.	Tighten, do not bind needle. Replace or lubricate.
Fluid leaking or dripping from front of gun	Packing nut too tight. Dry packing. Fluid tip or needle worn or damaged. Foreign matter in tip. Fluid needle spring broken. Wrong size needle or tip.	Adjust. Lubricate. Replace tip and needle. Clean. Replace. Replace.
Fluid dripping or leaking from bottom of cup	Cup loose on gun. Cup gasket worn or missing below cup. Cup threads dirty.	Tighten. Replace cup gasket. Clean.
Runs and sags	Too much material flow. Material too thin. Gun tilted on an angle, or gun motion too slow.	Adjust gun or reduce fluid flow. Mix properly or apply light coats. Hold gun at right angle to work and adapt to proper gun technique.
Thin, sandy coarse finish drying before it flows out	Gun too far from surface. Too much air pressure. Improper thinner being used.	Check distance. Normally approximately 8". Reduce air pressure and check spray pattern. Follow paint manufacturer's mixing instructions.
Thick, dimpled finish "orange peel"	Gun too close to surface. Too much material coarsely atomized. Air pressure too low. Improper thinner being used. Material not properly mixed. Surface rough, oily, dirty.	Check distance. Normally approximately 8". Follow paint manufacturer's mixing instructions. Increase air pressure or reduce fluid flow. Follow paint manufacturer's mixing instructions. Follow paint manufacturer's mixing instructions. Follow paint manufacturer's mixing instructions. Properly clean and prepare.

WARRANTY POLICY

This product is covered by Carlisle Fluid Technologies’ materials and workmanship limited warranty. The use of any parts or accessories, from a source other than Carlisle Fluid Technologies, will void all warranties. Failure to reasonably follow any maintenance guidance provided may invalidate any warranty.

For specific warranty information please contact Carlisle Fluid Technologies.

Carlisle Fluid Technologies is a global leader in innovative finishing technologies. Carlisle Fluid Technologies reserves the right to modify equipment specifications without prior notice.

DeVilbiss®, Ransburg®, ms®, BGK®, and Binks® are registered trademarks of Carlisle Fluid Technologies, Inc.

©2020 Carlisle Fluid Technologies, Inc.
All rights reserved.

For technical assistance or to locate an authorized distributor, contact one of our international sales and customer support locations.

Region	Industrial / Automotive	Automotive Refinishing
Americas	Tel: 1-800-992-4657 Fax: 1-888-246-5732	Tel: 1-800-445-3988 Fax: 1-800-445-6643
Europe, Africa, Middle East, India	Tel: +44 (0)1202 571 111 Fax: +44 (0)1202 573 488	
China	Tel: +8621-3373 0108 Fax: +8621-3373 0308	
Japan	Tel: +81 45 785 6421 Fax: +81 45 785 6517	
Australia	Tel: +61 (0) 2 8525 7555 Fax: +61 (0) 2 8525 7575	

For the latest information about our products, visit www.carlisleleft.com