



**“TROPHY” SERIES TOUCH-UP SPRAY GUNS  
PRESSURE AND SIPHON FEED HVLP & LVMP  
(1465-XXXX-XXXX)**



Binks Trophy Series Touch-up Spray Gun is the premier spray gun for use in pressure feed touch-up and light production spray applications and sets a new standard in durability, ergonomics, and atomization. The lightweight ergonomic design offers unsurpassed comfort and control. The latest advanced atomization technology has been incorporated for achieving consistent, fine finishes when spraying a wide range of industrial coating applications.

Binks Trophy Series Touch-up Spray Guns can be used with pumps, pressure pots, pressure cups, or siphon cups.

Binks Trophy Series Touch-up Spray Guns are offered in two different atomization technologies: HVLP and LVMP.



**SPECIFICATIONS**

Maximum Air Pressure	100 psi / 6.9 bar (P-1)
Maximum Fluid Pressure	100 psi / 6.9 bar (P-2)
Gun Body	Anodized Aluminum
Fluid Path	Stainless Steel
Fluid Inlet Size	3/8" NPS / BSP(m)
Air Inlet Size	1/4" NPS / BSP(m)
Gun Weight	13 oz. / 374 grams
Wetted Parts	Stainless Steel & PTFE

**The Trophy HVLP Series of Spray Guns can be used to operate at high transfer efficiencies in compliance with “California South Coast Air Quality Management District” regulations as a High Volume, Low Pressure spray gun.**

**IMPORTANT! DO NOT DESTROY**

It is the customer's responsibility to have all operators and service personnel read and understand this manual. Contact your local Binks representative for additional copies of this manual.

**READ ALL INSTRUCTIONS BEFORE OPERATING THIS BINKS PRODUCT.**

**Product Description/Object of Declaration:** Trophy

**This Product is designed for use with:** Solvent and Water based Materials

**Suitable for use in hazardous area:** Zone 1 / Zone 2

**Protection Level:** II 2 G X

**Notified body details and role:** TRAC Global Ltd (0891)  
Lodging of Technical file

**This Declaration of Conformity /incorporation is issued under the sole responsibility of the manufacturer:** Carlisle Fluid Technologies,  
320 Phillips Ave.,  
Toledo, OH 43612

### EU Declaration of Conformity



**The object of the declaration described above is in conformity with the relevant Union harmonisation legislation:**

Machinery Directive 2006/42/EC  
ATEX Directive 2014/34/EU  
by complying with the following statutory documents and harmonized standards:  
EN ISO 12100:2010 Safety of Machinery - General Principles for Design  
BS EN 1953:2013 Atomising and spraying equipment for coating materials - Safety requirements  
EN 1127-1:2011 Explosive atmospheres - Explosion prevention - Basic concepts  
EN 13463-1:2009 Non electrical equipment for use in potentially explosive atmospheres - Basic methods and requirements

Providing all conditions of safe use / installation stated within the product manuals have been complied with and also installed in accordance with any applicable local codes of practice.

Signed for and on behalf of  
Carlisle Fluid Technologies:

DJ Hasselschwert  
11-Jul-16

(Vice President: Global  
Product Development)  
Toledo, OH 43612

In this part sheet, the words **WARNING**, **CAUTION** and **NOTE** are used to emphasize important safety information as follows:

**⚠ WARNING**  
Hazards or unsafe practices which could result in severe personal injury, death or substantial property damage.

**⚠ CAUTION**  
Hazards or unsafe practices which could result in minor personal injury, product or property damage.

**NOTE**  
Important installation, operation or maintenance information.

## ⚠ WARNING

Read the following warnings before using this equipment.



### READ THE MANUAL

Before operating finishing equipment, read and understand all safety, operation and maintenance information provided in the operation manual.



### WEAR SAFETY GLASSES

Failure to wear safety glasses with side shields could result in serious eye injury or blindness.



### DE-ENERGIZE, DEPRESSURIZE, DISCONNECT AND LOCK OUT ALL POWER SOURCES DURING MAINTENANCE

Failure to De-energize, disconnect and lock out all power supplies before performing equipment maintenance could cause serious injury or death.



### OPERATOR TRAINING

All personnel must be trained before operating finishing equipment.



### EQUIPMENT MISUSE HAZARD

Equipment misuse can cause the equipment to rupture, malfunction, or start unexpectedly and result in serious injury.



### KEEP EQUIPMENT GUARDS IN PLACE

Do not operate the equipment if the safety devices have been removed.

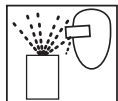

### PROJECTILE HAZARD

You may be injured by venting liquids or gases that are released under pressure, or flying debris.



### PINCH POINT HAZARD

Moving parts can crush and cut. Pinch points are basically any areas where there are moving parts.



### INSPECT THE EQUIPMENT DAILY

Inspect the equipment for worn or broken parts on a daily basis. Do not operate the equipment if you are uncertain about its condition.



### NEVER MODIFY THE EQUIPMENT

Do not modify the equipment unless the manufacturer provides written approval.



### KNOW WHERE AND HOW TO SHUT OFF THE EQUIPMENT IN CASE OF AN EMERGENCY



### PRESSURE RELIEF PROCEDURE

Always follow the pressure relief procedure in the equipment instruction manual.



### NOISE HAZARD

You may be injured by loud noise. Hearing protection may be required when using this equipment.



### STATIC CHARGE

Fluid may develop a static charge that must be dissipated through proper grounding of the equipment, objects to be sprayed and all other electrically conductive objects in the dispensing area. Improper grounding or sparks can cause a hazardous condition and result in fire, explosion or electric shock and other serious injury.



### FIRE AND EXPLOSION HAZARD

Never use 1,1,1-trichloroethane, methylene chloride, other halogenated hydrocarbon solvents or fluids containing such solvents in equipment with aluminum wetted parts. Such use could result in a serious chemical reaction, with the possibility of explosion. Consult your fluid suppliers to ensure that the fluids being used are compatible with aluminum parts.

**IT IS THE RESPONSIBILITY OF THE EMPLOYER TO PROVIDE THIS INFORMATION TO THE OPERATOR OF THE EQUIPMENT.**

**FOR FURTHER SAFETY INFORMATION REGARDING BINKS AND DEVILBISS EQUIPMENT,  
SEE THE GENERAL EQUIPMENT SAFETY BOOKLET (77-5300).**

**BINKS "TROPHY" SERIES TOUCH-UP SPRAY GUN**

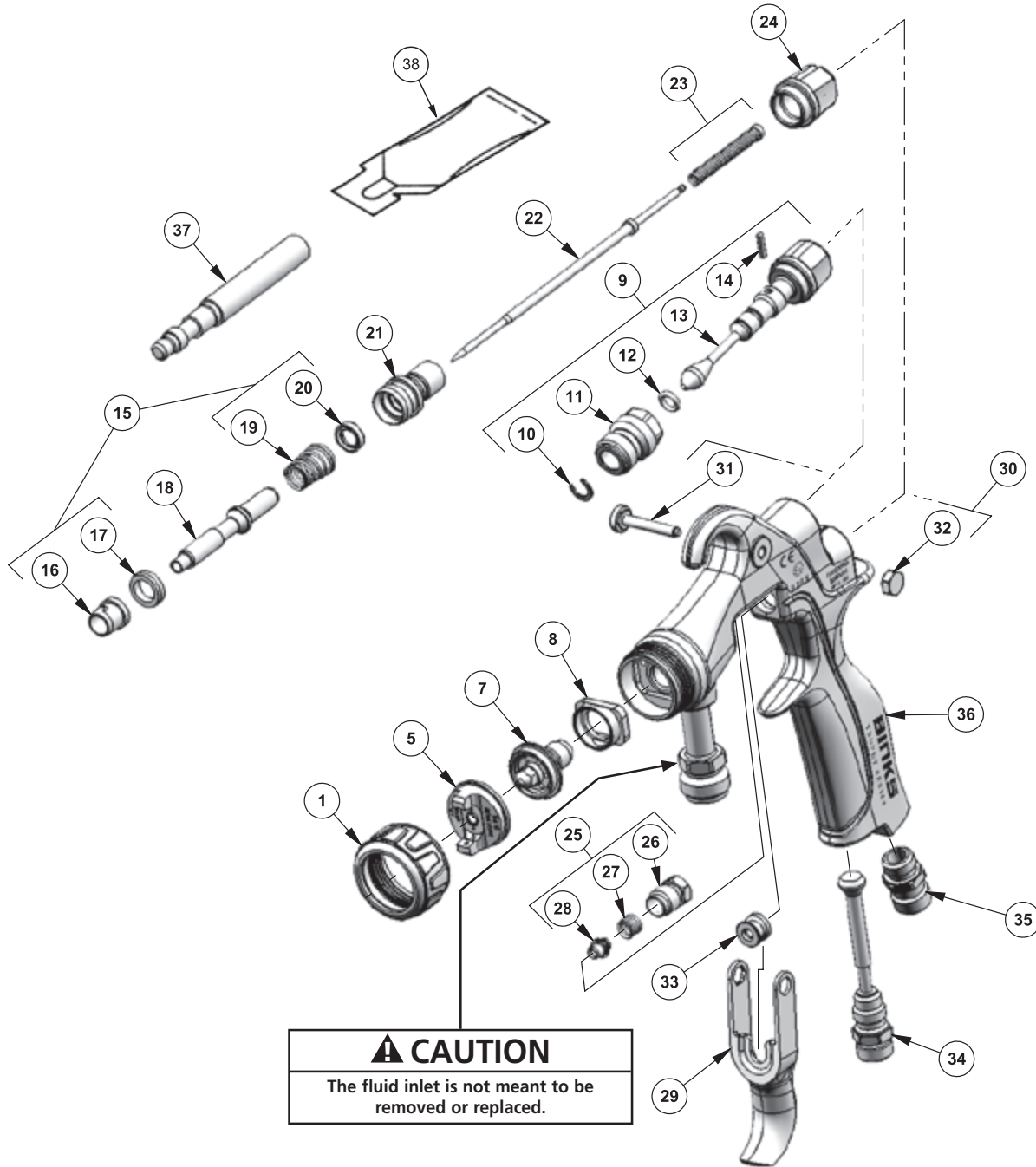

**CAUTION**  
The fluid inlet is not meant to be removed or replaced.

**SELECTION GUIDE FOR BINKS "TROPHY" SERIES TOUCH-UP SPRAY GUNS**

TYPE OF FLUID TO BE SPRAYED	COMPLETE GUN ASSEMBLY PART NUMBER	FLUID NOZZLE AND AIR CAP	SPRAY TECHNOLOGY
<b>VERY LIGHT/Reduced Flow</b>	1465-08HV-C1S	0.8 mm X C1	HVLP
<b>LIGHT/MEDIUM</b> 15 – 20 seconds, Zahn 2 Stains, varnishes, thin lacquers, automotive refinishing materials	1465-10LV-A1S	1.0 mm X A1	ROUND
	1465-10LV-B1S	1.0 mm X B1	LVMP
	1465-10HV-C1S	1.0 mm X C1	HVLP
	1465-10HV-C1P •	1.0 mm X C1	HVLP
	1465-14HV-C1P •	1.4 mm X C1	HVLP

TYPE OF FLUID TO BE SPRAYED	COMPLETE GUN ASSEMBLY PART NUMBER	FLUID NOZZLE AND AIR CAP	SPRAY TECHNOLOGY
<b>MEDIUM</b> 20 – 30 seconds, Zahn 2 General industrial coatings, Enamels, Epoxies, Fine grit ceramics	1465-12LV-B1S	1.2 mm X B1	LVMP
	1465-12HV-C1S	1.2 mm X C1	HVLP
<b>HEAVY</b> Greater than 30 seconds, Zahn 2 Low VOC coatings, Adhesives, Fine grit ceramics	1465-14LV-B1S	1.4 mm X B1	LVMP
	1465-14HV-C1S	1.4 mm X C1	HVLP

• Plastic Tip Needle Set-ups

**CHART 1: BINKS "TROPHY" SERIES TOUCH-UP SPRAY GUN PARTS LIST**

ITEM NO.	PART NUMBER	DESCRIPTION	QTY.	ITEM NO.	PART NUMBER	DESCRIPTION	QTY.
1	54-6211	AIR CAP RETAINING RING ASSEMBLY	1	23	54-6223-K	<input type="checkbox"/> SPRING/PAD ASSEMBLY	1
5	SEE CHARTS BELOW	AIR CAP	1	24	54-6111	KNOB – NEEDLE ADJUSTING	1
7	SEE CHARTS BELOW	FLUID NOZZLE	1	25	54-6130-K	<input type="checkbox"/> NEEDLE PACKING KIT	1
8	54-6215-K5	BAFFLE/SEPARATOR (KIT OF 5)	1	26	-----	<input checked="" type="checkbox"/> NUT – PACKING	1
9	54-6216	SIDE PORT VALVE ASSEMBLY	1	27	-----	<input checked="" type="checkbox"/> SPRING FOR PACKING	1
10	-----	+ Δ RETAINING CLIP	1	28	-----	<input checked="" type="checkbox"/> ▼ NEEDLE PACKING	1
11	-----	+ BODY BUSHING	1	29	54-6218	TRIGGER	1
12	-----	+ Δ O-RING	1	30	54-6228-K	TRIGGER SCREW NUT KIT	1
13	-----	+ SIDE PORT STEM	1	31	-----	○ TRIGGER SCREW	1
14	-----	+ Δ PIN	1	32	-----	○ TRIGGER NUT	1
15	54-6131-K	<input type="checkbox"/> AIR VALVE SERVICE KIT	1	33	54-3513	SPINDLE CAP	1
16	-----	• FRONT SEAL – AIR VALVE	1	34	JJ-42	AIR ADJUSTING VALVE ASSEMBLY	1
17	-----	• FRONT AIR VALVE SEAL	1	35	JJ-30	FITTING – AIR INLET	1
18	54-6220	<input type="checkbox"/> AIR VALVE SPINDLE	1	36	-----	GUN BODY WITH FLUID INLET	1
19	-----	• AIR VALVE SPRING	1	37	-----	TOOL – SEAL INSERTION	1
20	-----	• REAR SEAL – AIR VALVE	1	38	-----	GUNNER'S MATE (3 CC TUBE)	1
21	SN-66	HOUSING	1	TO CONVERT TO SIPHON FEED, PURCHASE CUP 81-384, SOLD SEPARATELY.			
22	47-6851	NEEDLE – STAINLESS STEEL (STD.)	1				
	47-6852	NEEDLE – PLASTIC TIP	1	+ PARTS INCLUDED IN 54-6216 ■ PARTS INCLUDED IN 54-6130-K ▼ ALSO AVAILABLE IN KIT OF 3: SN-2-K3 • PARTS INCLUDED IN 54-6131-K ○ PARTS INCLUDED IN 54-6228-K Δ GTI-428-K5 SIDE PORT REPAIR KIT <input type="checkbox"/> PARTS INCLUDED IN 54-6136			

**CHART 2: AIR CAP OPTIONS**

DESIGNATION	PRESSURE FEED = P SIPHON FEED = S	ATOMIZATION TECHNOLOGY	PART NUMBER
A1	P/S	Round Spray	46-10020
B1	P/S	LVMP	46-10010
C1	P/S	HVLP	46-10000

HVLP TEST KIT FOR C1 AIR CAP: 54-6226

**CHART 3: HVLP AIR PRESSURES AND FLOWS**

GUN INLET PRESSURE (PSI)	AIR CAP AIR FLOW (SCFM)	AIR CAP ATOMIZING PRESSURE (PSI)
5	2.5	2
10	4.0	4
15	5.1	7
21	6.4	10

GUN INLET PRESSURE IS MEASURED AT THE GUN INLET FITTING WITH THE GUN TRIGGERED.

**CHART 4: LVMP AIR PRESSURES AND FLOWS**

GUN INLET PRESSURE (PSI)	AIR CAP AIR FLOW (SCFM)
15	4.7
20	5.8
25	6.9
30	7.8

**CHART 5: HARDENED STAINLESS STEEL FLUID NOZZLE OPTIONS**

MATERIAL	PART NO. / ORIFICE
<b>VERY LIGHT / REDUCED FLOW</b>	45-12080 0.8mm (.030")
<b>LIGHT/MEDIUM</b> 15 – 20 seconds, Zahn 2 Stains, varnishes, thin lacquers, automotive refinishing materials	45-12100 1.0mm (.040")
<b>MEDIUM</b> 20 – 30 seconds, Zahn 2 General industrial coatings, enamels, epoxies, fine grit ceramics	45-12120 1.2mm (.047")
<b>HEAVY</b> Greater than 30 seconds, Zahn 2 Low VOC coatings, adhesives, fine grit ceramics	45-12140 1.4mm (.055")

## TYPES OF INSTALLATION

Air pressure for atomization is regulated at the extractor. The flow of the fluid is adjusted by the fluid valve control knob on gun, viscosity of paint and air pressure.

### PRESSURE CUP HOOKUP (Figure 1)

For fine finishing with limited spraying. Air pressure for atomization is regulated at extractor; fluid pressure at cup regulator. Pressure cup is also available less regulator.

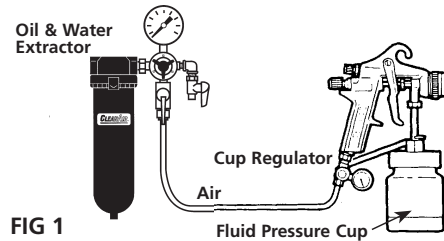

FIG 1

### PRESSURE TANK WITH 2 REGULATORS (Figure 2)

The pressure to the tank is regulated by the first regulator. The pressure for atomization is regulated by the second regulator.

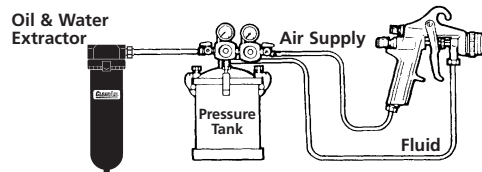

FIG 2

### PRESSURE CIRCULATING HOOKUP (Figure 3)

For heavy production spraying. Air pressure atomization regulated at extractor. Fluid pressure regulated at fluid regulator.

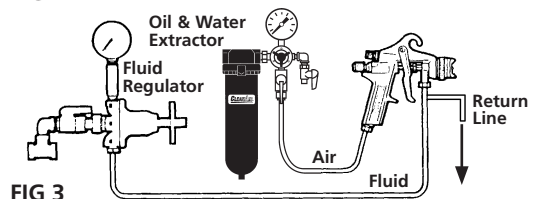

FIG 3

### SIPHON FEED HOOKUP (Figure 4)

Air pressure for atomization is regulated at extractor. The amount of fluid is adjusted by fluid control screw on gun, viscosity of paint, and air pressure.

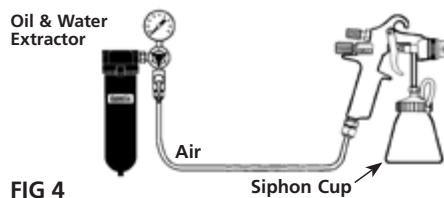

FIG 4

### FLUID PUMP HOOKUP (Figure 5)

For medium production spraying (single regulator). Air pressure for atomization is regulated at extractor, fluid pressure at pump regulator.

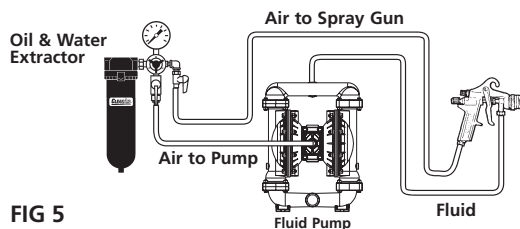

FIG 5

## AIR PRESSURE

Atomizing pressure must be set properly to allow for the drop in air pressure between the regulator and the spray gun.

**WITH 60 PSI APPLIED AT AIR SUPPLY**

5/16"

**RECOMMENDED**  
48 PSI at gun inlet

25 feet of 5/16" I.D. hose causes a drop of 12 PSI between the air supply and the gun. For this reason Binks recommends the use of 5/16" hose.

1/4"

**NOT RECOMMENDED**  
Only 34 PSI at gun inlet

25 feet of 1/4" I.D. hose causes a drop of 26 PSI between the air supply and the gun.

## An oil and water extractor is important.

Achieving a fine spray finish without the use of a good oil and water extractor is virtually impossible.

A regulator/extractor serves a double purpose. It eliminates blistering and spotting by keeping air free of oil and water, and it gives precise air pressure control at the gun.

Use DeVilbiss oil and water extractors and regulators. See your local distributor for models.

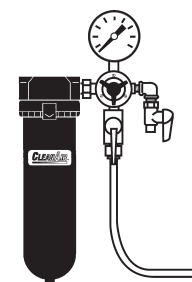

## INSTALLATION INSTRUCTIONS

For maximum transfer efficiency, do not use more pressure than is necessary to atomize the material being applied.

### NOTE

When using HVLP do not exceed inlet pressures listed on page 5.

1. Connect the gun to a clean, moisture and oil free air supply using a conductive hose of at least 5/16 in I.D.

### NOTE

Depending on hose length, larger I.D. hose may be required. Install an air gauge at the gun handle. See page 5 for operating pressures. Do not use more pressure than is necessary to atomize the material being applied. Excess pressure will create additional overspray and reduce transfer efficiency.

### NOTE

If quick connect couplings are required, use only high flow quick connects approved for HVLP use. Other types will not flow enough air for correct gun operation.

### NOTE

If an air adjusting valve is used at the gun inlet, use HAV-501 adjusting valve.

2. **SIPHON MODELS ONLY.** Purchase cup separately. Recommended cup: 8 oz. polyethylene cup (81-384). Use adapter (AD-404) supplied with the cup. Attach the cup lid assembly to the fluid inlet connector.
3. **PRESSURE FEED MODELS.** Connect the fluid supply hose to fluid inlet connector.

### NOTE

Before using the spray gun, flush it with solvent to ensure that the fluid passages are clean.

## OPERATION

### SIPHON MODELS

1. Mix coating material to manufacturer's instructions and strain material.
2. Fill the cup to no more than 3/4 inch from the top of the cup. DO NOT OVERFILL.
3. Attach to cup lid.

### ALL MODELS

4. Turn fluid adjusting knob (24) clockwise to prevent fluid needle movement.
5. Turn sideport control (9) counter clockwise to fully open.

6. Adjust inlet air pressure if required.
7. Turn fluid adjusting knob counter clockwise until first thread shows.
8. Test spray. If the finish is too dry, reduce airflow by reducing air inlet pressure.
9. If finish is too wet, reduce fluid flow by turning fluid adjusting knob (24) clockwise. If atomization is too coarse, increase inlet air pressure. If too fine, reduce inlet pressure.
10. The pattern size can be reduced by turning sideport control (9) clockwise.
11. Hold gun perpendicular to surface being sprayed. Arcing or tilting may result in uneven coating.
12. The recommended spray distance is 8 inches.
13. Spray edges first. Overlap each stroke a minimum of 75%. Move gun at a constant speed.
14. Always turn off air supply and relieve pressure when gun is not in use.

## PREVENTIVE MAINTENANCE AND CLEANING

To clean air cap and fluid nozzle, brush exterior with a stiff bristle brush. If necessary to clean cap holes, use a broom straw or toothpick if possible. If a wire or hard instrument is used, extreme care must be used to prevent scratching or burring of the holes which will cause a distorted spray pattern.

To clean fluid passages, remove excess material from gun, then flush with gun wash solution. Wipe the gun exterior with a dampened cloth. Never completely immerse in any solvent or cleaning solutions as this is detrimental to the lubricants and life of the spray gun.

### NOTE

When replacing the fluid nozzle (7) or fluid needle (22), replace both at the same time. Using worn parts can cause fluid leakage. See page 4. Also, replace the needle packing at this time. Torque the fluid nozzle to 170–180 inch-lbs. Do not over tighten.

### CAUTION

To prevent damage to fluid nozzle (7) or fluid needle (22), be sure to either 1) pull the trigger and hold while tightening or loosening the fluid nozzle, or 2) remove fluid adjusting knob (24) to relieve spring pressure against needle collar.

**SIPHON CUP.** Empty excess material and clean the cup. Make sure the vent hole in the lid is clear.



# REMOVAL AND INSTALLATION PROCEDURES

## NEEDLE AND VALVE DISASSEMBLY AND ASSEMBLY

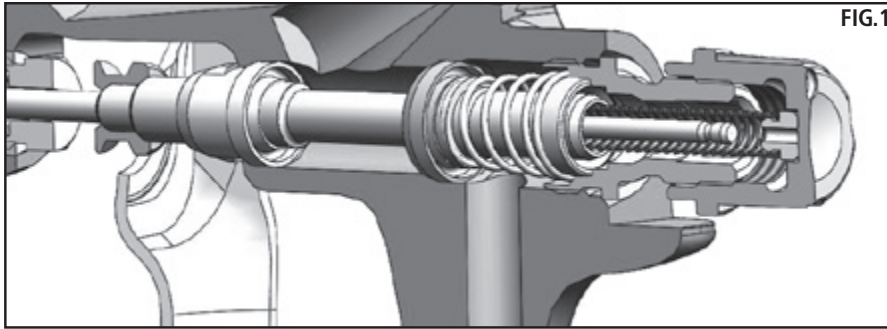

### DISASSEMBLY

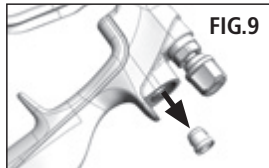
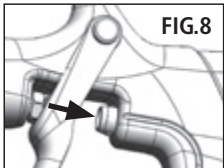
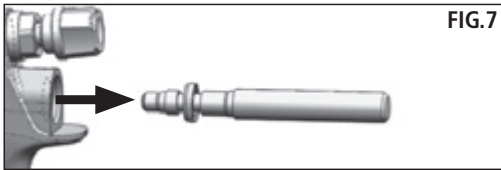
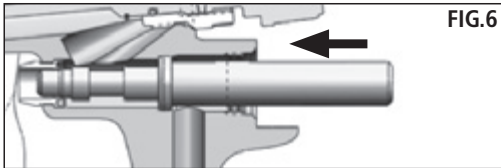
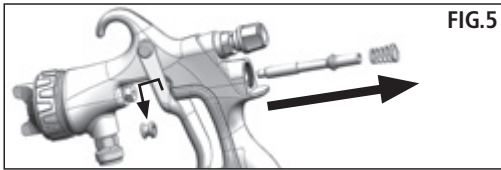
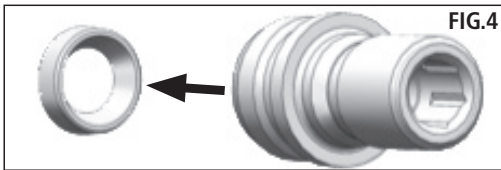
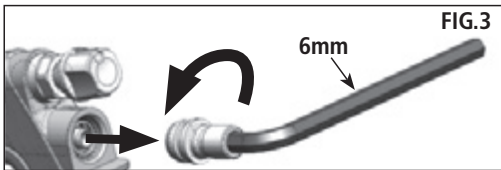
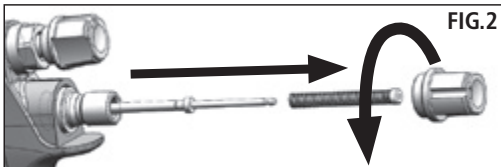

### ASSEMBLY

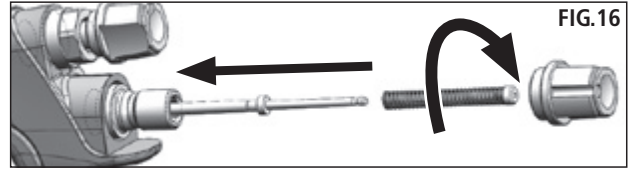
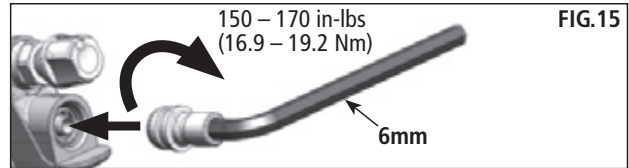
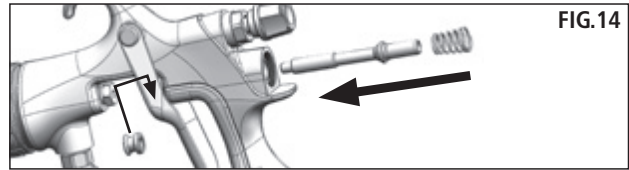
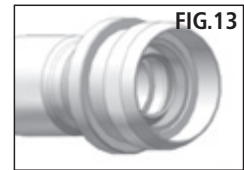
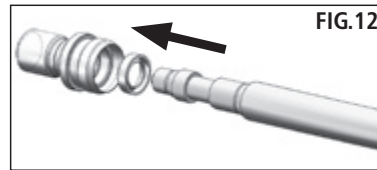
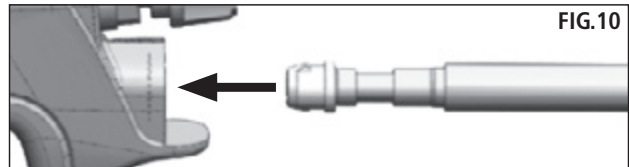



MAINTENANCE – FLUID NOZZLE AND BAFFLE REMOVAL AND INSTALLATION

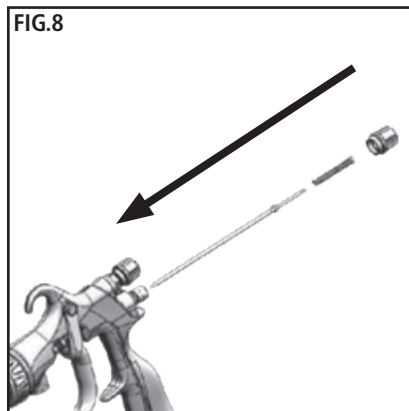
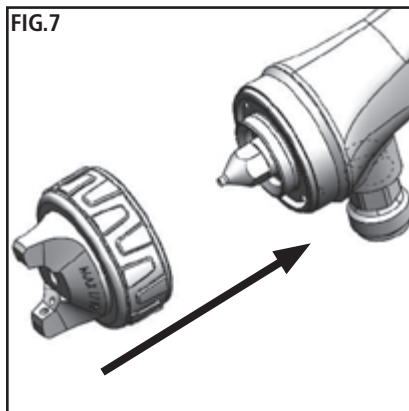
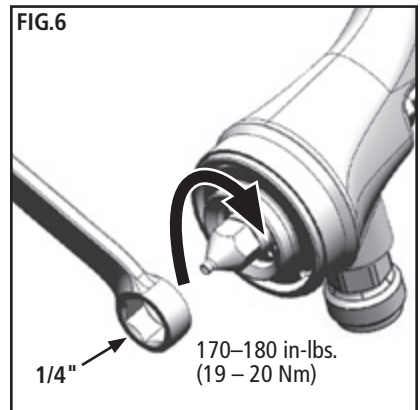
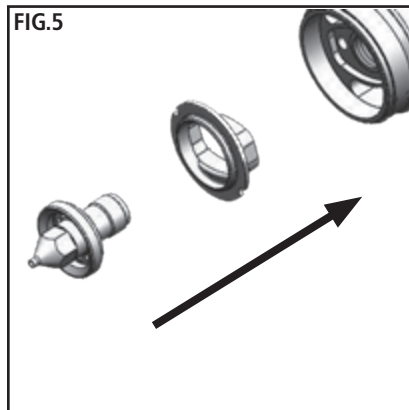
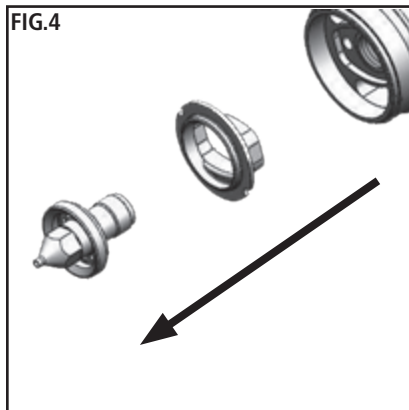
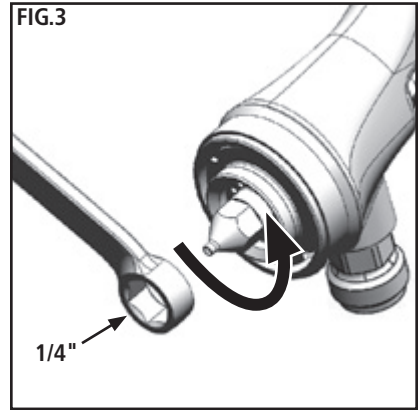
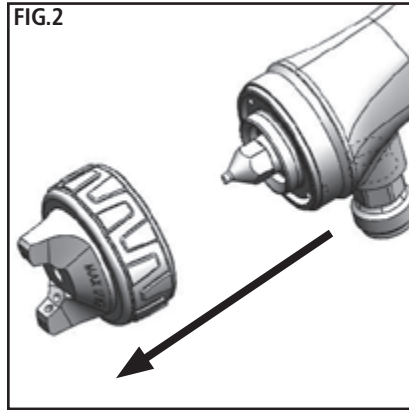
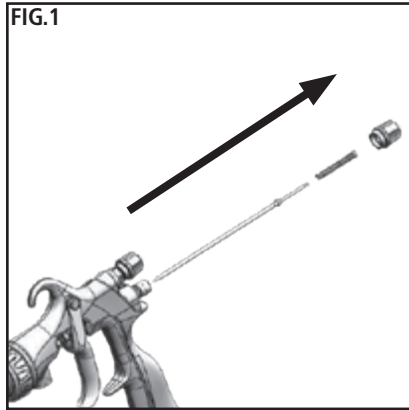



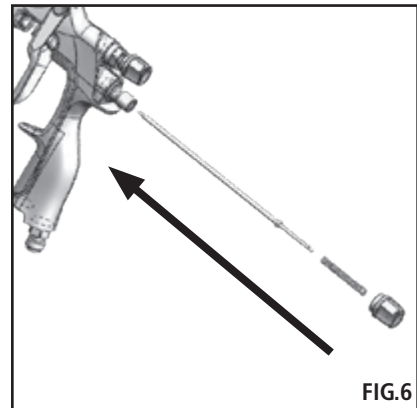
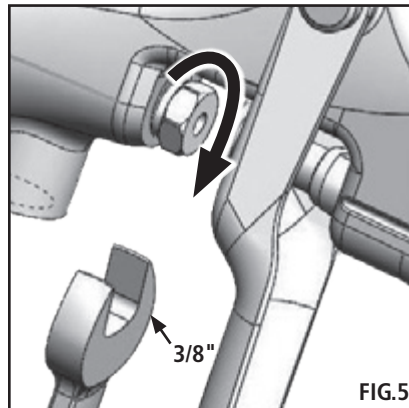
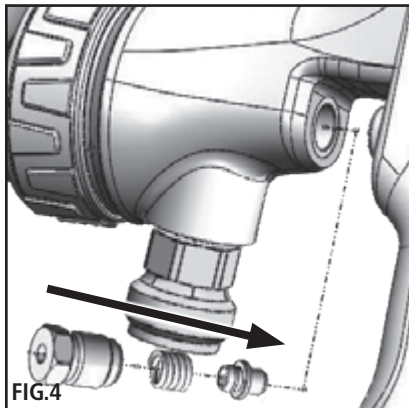
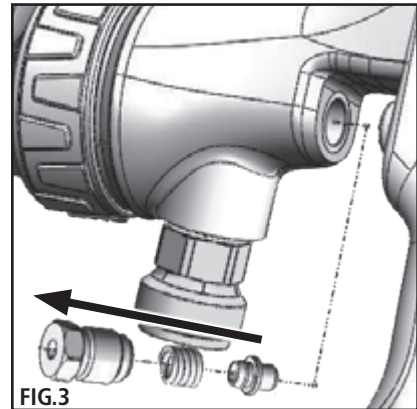
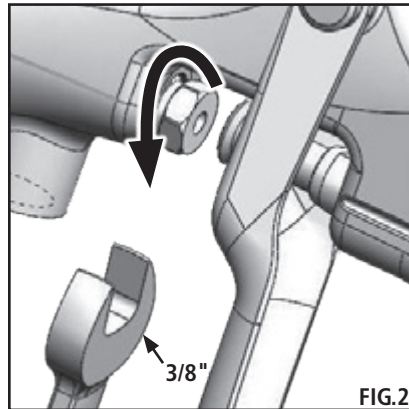
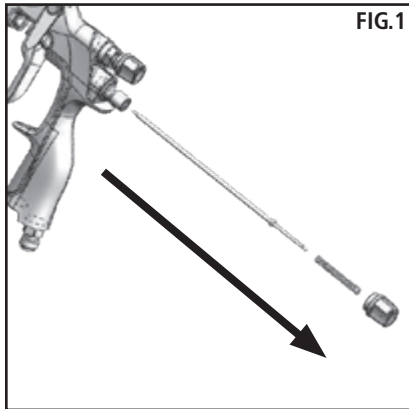

### MAINTENANCE – NEEDLE PACKING REMOVAL AND INSTALLATION

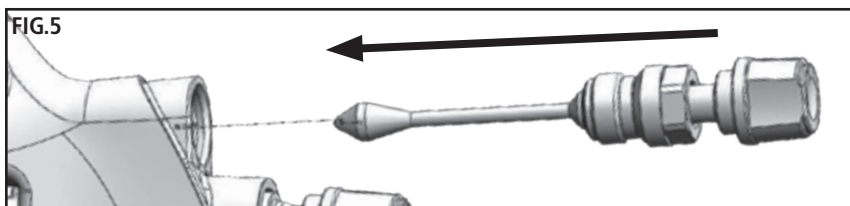
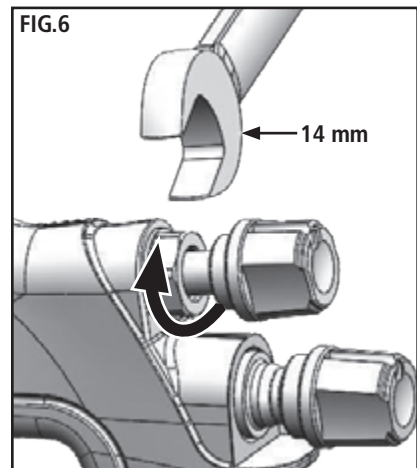
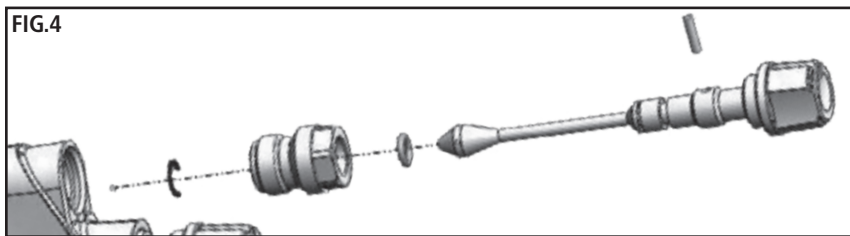
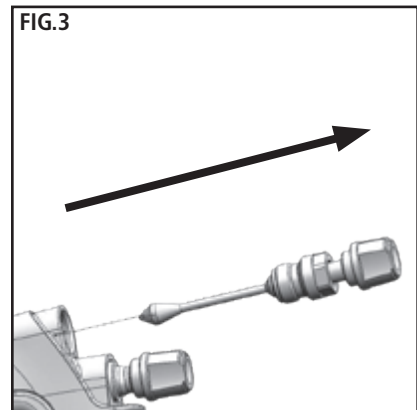
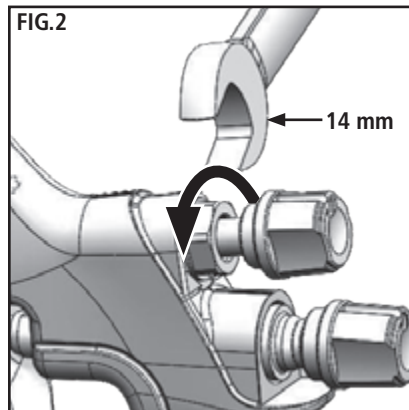
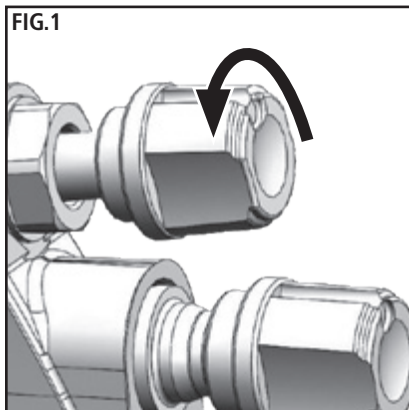

### MAINTENANCE – SIDEPORT REMOVAL AND INSTALLATION



## TROUBLESHOOTING

CONDITION	CAUSE	CORRECTION
<b>Heavy top or bottom pattern</b> 	Horn holes plugged. Obstruction on top or bottom of fluid tip. Cap and/or tip seat dirty.	Clean. Ream with non-metallic point. Clean. Clean.
<b>Heavy right or left side pattern</b> 	Left or right side horn holes plugged. Dirt on left or right side of fluid tip.	Clean. Ream with non-metallic point. Clean.
	Remedies for the top-heavy, bottom-heavy, right-heavy, and left-heavy patterns: 1. Determine if the obstruction is on the air cap or the fluid tip. Do this by making a test spray pattern. Then, rotate the cap one-half turn and spray another pattern. If the defect is inverted, obstruction is on the air cap. Clean the air cap as previously instructed. 2. If the defect is not inverted, it is on the fluid tip. Check for a fine burr on the edge of the fluid tip. Remove with #600 wet or dry sand paper. 3. Check for dried paint just inside the opening; remove by washing with solvent.	
<b>Heavy center pattern</b> 	Fluid flow too high for atomization air.  Material flow exceeds air cap's capacity. Spreader adjustment valve set too low. Atomizing pressure too low. Material too thick.	Balance air pressure and fluid flow. Increase spray pattern width with spreader adjustment valve.  Thin or lower fluid flow. Adjust. Increase pressure. Thin to proper consistency.
<b>Split spray pattern</b> 	Atomization air pressure too high. Fluid flow too low. Spreader adjusting valve set too high.	Reduce at transformer or gun. Increase fluid flow (increases gun handling speed). Adjust.
<b>Jerky or fluttering spray</b> 	*Loose or damaged fluid tip/seat. Material level too low. Container tipped too far. Obstruction in fluid passage. Dry or loose fluid needle packing nut.	Tighten or replace. Refill. Hold more upright. Backflush with solvent. Lubricate or tighten.
<b>Unable to get round spray</b>	Spreader adjustment screw not seating properly. Air cap retaining ring loose.	Clean or replace.  Tighten.
<b>Will not spray</b>	No air pressure at gun.  Fluid needle adjusting screw not open enough. Fluid too heavy for gravity feed.	Check air supply and air lines, blow out gun air passages. Open fluid needle adjusting screw. Thin material and/or change to larger tip size.
<b>Paint bubbles in cup</b>	Fluid tip not tight.	Tighten tip.
<b>Fluid leaking or dripping from cup lid</b>	Cup lid loose. Dirty threads on cup or lid. Cracked cup or lid.	Tighten lid. Clean. Replace cup and lid.

\*Most common problem.

## TROUBLESHOOTING

CONDITION	CAUSE	CORRECTION
<b>Starved spray pattern</b>	Inadequate material flow. Low atomization air pressure.	Back fluid adjusting screw out to first thread, or change to larger tip size. Increase air pressure and rebalance gun.
<b>Excessive overspray</b>	Too much atomization air pressure. Gun too far from work surface. Improper stroking (arcing, gun motion too fast).	Reduce pressure. Adjust to proper distance. Move at moderate pace, parallel to work surface.
<b>Excessive fog</b>	Too much or too fast-drying thinner. Too much atomization (air pressure.)	Remix properly. Reduce air pressure.
<b>Dry spray</b>	Air pressure too high. Gun tip too far from work surface. Gun motion too fast. Gun out of adjustment.	Reduce air pressure. Adjust to proper distance. Slow down. Adjust.
<b>Fluid leaking from packing nut</b>	Packing nut loose. Packing worn or dry.	Tighten, do not bind needle. Replace or lubricate.
<b>Fluid leaking or dripping from front of gun</b>	Packing nut too tight. Dry packing. Fluid tip or needle worn or damaged. Foreign matter in tip. Fluid needle spring broken. Wrong size needle or tip.	Adjust. Lubricate. Replace tip and needle. Clean. Replace. Replace.
<b>Fluid dripping or leaking from bottom of cup</b>	Cup loose on gun. Cup gasket worn or missing below cup. Cup threads dirty.	Tighten. Replace cup gasket. Clean.
<b>Runs and sags</b>	Too much material flow. Material too thin. Gun tilted on an angle, or gun motion too slow.	Adjust gun or reduce fluid flow. Mix properly or apply light coats. Hold gun at right angle to work and adapt to proper gun technique.
<b>Thin, sandy coarse finish drying before it flows out</b>	Gun too far from surface. Too much air pressure. Improper thinner being used.	Check distance. Normally approximately 8". Reduce air pressure and check spray pattern. Follow paint manufacturer's mixing instructions.
<b>Thick, dimpled finish "orange peel"</b>	Gun too close to surface. Too much material coarsely atomized. Air pressure too low. Improper thinner being used. Material not properly mixed. Surface rough, oily, dirty.	Check distance. Normally approximately 8". Follow paint manufacturer's mixing instructions. Increase air pressure or reduce fluid flow. Follow paint manufacturer's mixing instructions. Follow paint manufacturer's mixing instructions. Follow paint manufacturer's mixing instructions. Properly clean and prepare.

## ACCESSORIES

**HAF-507 Whirlwind™ In-Line Air Filter**  
(sold in multiples of 12)

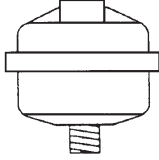

Removes water, oil, and debris from the air line.

**192212 Professional Spray Gun Cleaning Kit**



Contains six precision tools designed to effectively clean all DeVilbiss, Binks, Finishline and other brand spray guns.

**6-429 Binks Gunners Mate Lube**  
(Twenty 2 oz. bottles)



Compatible with all paint materials; contains no silicone or petroleum distillates to contaminate paint. SDS available upon request.

**HAV-500 OR HAV-501 Adjusting Valve**  
(HAV-501 SHOWN)

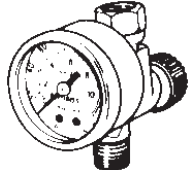

HAV-500 does not have pressure gauge. Use to control air usage at gun.

**Millennium 3000 Twin Cartridge Paint Spray Respirator**



NIOSH-Certified, for respiratory protection in atmospheres not immediately dangerous to life.

Small 40-141	Medium 40-128	Large 40-143
-----------------	------------------	-----------------

**Quick Connects for HVLP Guns (Air)**  
High Flow Type

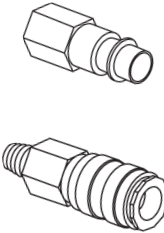

HC-4419 Stem  
1/4" NPT(F)  
Gun End

HC-4719 Coupler  
1/4" NPT(M)  
Hose End

**29-3100 Scrubs® Hand Cleaner Towels**



Scrubs® are a premoistened hand cleaner towel for painters, body men and mechanics that go where you go and no water is needed.

**Optional Siphon Cups**

**81-384**  
8 oz. polyethylene cup  
Features wide bottom for stability.

**81-540**  
8 oz. aluminum cup  
All metal construction  
Star wheel and yoke closure.

**AD-404 Adapter**  
1/4 NPS(m) x 3/8 NPS(f)

**DeKups® Accessories for siphon feed cups**

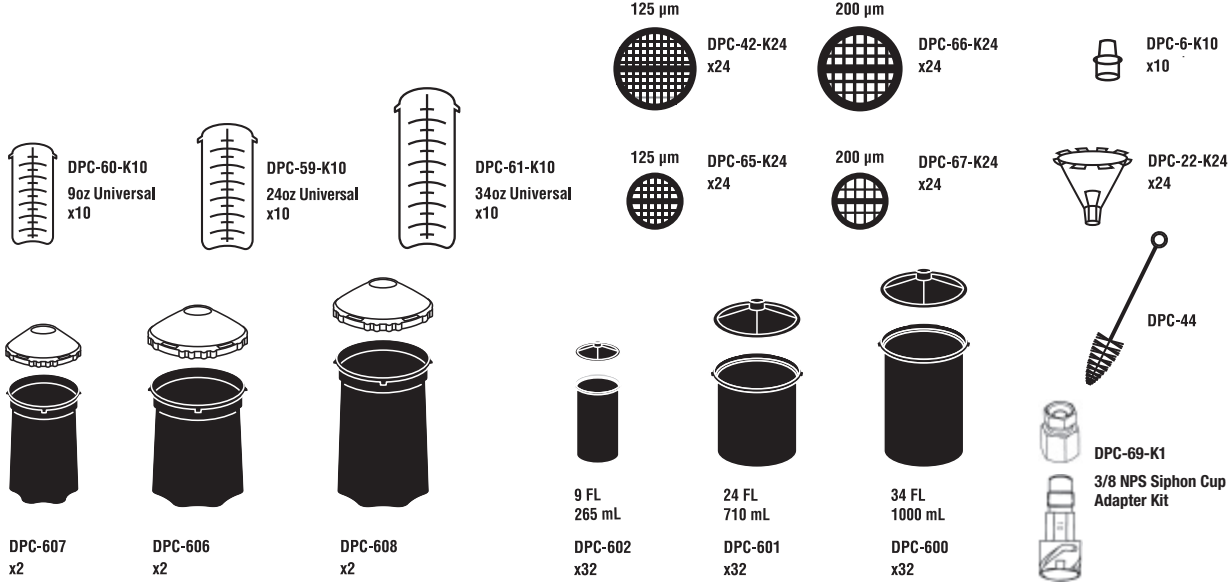

**125 µm**  
DPC-42-K24 x24

**200 µm**  
DPC-66-K24 x24

**DPC-6-K10** x10

**DPC-60-K10** 9oz Universal x10

**DPC-59-K10** 24oz Universal x10

**DPC-61-K10** 34oz Universal x10

**125 µm**  
DPC-65-K24 x24

**200 µm**  
DPC-67-K24 x24

**DPC-22-K24** x24

**DPC-44**

**DPC-69-K1** 3/8 NPS Siphon Cup Adapter Kit

**SHELLS**

DPC-607 x2

DPC-606 x2

DPC-608 x2

**LINERS**

9 FL 265 mL  
DPC-602 x32

24 FL 710 mL  
DPC-601 x32

34 FL 1000 mL  
DPC-600 x32

**54-6226 HVLP TEST CAP KIT**



HVLP AIR PRESSURES AND FLOWS		
GUN INLET PRESSURE (PSI)	AIR CAP AIR FLOW (SCFM)	AIR CAP ATOMIZING PRESSURE (PSI)
5	2.5	2
10	4.0	4
15	5.1	7
21	6.4	10

GUN INLET PRESSURE IS MEASURED AT THE GUN INLET FITTING WITH THE GUN TRIGGERED.







---

## WARRANTY POLICY

This product is covered by Carlisle Fluid Technologies' materials and workmanship limited warranty. The use of any parts or accessories, from a source other than Carlisle Fluid Technologies, will void all warranties. Failure to reasonably follow any maintenance guidance provided may invalidate any warranty.

For specific warranty information please contact Carlisle Fluid Technologies.

---

For technical assistance or to locate an authorized distributor, contact one of our international sales and customer support locations.

<b>Region</b>	<b>Industrial / Automotive</b>	<b>Automotive Refinishing</b>
Americas	Tel: 1-800-992-4657 Fax: 1-888-246-5732	Tel: 1-800-445-3988 Fax: 1-800-445-6643
Europe, Africa, Middle East, India	Tel: +44 (0)1202 571 111 Fax: +44 (0)1202 573 488	
China	Tel: +8621-3373 0108 Fax: +8621-3373 0308	
Japan	Tel: +81 45 785 6421 Fax: +81 45 785 6517	
Australia	Tel: +61 (0) 2 8525 7555 Fax: +61 (0) 2 8525 7575	

For the latest information about our products, visit [www.carlisleleft.com](http://www.carlisleleft.com)

---

Carlisle Fluid Technologies is a global leader in innovative finishing technologies. Carlisle Fluid Technologies reserves the right to modify equipment specifications without prior notice.

BGK™, Binks®, DeVilbiss®, Hosco®, MS®, and Ransburg® are all registered trademarks of Carlisle Fluid Technologies, Inc.

©2020 Carlisle Fluid Technologies, Inc.  
All rights reserved.

